

AQUOS 22/S

Componenti Struttura Esterna / External structure components / Bauteile Aussenkorpus / Composants structure externe / Componentes estructura externa

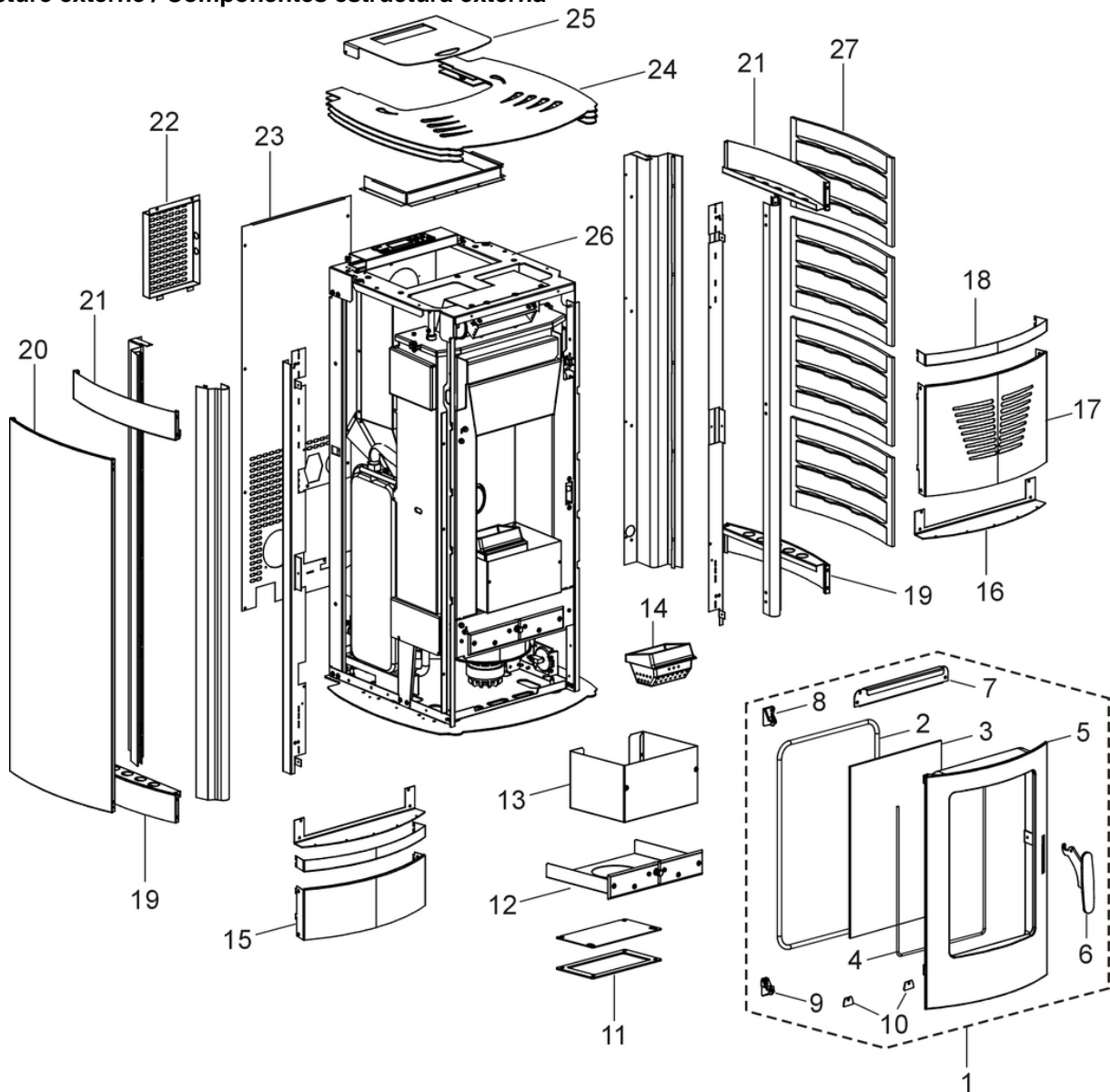

N°	Codice/Code	Descrizioni / Description / Beschreibung / Description / Description
1	4D24013177	Porta fuoco completa / Complete fire door / Komplette Feuertür / Porte foyer complète / Puerta hogar completa
2	4D18013034A	Guarnizione Tricotex D.6mm (5m) / Gasket Tricotex D.6mm (5m) / Dichtung Tricotex D.6mm (5m) / Joint Tricotex D.6mm (5m) / Junta Tricotex D.6mm (5m)
2	4D18013034B	Guarnizione Tricotex D.6mm (50m) / Gasket Tricotex D.6mm (50m) / Dichtung Tricotex D.6mm (50m) / Joint Tricotex D.6mm (50m) / Junta Tricotex D.6mm (50m)
3	4D17013022	Vetro ceramico 442,5X288X4 mm / Ceramic glass 442,5X288X4 mm / * / Vitreoceramique 442,5X288X4 mm / *
4	4D18013008A	Guarnizione 10x3 (5m) / Gasket 10x3 (5m) / Dichtung 10x3 (5m) / Joint 10x3 (5m) / Junta 10x3 (5m)
4	4D18013008B	Guarnizione 10x3 (50m) / Gasket 10x3 (50m) / Dichtung 10x3 (50m) / Joint 10x3 (50m) / Junta 10x3 (50m)
5	4D13013026	Telaio porta nero / Black door frame / * / Cadre porte noir / *
5	4D1301302602	Telaio porta grigio / Grey door frame / * / Cadre porte gris / *
6	4D12013139	Maniglia / Handle / * / Poignée / *
7	4D2401317702	Fermavetro superiore nero / Upper glass fastening bracket / * / Etrier de fixation vitrocéramique / *
8	4D12013136	Cerniera superiore / Upper hinge / Oberes Scharnier / Charnière supérieure / Bisagra superior
9	4D12013137	Cerniera inferiore / Lower hinge / Unteres Scharnier / Charnière inférieure / Bisagra inferior

10	4D2401317703	Fermavetro inferiore / Lower glass fastening brackets / Unteres Haltebügel für Scheibenbefestigung / Etrier inférieur de fixation de la vitre / Retendor inferior del cristal
11	41800900600	Guarnizione / Gasket / Dichtung / Joint / Junta
12	41401046631	Cassetto cenere inferiore / Lower ash drawer / Unteres Aschenkasten / Tiroir à cendres inférieur / Cajón ceniza inferior
13	4D2401315418	Cassetto cenere / Ash drawer / Aschenkasten / Tiroir à cendres / Cajón ceniza
14	4D13013001	Braciere / Grate / * / Brasero / *
15	4D2401315413	Frontale inferiore nero / Black lower front / * / Frontal inférieur noir / *
16	4D24013177016	Profilo / Profile / Profil / Profil / Perfil
17	4D2401315414	Frontale superiore nero / Black upper front / * / Frontal supérieur noir / *
18	4D2401315415	Profilo / Profile / Profil / Profil / Perfil
19	4D2401315416	Tamponazione laterale nera / Black lateral filling / * / Tampon latéral noir / *
19	4D2401315416	Tamponazione laterale nera / Black lateral filling / * / Tampon latéral noir / *
20	6913007	Rivestimento metallo Silver / Silver metal cladding / * / Habillage métal Silver / *
20	6913008	Rivestimento metallo Antracite / Charcoal metal cladding / * / Habillage métal Antracite / *
20	6913009	Rivestimento metallo Rosso / Red metal cladding / * / Habillage métal Rouge / *
20	6913010	Rivestimento metallo Avorio / Ivory metal cladding / * / Habillage métal Ivoire / *
21	4D2401315416	Tamponazione laterale nera / Black lateral filling / * / Tampon latéral noir / *
21	4D2401315416	Tamponazione laterale nera / Black lateral filling / * / Tampon latéral noir / *
22	4D2401315405	Coperchio scheda madre / Motherboard cover / Deckel Hauptplatine / Couvercle carte mère / Tapadera tarjeta madre
23	4D2401315404	Schiena esterna / External back / Rückwand / Dossieret extérieur / Parte trasera
24	4D2401315402	Top nero / Black top / * / Dessus noir / *
25	4D2401315401	Coperchio serbatoio nero / Pellet hopper black cover / * / Couvercle réservoir noir / *
26	41400907563	Supporto top / Top support / Deckelhaltebügel / Support du dessus / Soporte del top
27	4D12512031	Ceramica laterale rosso / Red side ceramic / * / Céramique latérale rouge / *
27	4D12512032	Ceramica laterale avorio / Ivory side ceramic / * / Céramique latérale ivoire / *
27	4D12512033	Ceramica laterale nero brillante / Sparkling black side ceramic / * / Céramique latérale noire brillante / *
27	4D12512034	Pietra laterale serpentino / Lateral soapstone / * / Pierre latérale serpentine / *
27	4D12514004025	Pietra laterale bianca / White lateral stone / * / Pierre latérale blanche / *

AQUOS 22/S

Componenti interni meccanici ed elettronici / Electronic and mechanic internal parts / Interne mechanische und elektronische Bauteile / Composants internes mécaniques et électroniques / Componentes internos electrónicos y mecánicos

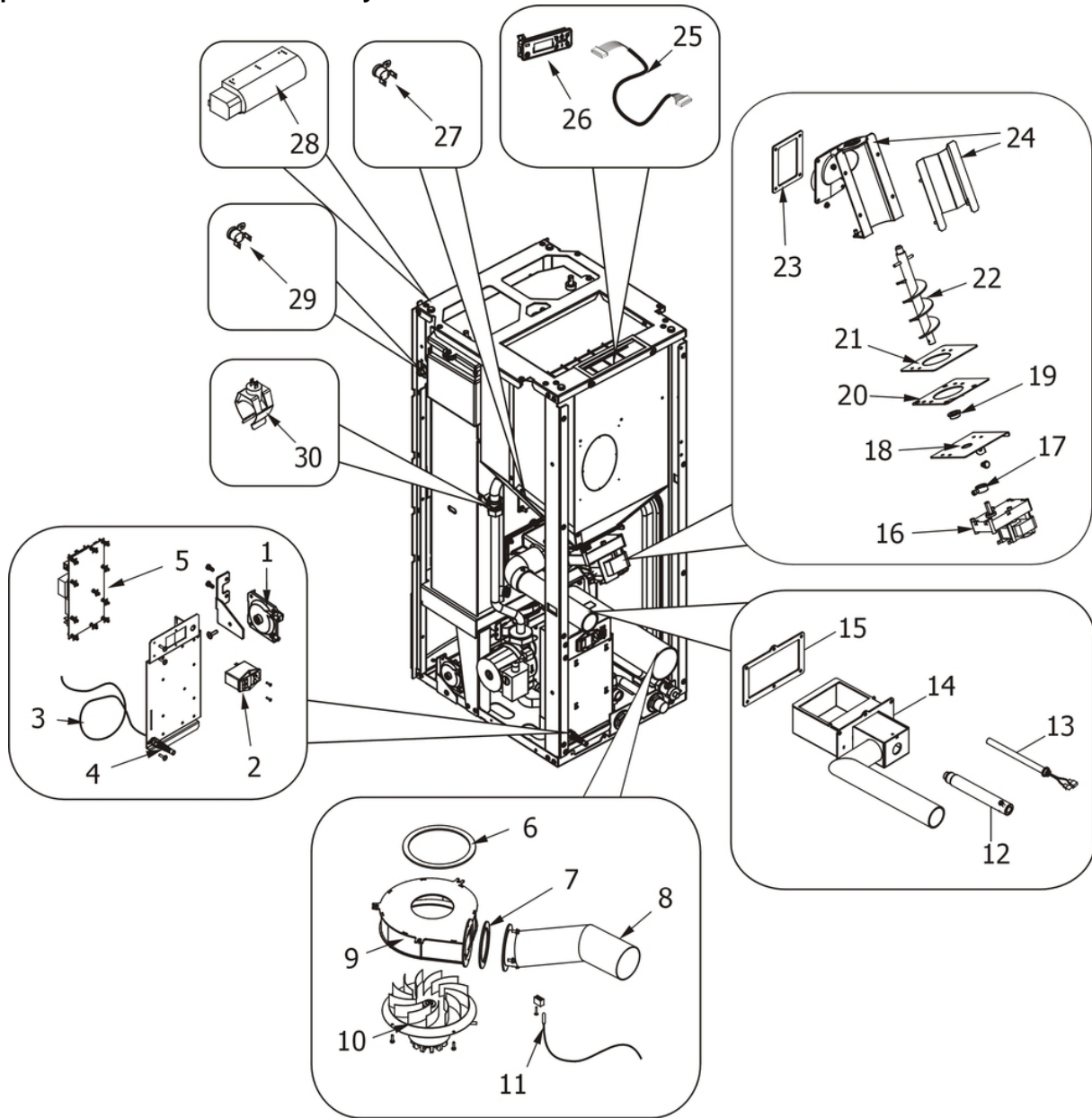

N°	Codice/Code	Descrizioni / Description / Beschreibung / Description / Descripción
1	414508040	Pressostato 1.2 mbar / Pressure switch 1.2 mbar / Druckwächter 1.2 mbar / Pressostat 1.2 mbar / Presostato 1.2 mbar
2	4160193	Pulsante accensione / On/Off button / Zündungstaste / Touche d'allumage / Botón encendido
3	4160386	Sonda temperatura ambiente/acqua / Room/Water temperature sensor / Raum- Wassertemperaturfühler / Sonde température ambiance/eau / Sonda temperatura ambiente/agua
4	414508038	Pressacavo / cable holder / Kabelklemme / presse-cable / presionacable
5	41451200500	Scheda madre completa / Complete mother board / Komplette Hauptplatine / Carte mère complete / Tarjeta madre completa
6	41800802801	Guarnizione adesiva voluta fumi / Adhesive gasket smoke volute / Haftendichtung Rauchvolute / Joint adhesive volute fumées / Junta adhesiva voluta humos
8	41601001460	Tubo uscita fumi / Smoke outlet pipe / Rohr Rauchabzug / Tuyau sortie fumées / Tubo salida humos
9	41401042942	Volute per ventilatore con encoder / Volute for fan with encoder / Volute für Gebläse mit Encoder / Volute pour ventilateur avec encoder / Voluta para ventilador con encoder

10	414508016	Ventilatore aspirazione fumi con encoder / Smoke exhaust fan WITH encoder / Rauchabsauggebläse MIT Encoder / Ventilateur aspiration fumées AVEC encoder / Ventilador aspiración humos con codificador
11	4160239	Sonda temperatura fumi / Smoke temperature sensor / Rauchtemperaturfühler / Sonde température fumées / Sonda temperatura humos
12	41200903900	Condotto candeletta / Sparkplug conduit / Zündkerzenkanal / Conduit bougie / Conducto bujía
13	41450905000	Candeletta accensione pellet / Pellet ignition sparkplug / Zündkerze Pelletzündung / Bougie d'allumage pellet / Bujía encendido pellet
14	41401069141V	Tasca braciere / Combustion pot container / Brenntopfkasten / Récipient braséro / Contenidor brasero
15	418008027	Guarnizione / Gasket / Dichtung / Joint / Junta
16	41450901600	Motoriduttore 3,3 rpm Merkle Korff / Reduction motor 3,3 rpm Merkle Korff / Getriebemotor 3,3 RPM MERKLE KORFF / Motoréducteur 3,3 RPM MERKLE KORFF / Motorreductor 3,3 rpm Merkle Korff
17	4120398	Connettore motoriduttore-coclea / Reduction motor-feed screw connector / Verbindung Getriebemotor-Schnecke / Connecteur motoréducteur-vis sans fin / Conector motorreductor-cóclea
18	41400944351	Base della coclea / Feed screw base / Untergestell der Förderschnecke / Base de la vis sans fin / Base de la cóclea
19	4120614	Boccola grafitata (2 pz) / Etched bush (2 pcs) / Graphitbuchse (2 Stck) / Bride graphitée (2 pcs) / Brida grafitada (2 pz)
20	41400903310	Flangia condotto coclea / Base of feed screw conduit / Untergestell Rohrleitung der Förderschnecke / Base du conduit de la vis sans fin / Base de conducto de la cóclea
21	4120615	Guarnizione base della coclea / Feed screw base gasket / Dichtung Untergestell der Förderschnecke / Joint pour la base de la vis sans fin / Junta base de la cóclea
22	41200901040	Coclea di caricamento pellet / Pellet feed screw / Pelletsförderschnecke / Vis sans fin pour chargement du pellet / Cóclea de carga pellet
23	418008029	Guarnizione / Gasket / Dichtung / Joint / Junta
24	41401077540V	Condotto della coclea / Conduit of feed screw / Rohrleitung der Förderschnecke / Conduit de la vis sans fin / Conducto de la cóclea
25	41451201900	Cavo Flat L 1,4 M / Flat cable L 1,4 M / Flat Kable L 1,4 M / Câble Flat L 1,4 M / Cable Flat L 1,4 M
26	41451303300	Pannello comandi / Control panel / * / Panneau de commande / *
27	412007004	Clickson 110°C / Clickson 110°C / Clickson 110°C / Clickson 110°C / Clickson 110°C
28	41451000300	Ventilatore scambiatore aria calda / Hot air exchanger fan / Wärmeluftgebläse / Ventilateur échangeur air chaud / Ventilador intercambiador aire caliente
29	41450901100	Clickson 95°C / Clickson 95°C / Clickson 95°C / Clickson 95°C / Clickson 95°C
30	41450901200	Sonda temperatura acqua / Water temperature sensor / Wassertemperaturfühler / Sonde température eau / Sonda temperatura agua

AQUOS 22/S

Componenti interni idraulici CON kit acqua sanitaria / Internal plumbing components WITH domestic water kit / Interne hydraulische Bauteile MIT Brauchwassersatz / Composants hydrauliques internes AVEC kit eau sanitaire / Componentes internos hidráulicos CON kit de agua sanitaria

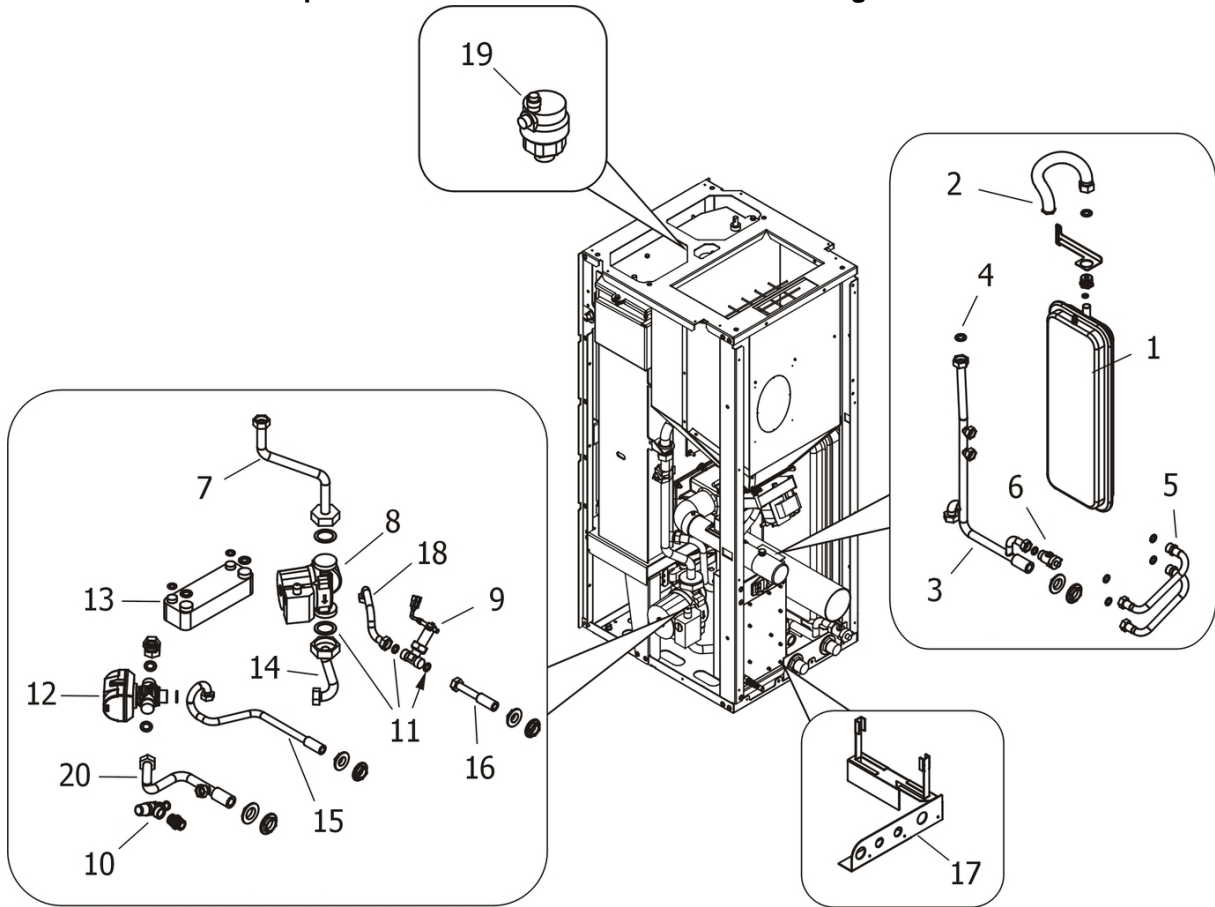

N°	Codice/Code	Descrizioni / Description / Beschreibung / Description / Description
1	4120775	Vaso espansione / Expansion vessel / Expansionsgefäß / Vase d'expansion / Vaso de expansión
2	4120781	Giunto estensibile inox 3/4" / 3/4" stainless steel flexible joint / Edelstahl Verbindungsschlauch 3/4" / Joint flexible inox 3/4" / junta flexible inox 3/4"
3	41501002300	Tubo di ritorno acqua in caldaia / Boiler water return tube / Wasserrücklaufrohr zum Kessel / Tuyau retour eau dans la chaudière / Tubo de regreso agua a la caldera
4	41207910	Kit guarnizioni impianto idraulico / Hydraulic system gasket kit / Dichtungsbausatz für Hydraulikanlage / Kit de joints pour l'installation hydraulique / Kit de juntas de la instalación de fontanería
5	41500901300	Tubo flessibile inox 1/2" / 1/2" stainless steel flexible tube / Edelstahlschlauch 1/2" / Tuyau flexible inox 1/2" / Tubo flexible inox 1/2"
6	4160351	Rubinetto scarico 1/2" con tappo / 1/2" drain valve with plug / Ablaufhahn 1/2" mit Stopfen / Robinet évacuation 1/2" avec bouchon / Grifo de desagüe 1/2" con tapón
7	41501002400	Tubo di mandata acqua da caldaia / Boiler water delivery tube / Vorlaufrohr Wasser vom Kessel / Tuyau de refoulement eau de la chaudière / Tubo de envío de agua de la caldera
8	4D1501205200	Pompa di circolazione / Circulation pump / * / Pompe de circulation / *
9	415008018	Flussostato / Flow switch / Strömungswächter / Fluxostat / Flujostato
10	4120778	Valvola di massima pressione (3 bar) / Maximum pressure valve (3 bar) / Hochdruckventil (3 Bar) / Soupape de pression maximale (3 bar) / Válvula de máxima presión (3 bar)
11	41207910	Kit guarnizioni impianto idraulico / Hydraulic system gasket kit / Dichtungsbausatz für Hydraulikanlage / Kit de joints pour l'installation hydraulique / Kit de juntas de la instalación de fontanería
12	41501001600	Valvola deviatrice a 3 vie / 3-way deviator valve / 3-Wegeumleitventil / Soupape de déviation à 3 voies / Válvula desviadora de 3 vías
13	415008017	Scambiatore a piastre / Plate heat exchanger / Plattenwärmetauscher / Échangeur à plaques / Intercambiador de placas
14	41501002000	Tubo di mandata acqua da caldaia / Boiler water delivery tube / Vorlaufrohr Wasser vom Kessel / Tuyau de refoulement eau de la chaudière / Tubo de envío de agua de la caldera

15	41501001900	Tubo di mandata acqua sanitaria / Domestic hot water delivery tube / Vorlaufrohr Warmwasser / Tuyau de refoulement eau sanitaire / Tubo de envío de agua caliente
16	41501002200	Tubo ingresso acqua sanitaria / Domestic water inlet tube / S�nitarwasser Eingangrohr / Tuyau d'entr�e eau sanitaire / Tubo de entrada agua sanitaria
17	41401069030	Staffa di supporto gruppo idraulico / Hydraulic group support bracket / Halteb�ugel der Hydraulischen Baugruppe / �trier support du group hydraulic / Zuncho de soporte del kit idraulico
18	41501205200	Pompa di circolazione acqua / Water circulation pump / Umw�lzpumpe / Pompe de circulation eau / Bomba circulaci�n agua
19	4120779	Valvola di sfiato / Vent valve / Entl�ftungsventil / Soupape de d�gagement / V�lvula respiradero
20	41501001800	Tubo di mandata / Water delivery tube / Vorlaufrohr Wasser / Tuyau de refoulement / Tubo de env�o de agua

AQUOS 22/S

Gruppo scambiatore / Exchanger group / Austausch Baugruppe / Groupe échangeur / Grupo intercambiador

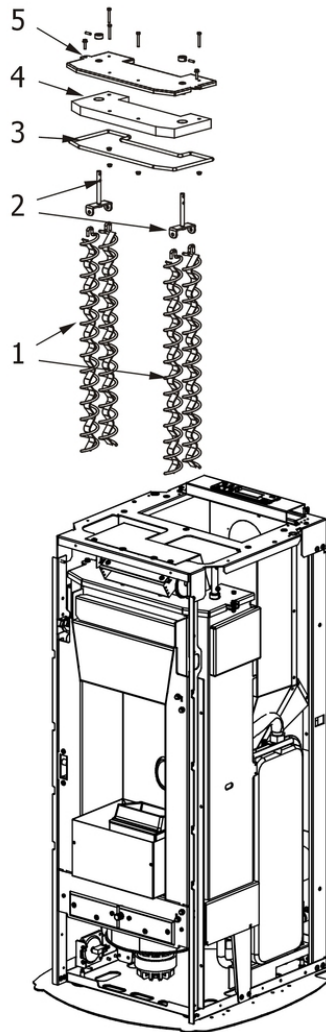

N°	Codice/Code	Descrizioni / Description / Beschreibung / Description / Descripción
1	41400914540	Eliche raschiatore (1 pz.) / Turbulator props (1 pc.) / Propeller des Schabers (1 Teil) / Hélices turbulateur (1 pz.) / Héliche rascador (1 pz.)
2	41400914740	Staffa sostegno raschiatore / Turbulator support bar / Haltebügel der Reinigungsspirale / étrier support turbulateur / Zuncho apoyo rascador
3	4120103A	Cordino fibroceramico Ø 10 mm (5 mt.) / Ceramic fibre cord Ø 10 mm (5 m) / Keramikfaserschnur Ø 10 mm (5 m) / Cordon en fibre céramique Ø 10 mm (5 m) / Junta a cuerda de fibra cerámica Ø 10 mm (5 m)
4	41150900100	Pannello calorite coperchio caldaia / Boiler cover calorite panel / Kesseldeckepaneel aus Calorite / Panneau en calorite couvercle chaudière / Panel en calorite tapa caldera
5	41400914840V	Coperchio scambiatore / Exchanger cover / Deckel des Austauschers / Couvercle Echangeur / Tapa intercambiador