

DOGE PLUS - DOGE3 PLUS

Componenti Struttura Esterna / External structure components / Bauteile Aussenkorpus / Composants structure externe / Componentes estructura externa

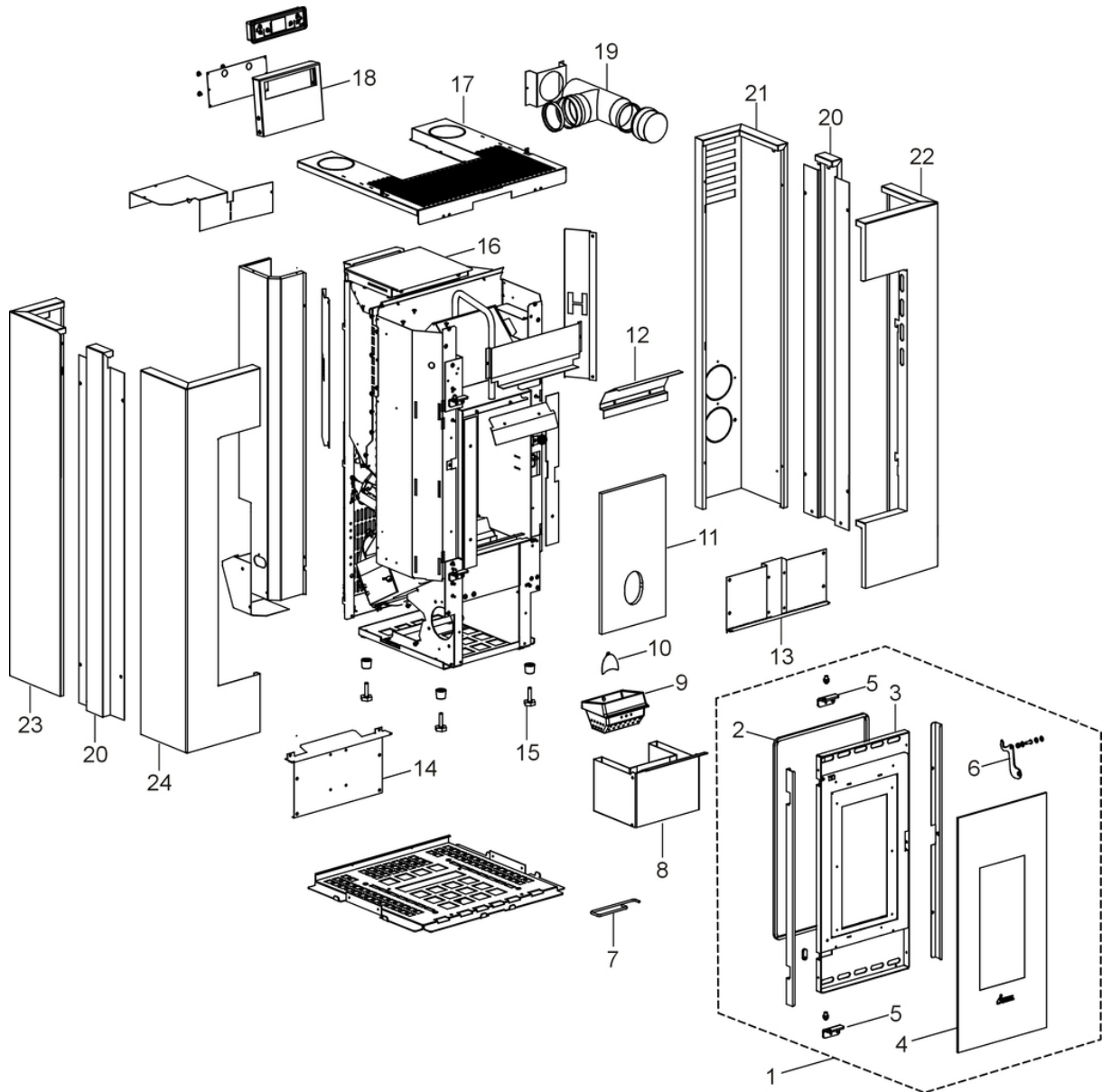

N°	Codice/Code	Descrizioni / Description / Beschreibung / Description / Description
1	4D245GP14004	Porta fuoco completa / Complete fire door / Komplette Feuertür / Porte foyer complète / Puerta hogar completa
2	4D18013021A	Guarnizione treccia nera D.10 - 5 M / Black twist gasket D.10 - 5 M / Dichtung D.10 - 5 M / Joint tresse noire D.10 - 5 M / Junta D.10 - 5 M
2	4D18013021B	Guarnizione treccia nera D.10 - 50 M / Black twist gasket D.10 - 50 M / Dichtung D.10 - 50 M / Joint tresse noire D.10 - 50 M / Junta D.10 - 50 M
3	4D24014064461	Telaio porta fuoco / Fire door frame / Feuertürrahmen / Cadre porte foyer / Armazón puerta hogar
4	4D170140040	Vetroceramico 308x668x4 mm / Glass 308x668x4 mm / Glasskeramikscheibe 308x668x4 mm / Vitrocéramique 308x668x4 mm / Cristal cerámico 308x668x4 mm
5	4D2401303720	Supporto porta nero / Black door support / Schwarzes Türhaltebügel / Support porte noir / Soporte puerta negro
5	4D2401303720	Supporto porta nero / Black door support / Schwarzes Türhaltebügel / Support porte noir / Soporte puerta negro
6	4D24014066161	Maniglia / Handle / Griff / Poignée / Tirador
6	4D24015841361	Kit decompressione camera di combustione / Pressure relief kit / Bausatz Überdruckablauf Brennkammer / Kit decompression chambre de combustion / Kit decompression cámara de combustión
7	4D12013060	Gancio "Mano fredda" / Hook "Cold hand" / Haken "Kalte Hand" / Crochet "Main froide" / Gancho "mano fría"

8	4D24014015461	Cassetto cenere / Ash drawer / Aschenkasten / Tiroir à cendres / Cajón ceniza
9	4D13013001	Braciere / Grate / Brennschale / Brasero / Brasero
10	4D2401303101	Deflettore pellet / Pellet deflector / Pellet Leitblech / Deflecteur pellet / Deflector pellet
11	4D115140020	Schiena in Calorite / Calorite back / Rückwand aus Calorite / Fond en Calorite / Parte trasera de Calorite
12	4D242140043	Supporto Vermiculite / Vermiculite support / Vermiculite Halterung / Support Vermiculite / Soporte Vermiculite
13	4D24014038361	Deflettore frontale nero / Black frontal deflector / Schwarze vordere Leitblech / Deflecteur frontal noir / Deflector frontal negro
14	4D24014037361	Frontalino inferiore / Frontal lower filler / Vordere untere Stopfung / Plaque frontale inférieure / Tapa frontal inferior
15	4D12013006	Piedini di appoggio (4 pz.) / Support feet (4 pcs.) / Einstellfüße (4 Stck.) / Vérins (4 pcs) / Pies de apoyo (4 pzs)
16	4D18013016	Guarnizione 155X190 mm / Gasket 155X190 mm / Dichtung 155x190 mm / Joint 155X190 mm / Junta 155X190 mm
16	4D24014020361	Coperchio serbatoio pellet / Pellet hopper cover / Deckel Pelletbehälter / Couvercle réservoir pellet / Tapadera depósito
17	4D24014034361	Top nero / Black top / Schwarze Topplatte / Dessus noir / Top negro
18	4D24014033363	Supporto pannello comandi / Display support / Display halterung / Support pour le panneau de commande / Soporte panel de mandos
19	4D160140070	Raccordo a "T" + Guarnizione / T-Union + Gasket / T-Stück + Dichtung / Raccord en "T" + joint / Tuvería en te + Junta
20	4D24014041363	Profilo / Profile / Profil / Profil / Perfil
20	4D24014041363	Profilo / Profile / Profil / Profil / Perfil
21	4D24014040440	Pannello posteriore DX Antracite / R. rear Charcoal side / Hintere R. Anthrazite Platte / Panneau postérieur D. Antracite / Placa posterior DCHA Antracita
21	4D24014040446	Pannello posteriore DX Silver HJT / R. rear Silver HJT side / Hintere R. Silver HJT Platte / Panneau postérieur D. Silver HJT / Placa posterior DCHA Silver HJT
21	4D24014040491	Pannello posteriore DX Rosso / R. rear Red side / Hintere R. Rot Platte / Panneau postérieur D. Rouge / Placa posterior DCHA Roja
21	4D24014040496	Pannello posteriore DX Bianco / R. rear White side / Hintere R. Weiß Platte / Panneau postérieur D. Blanc / Placa posterior DCHA Blanca
22	4D24014036440	Pannello anteriore DX Antracite / R. frontal Charcoal side / Vordere R. Anthrazite Platte / Panneau antérieur D. Antracite / Placa anterior DCHA Antracita
22	4D24014036446	Pannello anteriore DX Silver HJT / R. frontal Silver HJT side / Vordere R. Silver HJT Platte / Panneau antérieur D. Silver HJT / Placa anterior DCHA Silver HJT
22	4D24014036491	Pannello anteriore DX Rosso / R. frontal Red side / Vordere R. Rot Platte / Panneau antérieur D. Rouge / Placa anterior DCHA Roja
22	4D24014036496	Pannello anteriore DX Bianco / R. frontal White side / Vordere R. Weiße Platte / Panneau antérieur D. Blanc / Placa anterior DCHA Blanca
23	4D24014039440	Pannello posteriore SX Antracite / L. rear Charcoal side / Hintere L. Anthrazite Platte / Panneau postérieur G. Antracite / Placa posterior IZDA Antracita
23	4D24014039446	Pannello posteriore SX Silver HJT / L. rear Silver HJT side / Hintere L. Silver HJT Platte / Panneau postérieur G. Silver HJT / Placa posterior IZDA Silver HJT
23	4D24014039491	Pannello posteriore SX Rosso / L. rear Red side / Hintere L. Rot Platte / Panneau postérieur G. Rouge / Placa posterior IZDA Roja
23	4D24014039496	Pannello posteriore SX Bianco / L. rear White side / Hintere L. Weiß Platte / Panneau postérieur G. Blanc / Placa posterior IZDA Blanca
24	4D24014035440	Pannello anteriore SX Antracite / L. frontal Charcoal side / Vordere L. Anthrazite Platte / Panneau antérieur G. Antracite / Placa anterior IZDA Antracita
24	4D24014035446	Pannello anteriore SX Silver HJT / L. frontal Silver HJT side / Vordere L. Silver HJT Platte / Panneau antérieur G. Silver HJT / Placa anterior IZDA Silver HJT
24	4D24014035491	Pannello anteriore SX Rosso / L. frontal Red side / Vordere L. Rot Platte / Panneau antérieur G. Rouge / Placa anterior IZDA Roja
24	4D24014035496	Pannello anteriore SX Bianco / L. frontal White side / Vordere L. Weiß Platte / Panneau antérieur G. Blanc / Placa anterior IZDA Blanca

10	4D14513064B	Scheda madre / Motherboard / Hauptplatine / Carte mère / Tarjeta madre
11	4D2401302613	Supporto coclea / Feed screw support / Schnecke Halterung / Support de la vis-sans-fin / Soporte cóclea
12	4D140160030	Coclea di caricamento pellet / Pellet feed screw / Pelletsförderschnecke / Vis sans fin pour chargement du pellet / Cóclea de carga pellet
13	4D18013003	Guarnizione D.50 mm / Gasket D.50 mm / Dichtung D.50 mm / Joint D.50 mm / Junta D.50 mm
14	4D145159010	Motoriduttore 3,3 rpm / Reduction motor 3,3 rpm / Getriebemotor 3,3 rpm / Motoréducteur 3,3 rpm / Motorreductor 3,3 rpm
15	4D18013004	Guarnizione 100X108 mm / Gasket 100X108 mm / Dichtung 100x108 mm / Joint 100X108 mm / Junta 100X108 mm
16	4D14513002	Candeletta / Sparkplug / Zündkerze Pelletzündung / Bougie / Bujía encendido pellet
17	4D160140040	Tubo ingresso aria 60x2x210 mm / Air inlet pipe 60x2x210 mm / Lufteingangrohr 60x2x210 mm / Tuyau entrée air 60x2x210 mm / Tubo entrada aire D.80 L.200 mm
18	4D18013001	Guarnizione 130x80 mm / Gasket 130x80 mm / Dichtung 130x80 mm / Joint 130x80 mm / Junta 130x80 mm
18	4D18013001	Guarnizione 130x80 mm / Gasket 130x80 mm / Dichtung 130x80 mm / Joint 130x80 mm / Junta 130x80 mm
19	4D14513040	Raccordo D.80 mm / Connector D.80 mm / Anschlußrohr D.80 mm / Raccord D.80 mm / Racor D.80 mm
20	4D14513006	Termostato 60°C / Thermostat 60°C / Thermostat 60°C / Thermostat 60°C / Termostato 60°C
21	4D14513055	Telecomando / Remote control / Fernbedienung / Télécommande / Mando a distancia
22	4D14513032	Pannello comandi / Control panel / Bedienblende / Tableau de commande / Panel de mandos
23	4D14513007	Cavo flat scheda-pannello / Flat cable motherboard-control panel / Flat Kabel Hauptplatine-Bedienblende / Câble flat carte mère-panneau commande / Cable flat tarjeta madre-panel de mandos
24	4D14513009	Pressostato / Pressure switch / Druckwächter / Pressostat / Presostato
25	4D241140013	Carter posteriore / Back carter / Hinteres Blech / Protection arrière / Carter trasero