

DOGE PLUS BLACK

Componenti Struttura Esterna / External structure components / Bauteile Aussenkorpus / Composants structure externe / Componentes estructura externa

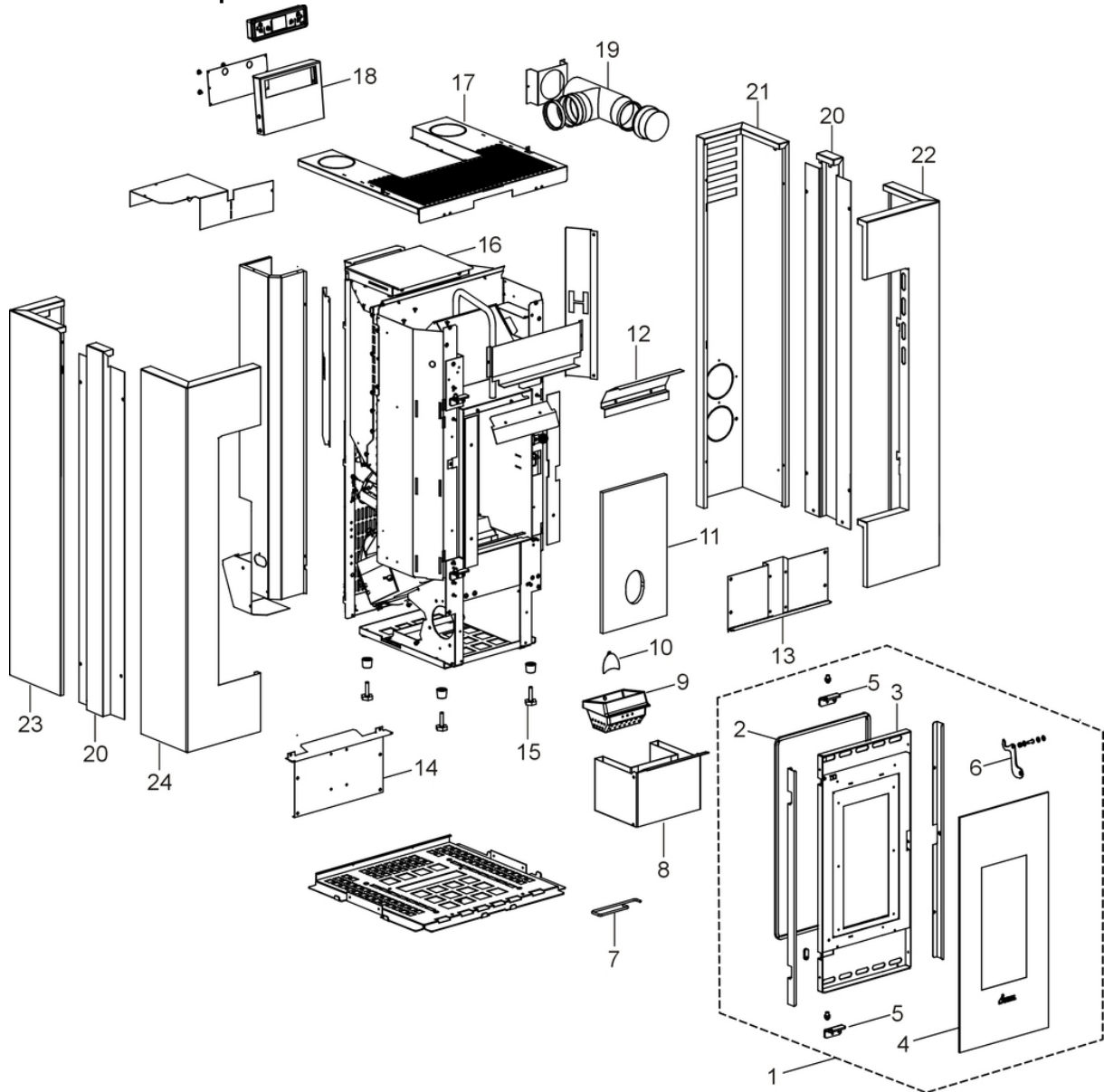

N°	Codice/Code	Descrizioni / Description / Beschreibung / Description / Description
1	4D245GP14004	Porta fuoco completa / Complete fire door / Komplette Feuertür / Porte foyer complète / Puerta hogar completa
2	4D18013021A	Guarnizione treccia nera D.10 - 5 M / Black twist gasket D.10 - 5 M / * / Joint tresse noire D.10 - 5 M / *
2	4D18013021B	Guarnizione treccia nera D.10 - 50 M / Black twist gasket D.10 - 50 M / * / Joint tresse noire D.10 - 50 M / *
3	4D24014064461	Telaio porta fuoco / Fire door frame / Feuertürrahmen / Cadre porte foyer / Armazón puerta hogar
4	4D170140040	Vetroceramico 308x668x4 mm / Glass 308x668x4 mm / Glasskeramikscheibe 308x668x4 mm / Vitrocéramique 308x668x4 mm / Cristal cerámico 308x668x4 mm
5	4D2401303720	Supporto porta nero / Black door support / * / Support porte noir / *
5	4D2401303720	Supporto porta nero / Black door support / * / Support porte noir / *
6	4D24014066161	Maniglia / Handle / Griff / Poignée / Tirador
7	4D12013060	Gancio "Mano fredda" / Hook "Cold hand" / * / Crochet "Main froide" / *
8	4D24014015461	Cassetto cenere / Ash drawer / Aschenkasten / Tiroir à cendres / Cajón ceniza
9	4D13013001	Braciere / Grate / * / Brasero / *
10	4D2401303101	Deflettore pellet / Pellet deflector / Pellet Leitblech / Deflecteur pellet / Deflector pellet
11	4D115140020	Schiena in Calorite / Calorite back / * / Fond en Calorite / *

12	4D242140043	Supporto Vermiculite / Vermiculite support / Vermiculite Halterung / Support Vermiculite / Soporte Vermiculite
13	4D24014038361	Deflettore frontale nero / Black frontal deflector / Schwarze vordere Leitblech / Deflecteur frontal noir / Deflector frontal negro
14	4D24014037361	Frontalino inferiore / Frontal lower filler / Vordere untere Stopfung / Plaque frontale inférieure / Tapa frontal inferior
15	4D12013006	Piedini (4 pz.) / Feet (4 pcs.) / * / Vérins (4 pcs) / *
16	4D24014020361	Coperchio serbatoio pellet / Pellet hopper cover / Deckel Pelletbehälter / Couvercle réservoir pellet / Tapadera depósito
17	4D24014034361	Top nero / Black top / Schwarze Topplatte / Dessus noir / Top negro
18	4D24014033363	Supporto pannello comandi / Display suport / Display halterung / Support pour le panneau de comande / Soporte panel de mandos
19	4D160140070	Raccordo a "T" + Guarnizione / T-Union + Gasket / T-Stück + Dichtung / Raccord en "T" + joint / Tubería en te + Junta
20	4D24014041363	Profilo / Profile / Profil / Profil / Perfil
20	4D24014041363	Profilo / Profile / Profil / Profil / Perfil
21	4D24014040440	Pannello posteriore DX Antracite / R. rear Charcoal side / Hintere R. Anthrazite Platte / Panneau postérieur D. Antracite / Placa posterior DCHA Antracita
21	4D24014040446	Pannello posteriore DX Silver HJT / R. rear Silver HJT side / Hintere R. Silver HJT Platte / Panneau postérieur D. Silver HJT / Placa posterior DCHA Silver HJT
21	4D24014040491	Pannello posteriore DX Rosso / R. rear Red side / Hintere R. Rot Platte / Panneau postérieur D. Rouge / Placa posterior DCHA Roja
21	4D24014040496	Pannello posteriore DX Bianco / R. rear White side / Hintere R. Weiß Platte / Panneau postérieur D. Blanc / Placa posterior DCHA Blanca
22	4D24014036440	Pannello anteriore DX Antracite / R. frontal Charcoal side / Vordere R. Anthrazite Platte / Panneau antérieur D. Antracite / Placa anterior DCHA Antracita
22	4D24014036446	Pannello anteriore DX Silver HJT / R. frontal Silver HJT side / Vordere R. Silver HJT Platte / Panneau antérieur D. Silver HJT / Placa anterior DCHA Silver HJT
22	4D24014036491	Pannello anteriore DX Rosso / R. frontal Red side / Vordere R. Rot Platte / Panneau antérieur D. Rouge / Placa anterior DCHA Roja
22	4D24014036496	Pannello anteriore DX Bianco / R. frontal White side / Vordere R. Weiße Platte / Panneau antérieur D. Blanc / Placa anterior DCHA Blanca
23	4D24014039440	Pannello posteriore SX Antracite / L. rear Charcoal side / Hintere L. Anthrazite Platte / Panneau postérieur G. Antracite / Placa posterior IZDA Antracita
23	4D24014039446	Pannello posteriore SX Silver HJT / L. rear Silver HJT side / Hintere L. Silver HJT Platte / Panneau postérieur G. Silver HJT / Placa posterior IZDA Silver HJT
23	4D24014039491	Pannello posteriore SX Rosso / L. rear Red side / Hintere L. Rot Platte / Panneau postérieur G. Rouge / Placa posterior IZDA Roja
23	4D24014039496	Pannello posteriore SX Bianco / L. rear White side / Hintere L. Weiß Platte / Panneau postérieur G. Blanc / Placa posterior IZDA Blanca
24	4D24014035440	Pannello anteriore SX Antracite / L. frontal Charcoal side / Vordere L. Anthrazite Platte / Panneau antérieur G. Antracite / Placa anterior IZDA Antracita
24	4D24014035446	Pannello anteriore SX Silver HJT / L. frontal Silver HJT side / Vordere L. Silver HJT Platte / Panneau antérieur G. Silver HJT / Placa anterior IZDA Silver HJT
24	4D24014035491	Pannello anteriore SX Rosso / L. frontal Red side / Vordere L. Rot Platte / Panneau antérieur G. Rouge / Placa anterior IZDA Roja
24	4D24014035496	Pannello anteriore SX Bianco / L. frontal White side / Vordere L. Weiß Platte / Panneau antérieur G. Blanc / Placa anterior IZDA Blanca

DOGE PLUS BLACK

Componenti interni meccanici ed elettronici / Electronic and mechanic internal parts / Interne mechanische und elektronische Bauteile / Composants internes mécaniques et électroniques / Componentes internos electrónicos y mecánicos

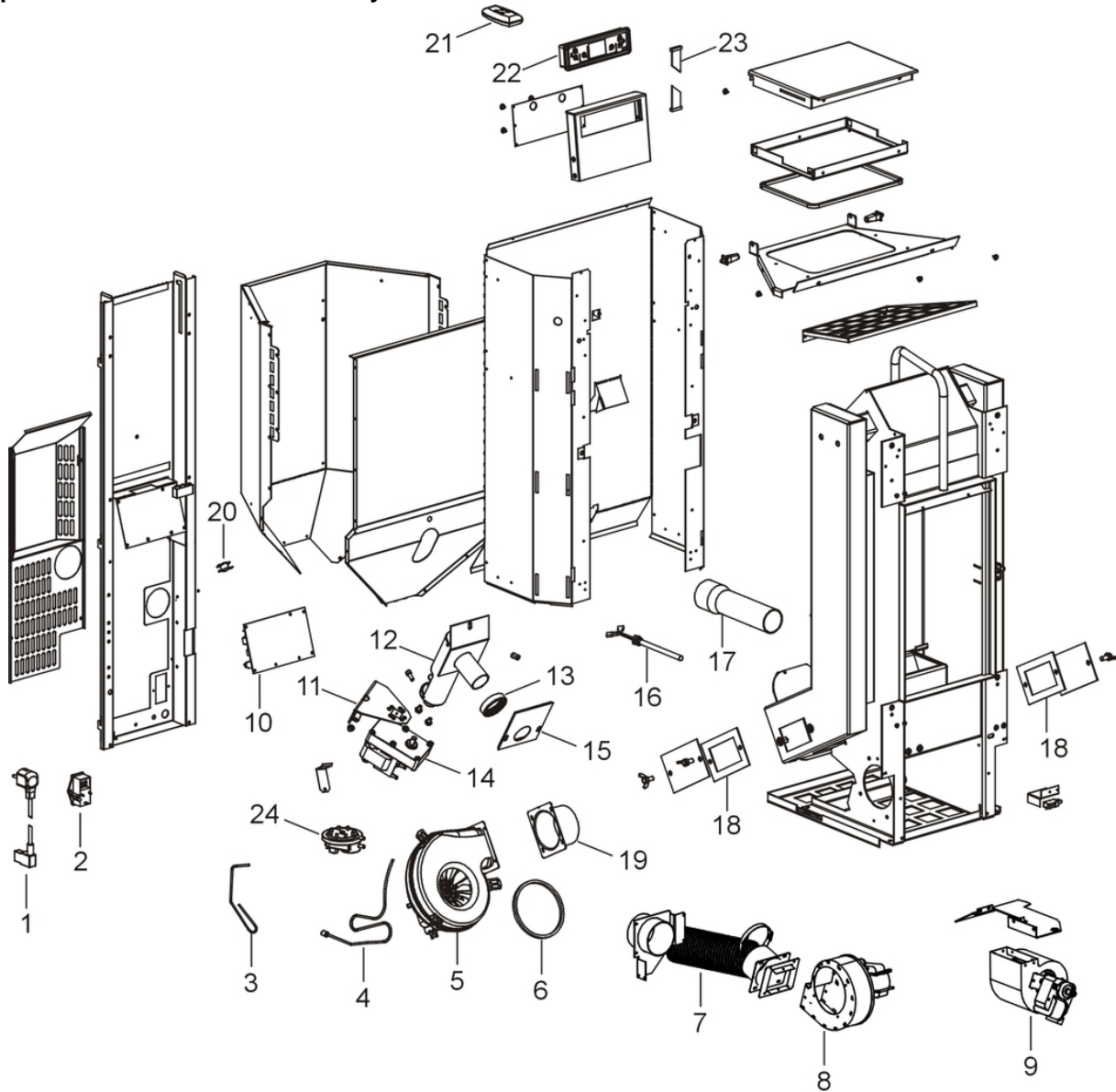

N°	Codice/Code	Descrizioni / Description / Beschreibung / Description / Description
1	4D14513041	Cavo alimentazione + Spina / Power source cable + Plug / * / Câble alimentation + Epine / *
2	4160193	Pulsante accensione / On/Off button / Zündungstaste / Touche d'allumage / Botón encendido
3	4D14513015	Sonda fumi / Smoke sensor / * / Sonde fumées / *
4	4D14513017	Sonda ambiente / Room temperature sensor / * / Sonde température ambience / *
5	41451003200	Ventilatore aspirazione fumi / Smoke exhaust fan / Rauchabsauggebläse / Ventilateur aspiration fumées / Ventilador aspiración de humos
5	4D145140150	Ventilatore fumi stagno / Tin smoke fan / Hermetisch Dichtrauchgebläse / Ventilateur fumées étanche / Ventilador humos hermético
6	4D18013024	Guarnizione / Gasket / * / Joint / *
7	4D160140060	Tubo flessibile alluminio D.80 L.200 mm / Flexible aluminium hose D.80 L.200 mm / Aluflexrohr D.80 L.200 mm / Tuyau flexible en aluminium D.80 L.200 mm / Tubo flexible en aluminio D.80 L.200 mm
8	4D145140010	Ventilatore aria / Air fan / * / Ventilateur air / *
9	4D14513054	Ventilatore aria / Air fan / * / Ventilateur air / *
10	4D14513064	Scheda madre / Motherboard / * / Carte mère / *

11	4D2401302613	Supporto coclea / Feed screw support / Schnecke Halterung / Support de la vis-sans-fin / Soporte cóclea
12	4D12013057	Assieme coclea - Versione corta con albero femmina / Auger set - Short version with female shaft / * / Groupe vis sans fin - Version courte avec arbre femelle / *
13	4D18013003	Guarnizione D.50 mm / Gasket D.50 mm / * / Joint D.50 mm / *
14	41450901600	Motoriduttore 3,3 rpm Merkle Korff / Reduction motor 3,3 rpm Merkle Korff / Getriebemotor 3,3 RPM MERKLE KORFF / Motoréducteur 3,3 RPM MERKLE KORFF / Motorreductor 3,3 rpm Merkle Korff
15	4D18013004	Guarnizione 100X108 mm / Gasket 100X108 mm / * / Joint 100X108 mm / *
16	4D14513002	Candeletta / Sparkplug / * / Bougie / *
17	4D160140040	Tubo ingresso aria 60x2x210 mm / Air inlet pipe 60x2x210 mm / Lufteingangsrohr 60x2x210 mm / Tuyau entrée air 60x2x210 mm / Tubo entrada aire D.80 L.200 mm
18	4D18013001	Guarnizione 130x80 mm / Gasket 130x80 mm / * / Joint 130x80 mm / *
18	4D18013001	Guarnizione 130x80 mm / Gasket 130x80 mm / * / Joint 130x80 mm / *
19	4D14513040	Raccordo D.80 mm / Connector D.80 mm / Anschlußrohr D.80 mm / Raccord D.80 mm / Racor D.80 mm
19	4D145140150	Ventilatore fumi stagno / Tin smoke fan / Hermetisch Dichtrauchgebläse / Ventilateur fumées étanche / Ventilador humos hermético
20	4D14513006	Termostato 60°C / Thermostat 60°C / * / Thermostat 60°C / *
21	4D14513055	Telecomando / Remote control / * / Télécommande / *
22	4D14513032	Pannello comandi / Control panel / * / Tableau de commande / *
23	4D14513007	Cavo flat scheda-pannello / Flat cable motherboard-control panel / * / Câble flat carte mère-panneau commande / *
24	4D14513009	Pressostato / Pressure switch / * / Pressostat / *