

IBIS 11 KW

Componenti Struttura Esterna / External structure components / Bauteile Aussenkorpus / Composants structure externe / Componentes estructura externa

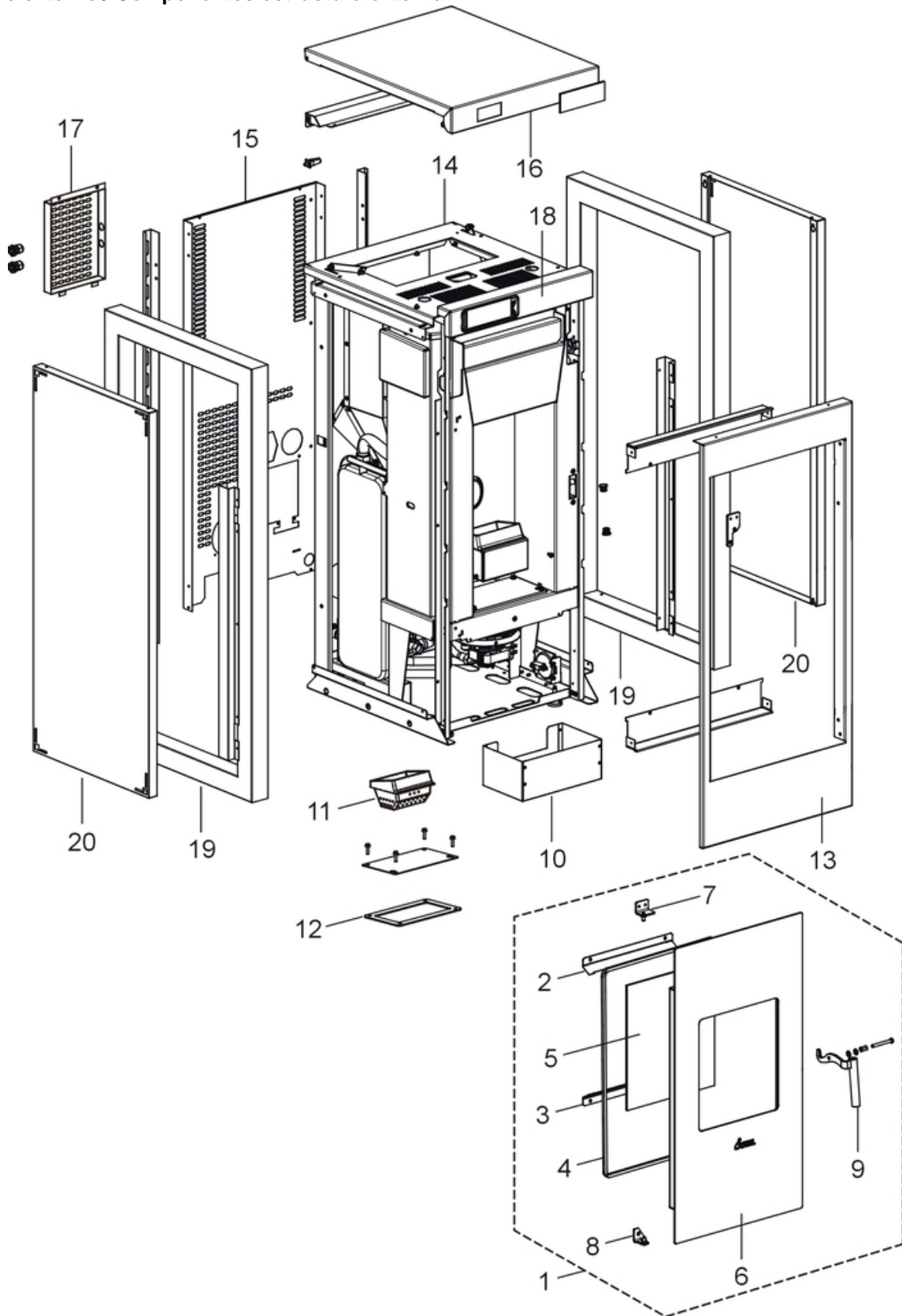

N°	Codice/Code	Descrizioni / Description / Beschreibung / Description / Descripcion
1	4D245GP14008	Porta fuoco completa / Complete fire door / Komplette Feuertür / Porte foyer complète / Puerta hogar completa
2	4D242146013	Fermavetro superiore/inferiore / Upper/Lower pyroceram fastening bracket / Oberes/Unteres Befestigungsbügel Glaskeramik / Étrier supérieure/inférieure de fixation vitrocéramique / Abrazadera superior/inferior de fijación vidrio cerámico
3	4D242146013	Fermavetro superiore/inferiore / Upper/Lower pyroceram fastening bracket / Oberes/Unteres Befestigungsbügel Glaskeramik / Étrier supérieure/inférieure de fixation vitrocéramique / Abrazadera superior/inferior de fijación vidrio cerámico
4	4D180146010	Guarnizione / Gasket / * / Joint / *
5	4D17013029	Vetroceramico 257x299x4 mm / Vitrocéramique 257x299x4 mm / Glasskeramikscheibe 257x299x4 mm / Glass 257x299x4 mm / Cristal cerámico 257x299x4 mm
6	4D24014611461	Telaio porta fuoco / Fire door frame / Feuerrahmen / Cadre porte foyer / Armazón puerta hogar
7	4D24014601361	Supporto superiore della porta / Upper door support / Oberes Türhaltebügel / Support supérieur de la porte / Soporte superior de la puerta
8	4D24014602361	Supporto inferiore della porta / Lower door support / Unteres Türhaltebügel / Support inférieur de la porte / Soporte inferior de la puerta
9	4D12013031	Maniglia / Handle / * / Poignée / *
10	4D2401315418	Cassetto cenere / Ash drawer / Aschenkasten / Tiroir à cendres / Cajón ceniza
11	413008003	Braciere completo in ghisa / cast iron complete grate / Kompletter Brennerkopf aus Gusseisen / Brasero complet en fonte / Brasero completo de arrabio
12	41800900600	Guarnizione / Gasket / Dichtung / Joint / Junta
13	4D24014621361	Telaio frontale / Frontal frame / Vorderes Rahmen / Cadre frontal / Armazón frontal
14	41400929830V	Supporto top / Top support / Deckelhaltebügel / Support du dessus / Soporte top
15	4D241146043	Schiena esterna / External back / Rückwand / Dossieret extérieur / Parte trasera
16	4D24014623363	Coperchio serbatoio pellet / Pellet hopper cover / Deckel Pelletbehälter / Couvercle réservoir pellet / Tapadera depósito
17	4D2401315405	Coperchio scheda madre / Motherboard cover / Deckel Hauptplatine / Couvercle carte mère / Tapadera tarjeta madre
18	4D24014622363	Pannello frontale nero / Black frontal panel / Vorderes schwarze Paneel / Panneau antérieur noir / Panel frontal negro
19	6914002	Rivestimento completo Rosso / Complete Red cladding / Komplette Verkleidung Rot / Habillage complète Rouge / Revestimiento completo Rojo
19	6914002	Rivestimento completo Rosso / Complete Red cladding / Komplette Verkleidung Rot / Habillage complète Rouge / Revestimiento completo Rojo
19	6914003	Rivestimento completo Bianco / Complete White cladding / Komplette Verkleidung Weiß / Habillage complète Blanc / Revestimiento completo Blanco
19	6914003	Rivestimento completo Bianco / Complete White cladding / Komplette Verkleidung Weiß / Habillage complète Blanc / Revestimiento completo Blanco
19	6914004	Rivestimento completo Cromo / Complete Chrome cladding / Komplette Verkleidung Chrom / Habillage complète Chrome / Revestimiento completo Cromo
19	6914004	Rivestimento completo Cromo / Complete Chrome cladding / Komplette Verkleidung Chrom / Habillage complète Chrome / Revestimiento completo Cromo
20	4D24014631363	Fianco nero / Black side / Schwarze Seite / Côté noir / Lateral negro
20	4D24014631363	Fianco nero / Black side / Schwarze Seite / Côté noir / Lateral negro

IBIS 11 KW

Componenti interni meccanici ed elettronici / Electronic and mechanic internal parts / Interne mechanische und elektronische Bauteile / Composants internes mécaniques et électroniques / Componentes internos electrónicos y mecánicos

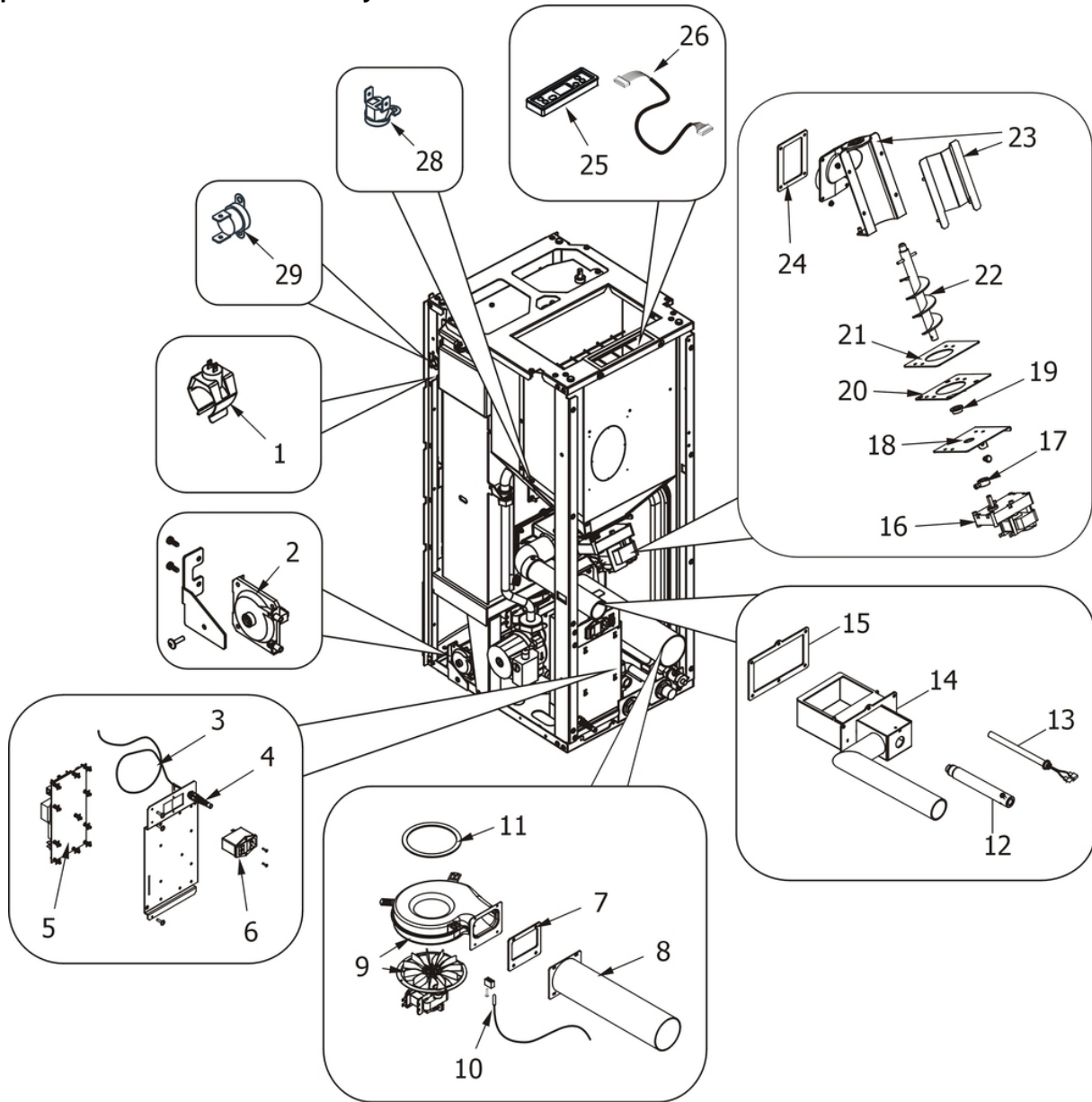

N°	Codice/Code	Descrizioni / Description / Beschreibung / Description / Descripción
1	41450901200	Sonda temperatura acqua / Water temperature sensor / Wassertemperaturfühler / Sonde température eau / Sonda temperatura agua
2	4160482	* / * / * / * / *
3	4160386	Sonda temperatura ambiente/acqua / Room/Water temperature sensor / Raum- Wassertemperaturfühler / Sonde température ambiance/eau / Sonda temperatura ambiente/agua
4	414508038	Pressacavo / cable holder / Kabelklemme / presse-cable / presionacable
5	41451200500	Scheda madre completa / Complete mother board / Komplette Hauptplatine / Carte mère complete / Tarjeta madre completa
6	4160193	Pulsante accensione / On/Off button / Zündungstaste / Touche d'allumage / Botón encendido
7	418008030	* / * / * / * / *
8	41601103860	* / * / * / * / *
9	414508024	Ventilatore aspirazione fumi / Smoke exhaust fan / Rauchabsauggebläse / Ventilateur aspiration fumées / Ventilador aspiración de humos

9	41451209300	Encoder ventilatore estrazione fumi / Smoke exhausted fan ncoder / Encoder Rauchgasgebläse / Encoder du ventilateur extraction des fumées / Encoder ventilador humos
10	41451002300	Sonda fumi / Smoke sensore / Rauchgassonde / Sonde fumées / Sonda humos
11	41800802801	Guarnizione adesiva voluta fumi / Adhesive gasket smoke volute / Haftendichtung Rauchvolute / Joint adhesive volute fumées / Junta adhesiva voluta humos
12	41200903900	Condotto candeletta / Sparkplug conduit / Zündkerzenkanal / Conduit bougie / Conducto bujía
13	41450905000	Candeletta accensione pellet / Pellet ignition sparkplug / Zündkerze Pelletzündung / Bougie d'allumage pellet / Bujía encendido pellet
14	41401069141V	Tasca braciere / Combustion pot container / Brenntopfkasten / Récipient braséro / Contenidor brasero
15	418008027	Guarnizione / Gasket / Dichtung / Joint / Junta
16	41450901600	Motoriduttore 3,3 rpm Merkle Korff / Reduction motor 3,3 rpm Merkle Korff / Getriebemotor 3,3 RPM MERKLE KORFF / Motorréducteur 3,3 RPM MERKLE KORFF / Motorreductor 3,3 rpm Merkle Korff
17	4120398	Connettore motoriduttore-coclea / Reduction motor-feed screw connector / Verbindung Getriebemotor-Schnecke / Connecteur motorréducteur-vis sans fin / Conector motorreductor-cóclea
18	41400944351	Base della coclea / Feed screw base / Untergestell der Förderschnecke / Base de la vis sans fin / Base de la cóclea
19	4120614	Boccola grafitata (2 pz) / Etched bush (2 pcs) / Graphitbuchse (2 Stck) / Bride graphitée (2 pcs) / Brida grafitada (2 pz)
20	41400903310	Flangia condotto coclea / Base of feed screw conduit / Untergestell Rohrleitung der Förderschnecke / Base du conduit de la vis sans fin / Base de conducto de la cóclea
21	4120615	Guarnizione base della coclea / Feed screw base gasket / Dichtung Untergestell der Förderschnecke / Joint pour la base de la vis sans fin / Junta base de la cóclea
22	41200901040	Coclea di caricamento pellet / Pellet feed screw / Pelletsförderschnecke / Vis sans fin pour chargement du pellet / Cóclea de carga pellet
23	41401077540V	Condotto della coclea / Conduit of feed screw / Rohrleitung der Förderschnecke / Conduit de la vis sans fin / Conducto de la cóclea
24	418008029	Guarnizione / Gasket / Dichtung / Joint / Junta
25	41451303300	Pannello comandi / Control panel / * / Panneau de commande / *
26	41451201900	Cavo Flat L 1,4 M / Flat cable L 1,4 M / Flat Kable L 1,4 M / Câble Flat L 1,4 M / Cable Flat L 1,4 M
28	412007004	Clickson 110°C / Clickson 110°C / Clickson 110°C / Clickson 110°C / Clickson 110°C
29	41450901100	Clickson 95°C / Clickson 95°C / Clickson 95°C / Clickson 95°C / Clickson 95°C

IBIS 11 KW

Componenti interni idraulici SENZA kit acqua sanitaria / Internal plumbing components WITHOUT domestic water kit / Interne hydraulische Bauteile OHNE Brauchwassersatz / Composants hydrauliques internes SANS kit eau sanitaire / Componentes internos hidráulicos SIN kit de agua sanitaria

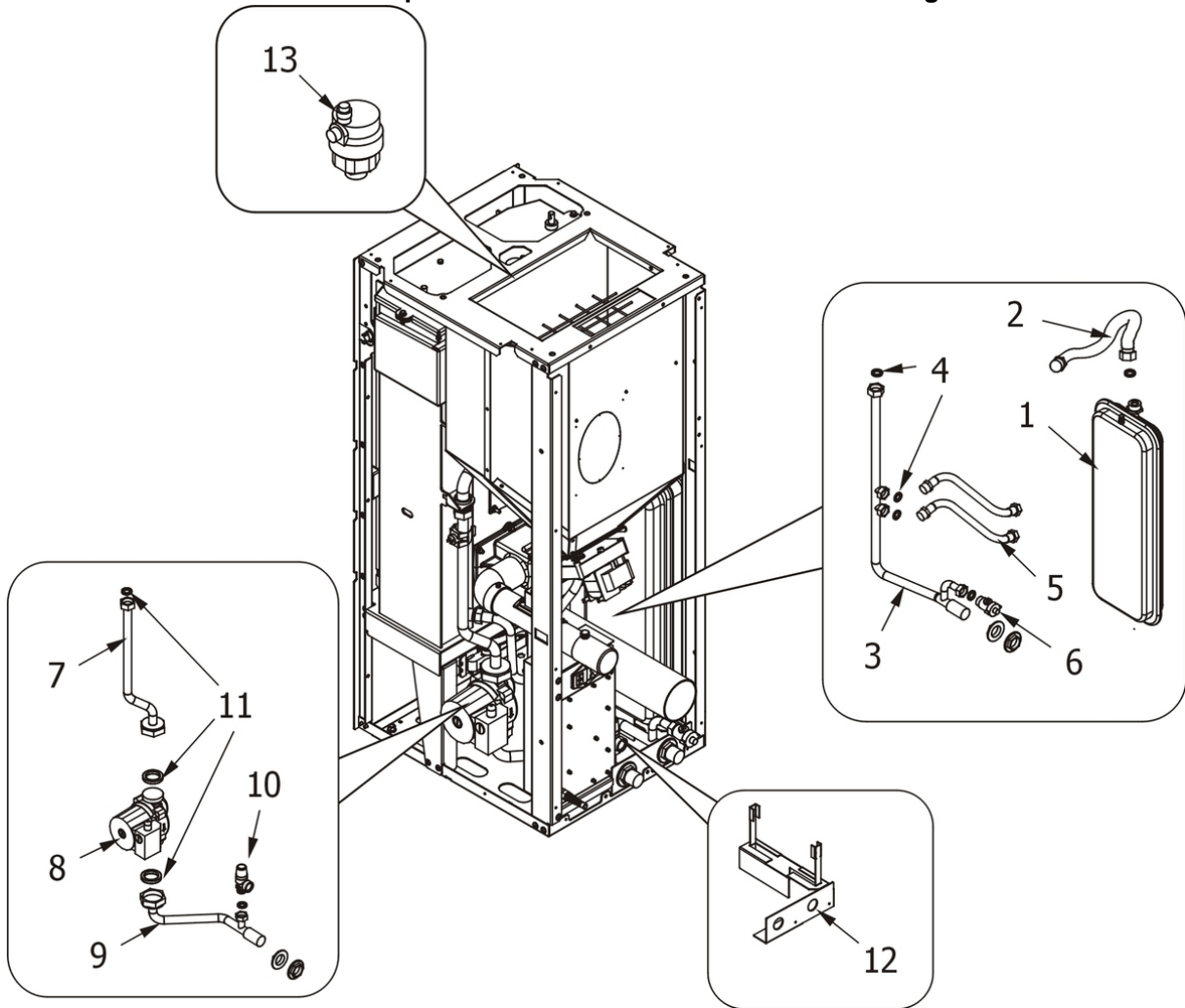

N°	Codice/Code	Descrizioni / Description / Beschreibung / Description / Description
1	4120775	Vaso espansione / Expansion vessel / Expansionsgefäß / Vase d'expansion / Vaso de expansión
2	4120781	Giunto estensibile inox 3/4" / 3/4" stainless steel flexible joint / Edelstahl Verbindungsschlauch 3/4" / Joint flexible inox 3/4" / junta flexible inox 3/4"
3	41501000900	Tubo di ritorno acqua in caldaia / Boiler water return tube / Wasserrücklaufrohr zum Kessel / Tuyau retour eau dans la chaudière / Tubo de regreso agua a la caldera
4	41207910	Kit guarnizioni impianto idraulico / Hydraulic system gasket kit / Dichtungsbausatz für Hydraulikanlage / Kit de joints pour l'installation hydraulique / Kit de juntas de la instalación de fontanería
4	41207910	Kit guarnizioni impianto idraulico / Hydraulic system gasket kit / Dichtungsbausatz für Hydraulikanlage / Kit de joints pour l'installation hydraulique / Kit de juntas de la instalación de fontanería
5	41500901300	Tubo flessibile inox 1/2" / 1/2" stainless steel flexible tube / Edelstahlschlauch 1/2" / Tuyau flexible inox 1/2" / Tubo flexible inox 1/2"
6	4160351	Rubinetto scarico 1/2" con tappo / 1/2" drain valve with plug / Ablaufhahn 1/2" mit Stopfen / Robinet évacuation 1/2" avec bouchon / Grifo de desagüe 1/2" con tapón
7	41500901000	Tubo di mandata acqua da caldaia / Boiler water delivery tube / Vorlaufrohr Wasser vom Kessel / Tuyau de refoulement eau de la chaudière / Tubo de envío de agua de la caldera
8	41501205300	Pompa alta efficienza / High efficiency pump / Hoch Effizienz Pumpe / Pompe de circulation AE / Bomba alta eficiencia
8	4D1501205200	Pompa di circolazione / Circulation pump / * / Pompe de circulation / *
9	41501201200	Tubo di mandata acqua da pompa / Water circulation pump delivery tube / Vorlaufrohr Wasser von der Pumpe / Tuyau de refoulement eau de la pompe / Tubo de envío de agua de la bomba

10	4120778	Valvola di massima pressione (3 bar) / Maximum pressure valve (3 bar) / Hochdruckventil (3 Bar) / Soupape de pression maximale (3 bar) / Válvula de máxima presión (3 bar)
11	41207910	Kit guarnizioni impianto idraulico / Hydraulic system gasket kit / Dichtungsbausatz für Hydraulikanlage / Kit de joints pour l'installation hydraulique / Kit de juntas de la instalación de fontanería
11	41207910	Kit guarnizioni impianto idraulico / Hydraulic system gasket kit / Dichtungsbausatz für Hydraulikanlage / Kit de joints pour l'installation hydraulique / Kit de juntas de la instalación de fontanería
11	41207910	Kit guarnizioni impianto idraulico / Hydraulic system gasket kit / Dichtungsbausatz für Hydraulikanlage / Kit de joints pour l'installation hydraulique / Kit de juntas de la instalación de fontanería
12	41401269530	Staffa di supporto gruppo idraulico / Hydraulic group support bracket / Haltebügel der Hydraulischen Baugruppe / Étrier support du group hydraulic / Zuncho de soporte del kit idraulico
13	4120779	Valvola di sfiato / Vent valve / Entlüftungsventil / Soupape de dégagement / Válvula respiradero

IBIS 11 KW

Gruppo scambiatore / Exchanger group / Austausch Baugruppe / Groupe échangeur / Grupo intercambiador

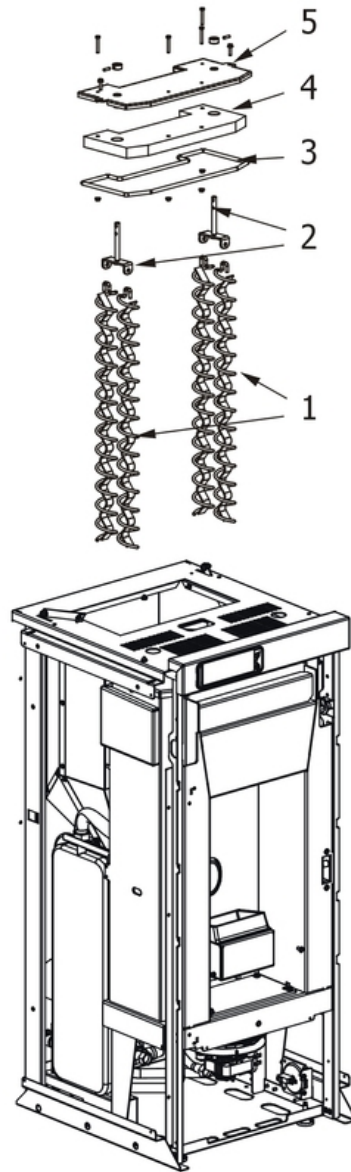

N°	Codice/Code	Descrizioni / Description / Beschreibung / Description / Descripción
1	41200903100	Turbolatori / Turbolators / * / Turbolateurs / *
2	41400914740	Staffa sostegno raschiatore / Turbulator support bar / Haltebügel der Reinigungsspirale / étrier support turbulateur / Zuncho apoyo rascador
3	4120103A	Cordino fibroceramico Ø 10 mm (5 mt.) / Ceramic fibre cord Ø 10 mm (5 m) / Keramikfaserschnur Ø 10 mm (5 m) / Cordon en fibre céramique Ø 10 mm (5 m) / Junta a cuerda de fibra cerámica Ø 10 mm (5 m)

4	41150900100	Pannello calorite coperchio caldaia / Boiler cover calorite panel / Kesseldeckepaneel aus Calorite / Panneau en calorite couvercle chaudière / Panel en calorite tapa caldera
5	41400914840V	Coperchio scambiatore / Exchanger cover / Deckel des Austauschers / Couvercle Echangeur / Tapa intercambiador