

## TECNA BLACK

Componenti Struttura Esterna / External structure components / Bauteile Aussenkorpus / Composants structure externe / Componentes estructura externa

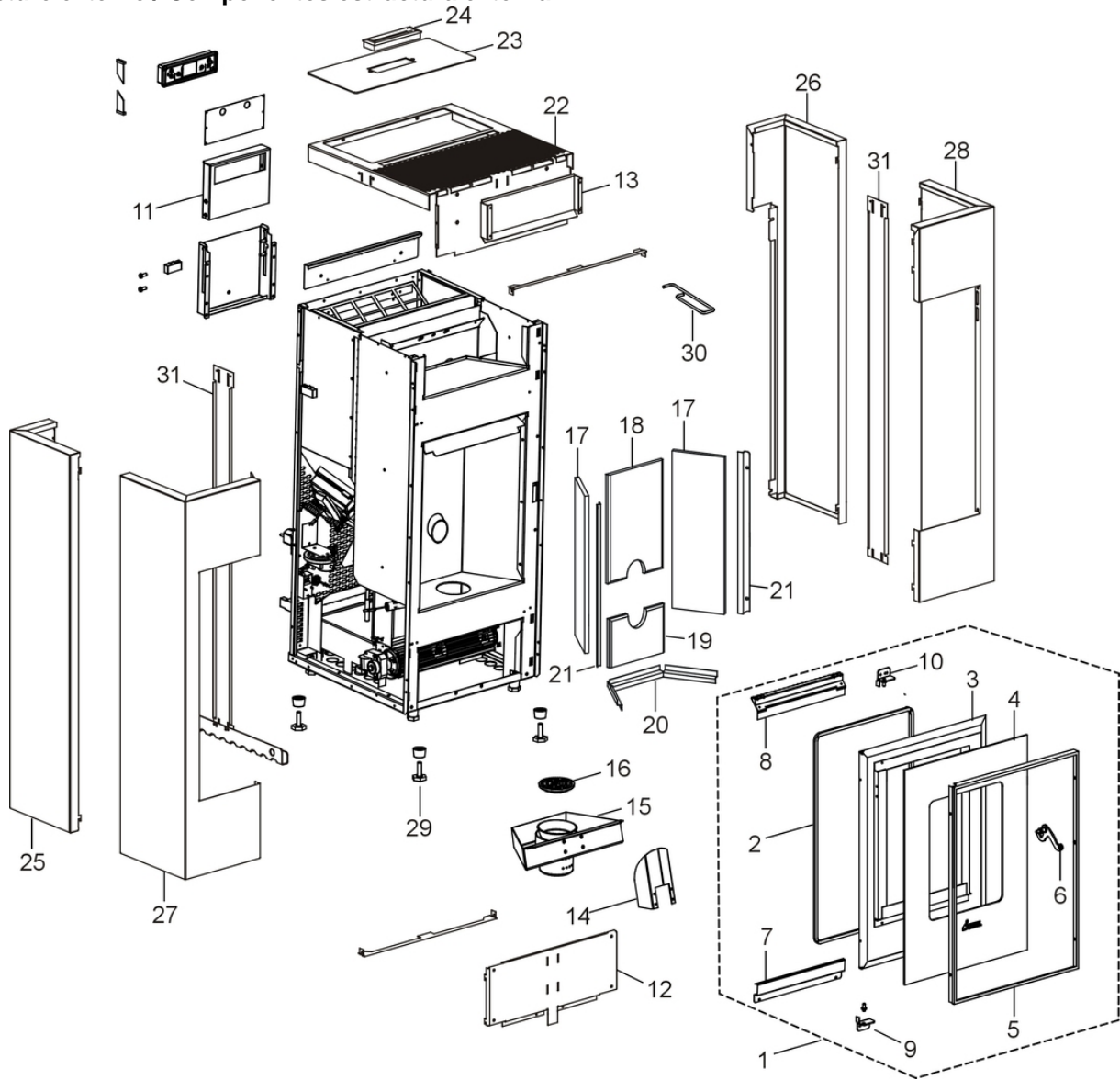

N°	Codice/Code	Descrizioni / Description / Beschreibung / Description / Descripción
1	4D245GP14006	Porta fuoco completa / Complete fire door / Komplette Feuertür / Porte foyer complète / Puerta hogar completa
2	4D18013007	Guarnizione 346X507 mm / Gasket 346X507 mm / * / Joint 346X507 mm / *
3	4D24014516461	Telaio porta fuoco / Fire door frame / Feuertürrahmen / Cadre porte foyer / Armazón puerta hogar
4	4D170145010	Vetroceramico 533x374x4 mm / Glass 533x374x4 mm / Glasskeramikscheibe 533x374x4 mm / Vitrocéramique 533x374x4 mm / Cristal cerámico 533x374x4 mm
5	4D24014520361	Telaio supporto vetro / Glass frame / Scheibenrahmen / Cadre support vitre / Armazón cristal
6	4D120145010	Maniglia / Handle / Griff / Poignée / Tirador
7	4D241145053	Fermavetro inferiore / Lower glass fastening brackets / Unteres Haltebügel für Scheibenbefestigung / Etrier inférieur de fixation de la vitre / Retendor inferior del cristal
8	4D241145063	Fermavetro superiore / Upper glass fastening brackets / Oberes Haltebügel für Scheibenbefestigung / Etrier supérieur de fixation de la vitre / Retendor superior del cristal
9	4D24014515361	Supporto porta / Door support / Türhalterung / Support porte / Soporte puerta
10	4D24014514361	Supporto porta / Door support / Türhalterung / Support porte / Soporte puerta
11	4D24014033363	Supporto pannello comandi / Display suport / Display halterung / Support pour le panneau de comande / Soporte panel de mandos
12	4D24014505363	Frontalino inferiore / Lower filler / Untere Stopfung / Plaque inférieure / Tapa inferior

13	4D24014523361	Deffettore frontale nero / Black frontal deflector / Schwarze vordere Leitblech / Deflecteur frontal noir / Deflector frontal negro
14	4D242145013	Parafiamma / Flame deflector / Flammenschutzteil / Pare-flamme / Deflector
15	4D24014521061	Braciere con griglia / Brazier with grille / Brennschale mit Gitter / Brasero avec grille / Brasero con rejilla
15	4D14013138	Braciere completo di griglia / Complet ash drawer with grille / Komplette Brennschale mit Gitter / Brasero complet avec grille / Brasero completo con rejilla
16	4D13012005	Griglia braciere / Ash drawer grille / * / Grille brasero / *
17	4D115145020	Laterale in Vermiculite 130x390x10 mm / Vermiculite side 130x390x10 mm / Seite aus Vermiculite 130x390x10 mm / Côté en Vermiculite 130x390x10 mm / Placa lateral de Vermiculite 130x390x10 mm
17	4D115145020	Laterale in Vermiculite 130x390x10 mm / Vermiculite side 130x390x10 mm / Seite aus Vermiculite 130x390x10 mm / Côté en Vermiculite 130x390x10 mm / Placa lateral de Vermiculite 130x390x10 mm
18	4D115145010	Schiena superiore in Vermiculite 168x390x10 mm / Upper Vermiculite back 168x390x10 mm / Oberes Rückwand aus Vermiculite 168x390x10 mm / Fond supérieur en Vermiculite 168x390x10 mm / Parte trasera superior de Vermiculite 168x390x10 mm
19	4D115145030	Schiena inferiore in Vermiculite 168x120x10 mm / Lower Vermiculite back 168x120x10 mm / Unteres Rückwand aus Vermiculite 168x120x10 mm / Fond inférieur en Vermiculite 168x120x10 mm / Parte trasera inferior de Vermiculite 168x120x10 mm
20	4D242145033	Profilo inferiore / Lower profile / Unteres Profil / Profil inférieur / Perfil inferior
21	4D242145023	Profilo per Vermiculite / Profile for Vermiculite / Profil für Vermiculite / Profil pour Vermiculite / Perfil para Vermiculite
21	4D242145023	Profilo per Vermiculite / Profile for Vermiculite / Profil für Vermiculite / Profil pour Vermiculite / Perfil para Vermiculite
22	4D24014510361	Top nero / Black top / Schwarze Topplatte / Dessus noir / Top negro
23	4D24014511163	Coperchio serbatoio pellet / Pellet hopper cover / Deckel Pelletbehälter / Couvercle réservoir pellet / Tapadera depósito
24	4D12013068	Maniglia coperchio / Cover handle / * / Poignée couvercle / *
25	4D24014506440	Pannello posteriore SX Antracite / L. rear Charcoal side / Hintere L. Anthrazite Platte / Panneau postérieur G. Antracite / Placa posterior IZDA Antracita
25	4D24014506491	Pannello posteriore SX Rosso / L. rear Red side / Hintere L. Rot Platte / Panneau postérieur G. Rouge / Placa posterior IZDA Roja
25	4D24014506496	Pannello posteriore SX Bianco / L. rear White side / Hintere L. Weiß Platte / Panneau postérieur G. Blanc / Placa posterior IZDA Blanca
26	4D24014509440	Pannello posteriore DX Antracite / R. rear Charcoal side / Hintere R. Anthrazite Platte / Panneau postérieur D. Antracite / Placa posterior DCHA Antracita
26	4D24014509491	Pannello posteriore DX Rosso / R. rear Red side / Hintere R. Rot Platte / Panneau postérieur D. Rouge / Placa posterior DCHA Roja
26	4D24014509496	Pannello posteriore DX Bianco / R. rear White side / Hintere R. Weiß Platte / Panneau postérieur D. Blanc / Placa posterior DCHA Blanca
27	4D24014507440	Pannello anteriore SX Antracite / L. frontal Charcoal side / Vordere L. Anthrazite Platte / Panneau antérieur G. Antracite / Placa anterior IZDA Antracita
27	4D24014507491	Pannello anteriore SX Rosso / L. frontal Red side / Vordere L. Rot Platte / Panneau antérieur G. Rouge / Placa anterior IZDA Roja
27	4D24014507496	Pannello anteriore SX Bianco / L. frontal White side / Vordere L. Weiß Platte / Panneau antérieur G. Blanc / Placa anterior IZDA Blanca
28	4D24014508440	Pannello anteriore DX Antracite / R. frontal Charcoal side / Vordere R. Anthrazite Platte / Panneau antérieur D. Antracite / Placa anterior DCHA Antracita
28	4D24014508491	Pannello anteriore DX Rosso / R. frontal Red side / Vordere R. Rot Platte / Panneau antérieur D. Rouge / Placa anterior DCHA Roja
28	4D24014508496	Pannello anteriore DX Bianco / R. frontal White side / Vordere R. Weiß Platte / Panneau antérieur D. Blanc / Placa anterior DCHA Blanca
29	4D12013006	Piedini (4 pz.) / Feet (4 pcs.) / * / Vétrins (4 pcs) / *
30	4D12013060	Gancio "Mano fredda" / Hook "Cold hand" / * / Crochet "Main froide" / *
31	4D24014501363	Montante / Rod / Montageleiste / Montant / Montante
31	4D24014501363	Montante / Rod / Montageleiste / Montant / Montante

## TECNA BLACK

Componenti interni meccanici ed elettronici / Electronic and mechanic internal parts / Interne mechanische und elektronische Bauteile / Composants internes mécaniques et électroniques / Componentes internos electrónicos y mecánicos

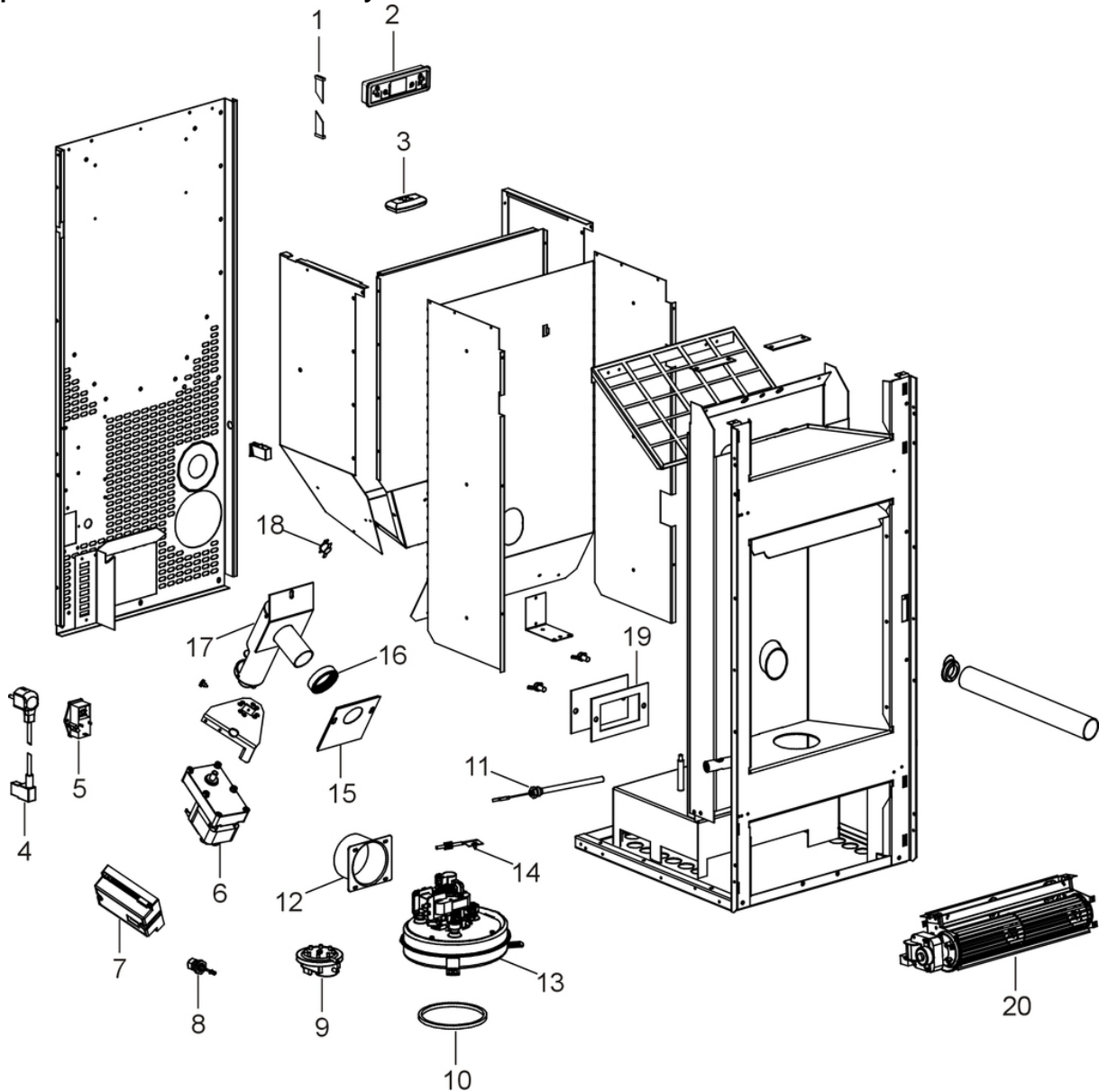

N°	Codice/Code	Descrizioni / Description / Beschreibung / Description / Descripción
1	4D14513031	Cavo flat / Flat cable / * / Câble flat / *
2	4D14513001	Pannello comandi / Control panel / * / Tableau de commande / *
2	4D14513013	Pannello comandi / Control panel / * / Tableau de commande / *
2	4D14513032	Pannello comandi / Control panel / * / Tableau de commande / *
3	4D14513055	Telecomando / Remote control / * / Télécommande / *
4	4D14513041	Cavo alimentazione + Spina / Power source cable + Plug / * / Câble alimentation + Epine / *
5	4160193	Pulsante accensione / On/Off button / Zündungstaste / Touche d'allumage / Botón encendido
6	41450901600	Motoriduttore 3,3 rpm Merkle Korff / Reduction motor 3,3 rpm Merkle Korff / Getriebemotor 3,3 RPM MERKLE KORFF / Motoréducteur 3,3 RPM MERKLE KORFF / Motorreductor 3,3 rpm Merkle Korff
6	4D14513005	Motoriduttore 5 RPM / Gear motor 5 RPM / * / Motoréducteur 5 RPM / *
7	4D14512022	Scheda madre / Motherboard / * / Carte mère / *
7	4D14513036	Scheda madre / Motherboard / * / Carte mère / *
7	4D14513036A	Scheda madre / Motherboard / * / Carte mère / *

<b>8</b>	<b>4D14513037</b>	Sonda ambiente / Room temperature sensor / * / Sonde température ambiante / *
<b>9</b>	<b>4D14513009</b>	Pressostato / Pressure switch / * / Pressostat / *
<b>10</b>	<b>4D18013024</b>	Guarnizione / Gasket / * / Joint / *
<b>11</b>	<b>4D14513002</b>	Candeletta / Sparkplug / * / Bougie / *
<b>12</b>	<b>4D14513040</b>	Raccordo D.80 mm / Connector D.80 mm / Anschlußrohr D.80 mm / Raccord D.80 mm / Racor D.80 mm
<b>13</b>	<b>41451209300</b>	Encoder ventilatore estrazione fumi / Smoke exhausted fan ncoder / Encoder Rauchgasgebläse / Encoder du ventilateur extraction des fumées / Encoder ventilador humos
<b>13</b>	<b>414508024</b>	Ventilatore aspirazione fumi / Smoke exhaust fan / Rauchabsauggebläse / Ventilateur aspiration fumées / Ventilador aspiración de humos
<b>14</b>	<b>4D14513059</b>	Sonda fumi / Smoke sensor / * / Sonde fumées / *
<b>15</b>	<b>4D18013004</b>	Guarnizione 100X108 mm / Gasket 100X108 mm / * / Joint 100X108 mm / *
<b>16</b>	<b>4D18013003</b>	Guarnizione D.50 mm / Gasket D.50 mm / * / Joint D.50 mm / *
<b>17</b>	<b>4D12013057</b>	Assieme coclea - Versione corta con albero femmina / Auger set - Short version with female shaft / * / Groupe vis sans fin - Version courte avec arbre femelle / *
<b>18</b>	<b>4D14513006</b>	Termostato 60°C / Thermostat 60°C / * / Thermostat 60°C / *
<b>19</b>	<b>4D18013001</b>	Guarnizione 130x80 mm / Gasket 130x80 mm / * / Joint 130x80 mm / *
<b>20</b>	<b>4D14513004</b>	Ventilatore aria / Air fan / * / Ventilateur air / *