

VEGA METAL

Componenti Struttura Esterna / External structure components / Bauteile Aussenkorpus / Composants structure externe / Componentes estructura externa

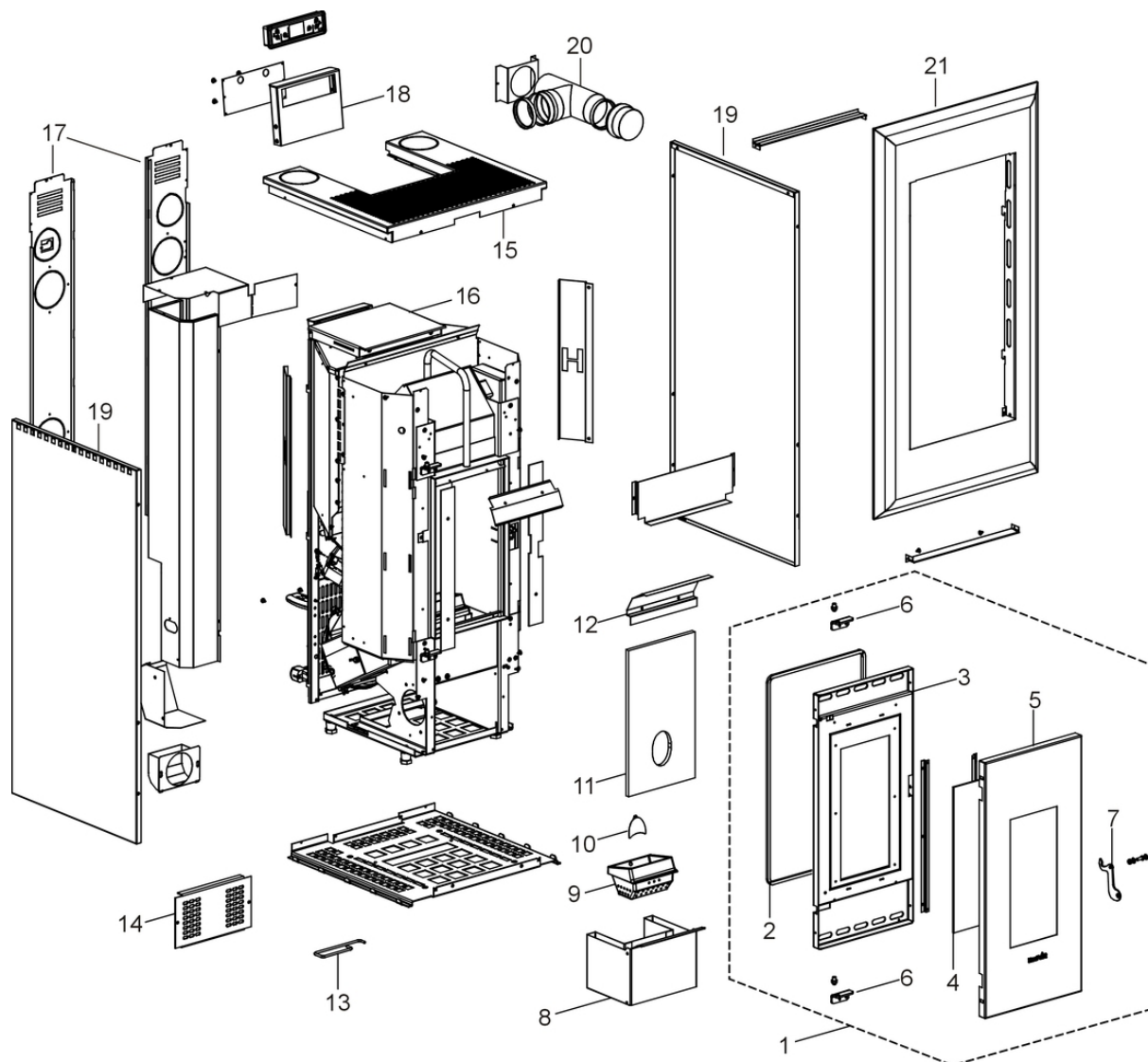

N°	Codice/Code	Descrizioni / Description / Beschreibung / Description / Description
1	4D245GP16001	Porta fuoco completa in ghisa / Cast iron complete fire door / Komplette Feuertür aus Guß / Porte foyer complète en fonte / Puerta hogar completa de arrabio
2	4D18013021A	Guarnizione treccia nera D.10 - 5 M / Black twist gasket D.10 - 5 M / Dichtung D.10 - 5 M / Joint tresse noire D.10 - 5 M / Junta D.10 - 5 M
2	4D18013021B	Guarnizione treccia nera D.10 - 50 M / Black twist gasket D.10 - 50 M / Dichtung D.10 - 50 M / Joint tresse noire D.10 - 50 M / Junta D.10 - 50 M
3	4D24014064461	Telaio porta fuoco / Fire door frame / Feuertürrahmen / Cadre porte foyer / Armazón puerta hogar
4	4D170140010	Vetroceramico 385x175x4 mm / Glass 385x175x4 mm / Glasskeramikscheibe 385x175x4 mm / Vitrocéramique 385x175x4 mm / Cristal cerámico 385x175x4 mm
4	4D170157040	Vetroceramico 379X193X4 / Ceramic glass 379X193X4 / Glaskeramikscheibe 379X193X4 / Vitrecéramique 379x193x4 mm / Cristal cerámico 379x193x4 mm
5	4D24014048361	Telaio porta esterna / External door frame / Außentürrahmen / Cadre porte extérieure / Armazón puerta exterior
5	4D13015701061	Telaio porta fuoco in ghisa / Cast iron fire door frame / Feuertürrahment aus Guß / Cadre porte foyer en fonte / Armazón puerta hogar de arrabio
6	4D2401303720	Supporto porta nero / Black door support / Schwarzes Türhaltebügel / Support porte noir / Soporte puerta negro
6	4D2401303720	Supporto porta nero / Black door support / Schwarzes Türhaltebügel / Support porte noir / Soporte puerta negro
7	4D24014066161	Maniglia / Handle / Griff / Poignée / Tirador

7	4D24015868161	Maniglia / Handle / Griff / Poignée / Tirador
7	4D24015841361	Kit decompressione camera di combustione / Pressure relief kit / Bausatz Überdruckablauf Brennkammer / Kit decompression chambre de combustion / Kit decompression cámara de combustión
8	4D24014015461	Cassetto cenere / Ash drawer / Aschenkasten / Tiroir à cendres / Cajón ceniza
9	4D13013001	Braciere / Grate / Brennschale / Brasero / Brasero
10	4D2401303101	Deflettore pellet / Pellet deflector / Pellet Leitblech / Deflecteur pellet / Deflector pellet
11	4D115140020	Schiena in Calorite / Calorite back / Rückwand aus Calorite / Fond en Calorite / Parte trasera de Calorite
12	4D242140043	Supporto Vermiculite / Vermiculite support / Vermiculite Halterung / Support Vermiculite / Soporte Vermiculite
13	4D12013060	Gancio "Mano fredda" / Hook "Cold hand" / Haken "Kalte Hand" / Crochet "Main froide" / Gancho "mano fría"
14	4D24014028363	Frontalino inferiore / Lower filler / Untere Stopfung / Plaque inférieure / Tapa inferior
15	4D24014044361	Top nero / Black top / Schwarze Topplatte / Dessus noir / Top negro
16	4D18013016	Guarnizione 155X190 mm / Gasket 155X190 mm / Dichtung 155x190 mm / Joint 155X190 mm / Junta 155X190 mm
16	4D24014020361	Coperchio serbatoio pellet / Pellet hopper cover / Deckel Pelletbehälter / Couvercle réservoir pellet / Tapadera depósito
17	4D241140223	Tamponazione posteriore / Rear filler / Hintere Stopfung / Plaque postérieure / Tapa posterior
18	4D24014033363	Supporto pannello comandi / Display support / Display halterung / Support pour le panneau de comande / Soporte panel de mandos
19	4D24014045363	Fianco nero / Black side / Schwarze Seite / Côté noir / Lateral negro
19	4D24014045363	Fianco nero / Black side / Schwarze Seite / Côté noir / Lateral negro
20	4D160140070	Raccordo a "T" + Guarnizione / T-Union + Gasket / T-Stück + Dichtung / Raccord en "T" + joint / Tuvería en te + Junta
21	6913091	Rivestimento completo Rosso / Complete Red cladding / Komplette Verkleidung Rot / Habillage complète Rouge / Revestimiento completo Rojo
21	6913092	Rivestimento completo Bianco / Complete White cladding / Komplette Verkleidung Weiß / Habillage complète Blanc / Revestimiento completo Blanco
21	6913093	Rivestimento completo Antracite / Complete Charcoal cladding / Komplette Verkleidung Anthrazit / Habillage complète Antracite / Revestimiento completo Antracita
21	6915007	Rivestimento completo metallo Moka / Complete Moka metal cladding / Komplette Verkleidung Metall Moka / Habillage complète métal Moka / Revestimiento completo metal Moka

VEGA METAL

Componenti interni meccanici ed elettronici / Electronic and mechanic internal parts / Interne mechanische und elektronische Bauteile / Composants internes mécaniques et électroniques / Componentes internos electrónicos y mecánicos

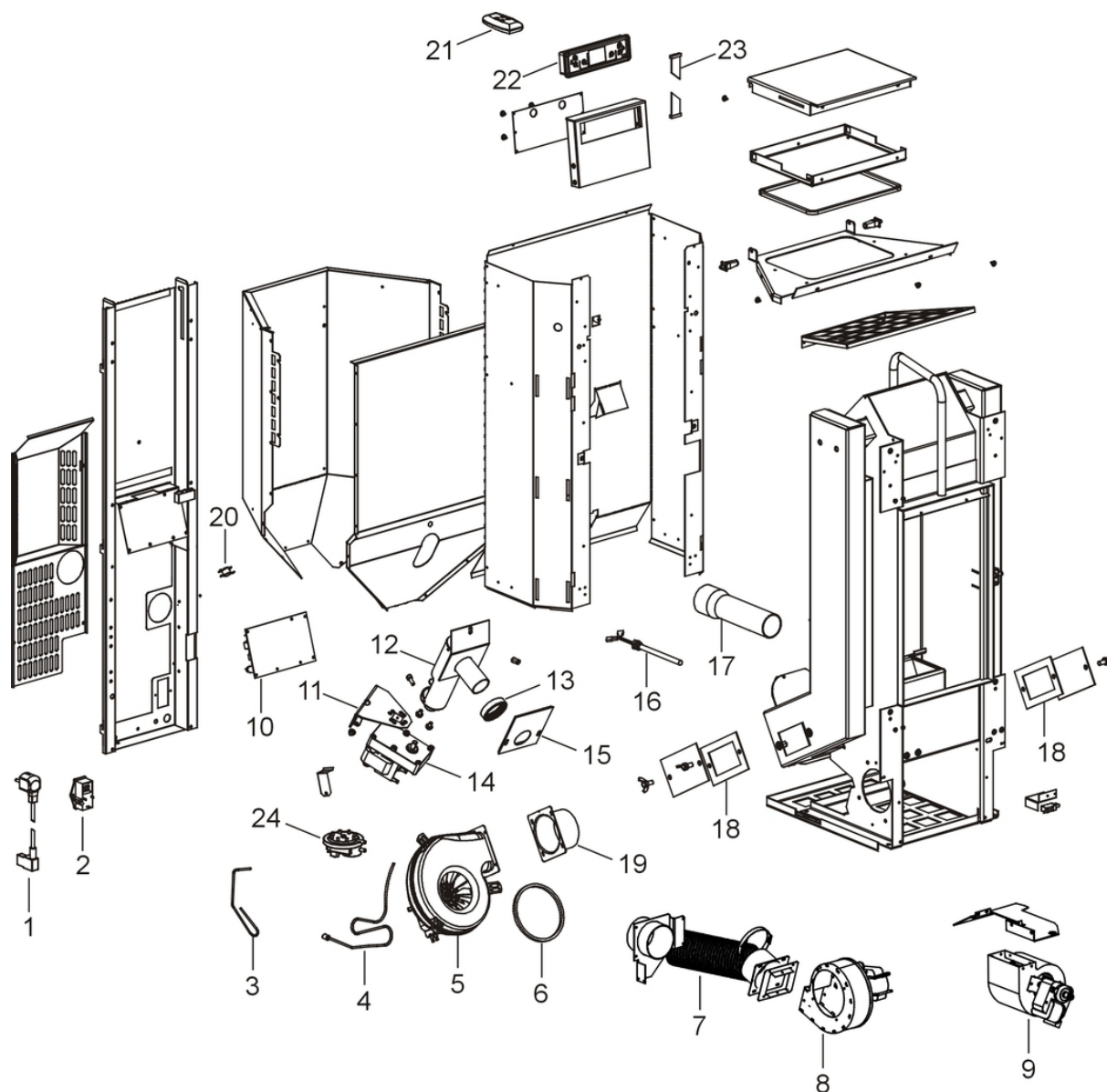

N°	Codice/Code	Descrizioni / Description / Beschreibung / Description / Descripción
1	4D14513041	Cavo alimentazione / Power source cable / Zündungskabel / Câble alimentation / Cable alimentación
2	4160193	Pulsante accensione / On/Off button / Zündungstaste / Touche d'allumage / Botón encendido
3	4D145150090	Sonda fumi / Smoke sensor / Rauchsonde / Sonde fumées / Sonda humos
4	4D14513017	Sonda ambiente / Room temperature sensor / Raumtemperaturfühler / Sonde température ambiance / Sonda ambiente
5	4D145140150	Ventilatore fumi stagno / Tin smoke fan / Hermetisch Dichtrauchgebläse / Ventilateur fumées étanche / Ventilador humos hermético
6	4D18013024	Guarnizione / Gasket / Dichtung / Joint / Junta
7	4D160140060	Tubo flessibile alluminio D.80 L.200 mm / Flexible aluminium hose D.80 L.200 mm / Aluflexrohr D.80 L.200 mm / Tuyau flexible en aluminium D.80 L.200 mm
8	4D145140010	Ventilatore aria / Air fan / Luftgebläse / Ventilateur air / Ventilador aire
9	4D14513054	Ventilatore aria / Air fan / Luftgebläse / Ventilateur air / Ventilador aire
10	4D14513064	Scheda madre / Motherboard / Hauptplatine / Carte mère / Tarjeta madre

10	4D14513064B	Scheda madre / Motherboard / Hauptplatine / Carte mère / Tarjeta madre
11	4D2401302613	Supporto coclea / Feed screw support / Schnecke Halterung / Support de la vis-sans-fin / Soporte cóclea
12	4D140160030	Coclea di caricamento pellet / Pellet feed screw / Pelletsförderschnecke / Vis sans fin pour chargement du pellet / Cóclea de carga pellet
13	4D18013003	Guarnizione D.50 mm / Gasket D.50 mm / Dichtung D.50 mm / Joint D.50 mm / Junta D.50 mm
14	4D145159010	Motoriduttore 3,3 rpm / Reduction motor 3,3 rpm / Getriebemotor 3,3 rpm / Motorréducteur 3,3 rpm / Motorreductor 3,3 rpm
15	4D18013004	Guarnizione 100X108 mm / Gasket 100X108 mm / Dichtung 100x108 mm / Joint 100X108 mm / Junta 100X108 mm
16	4D14513002	Candeletta / Sparkplug / Zündkerze Pelletzündung / Bougie / Bujía encendido pellet
17	4D160140040	Tubo ingresso aria 60x2x210 mm / Air inlet pipe 60x2x210 mm / Lufteingangrohr 60x2x210 mm / Tuyau entrée air 60x2x210 mm / Tubo entrada aire D.80 L.200 mm
18	4D18013001	Guarnizione 130x80 mm / Gasket 130x80 mm / Dichtung 130x80 mm / Joint 130x80 mm / Junta 130x80 mm
18	4D18013001	Guarnizione 130x80 mm / Gasket 130x80 mm / Dichtung 130x80 mm / Joint 130x80 mm / Junta 130x80 mm
19	4D14513040	Raccordo D.80 mm / Connector D.80 mm / Anschlußrohr D.80 mm / Raccord D.80 mm / Racor D.80 mm
20	4D14513006	Termostato 60°C / Thermostat 60°C / Thermostat 60°C / Thermostat 60°C / Termostato 60°C
21	4D14513055	Telecomando / Remote control / Fernbedienung / Télécommande / Mando a distancia
22	4D14513032	Pannello comandi / Control panel / Bedienblende / Tableau de commande / Panel de mandos
23	4D14513007	Cavo flat scheda-pannello / Flat cable motherboard-control panel / Flat Kabel Hauptplatine-Bedienblende / Câble flat carte mère-panneau commande / Cable flat tarjeta madre-panel de mandos
24	4D14513009	Pressostato / Pressure switch / Druckwächter / Pressostat / Presostato
25	4D241140013	Carter posteriore / Back carter / Hinteres Blech / Protection arrière / Carter trasero