

BERG MAESTRO

Rivestimento / Cladding / Verkleidung / Habillage / Revestimiento

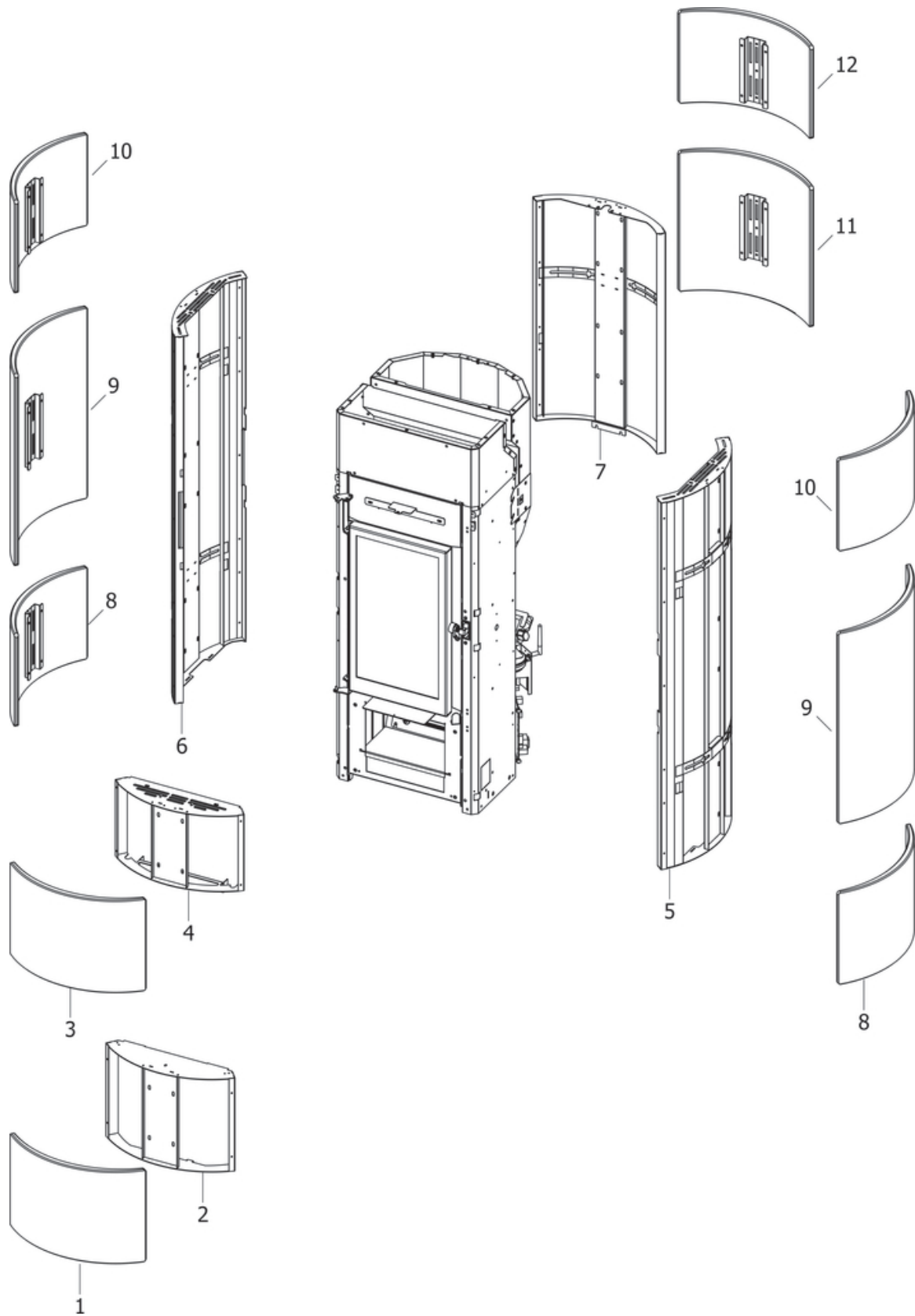

N°	Codice/Code	Descrizioni / Description / Beschreibung / Description / Descripción
1	41251603650	Pietra inferiore Serpentino / Lower Serpentine stone / Untere Stein aus Serpentino / Pierre inférieure Serpentine / Piedra inferior Serpentino
2	41411626840P	Telaio inferiore nero / Black lower frame / Schwarz untere Rahmen / Cadre inférieur noir / Armazón inferior negro
3	41251603750	Pietra superiore Serpentino / Upper Serpentine stone / Obere Stein aus Serpentino / Pierre supérieur Serpentine / Piedra superior Serpentino
4	41411627540P	Telaio superiore nero / Black upper frame / Schwarz obere Rahmen / Cadre supérieur noir / Armazón superior negro
5	41411625440P	Telaio laterale nero / Black lateral frame / Schwarz seitliche Rahmen / Cadre latéral noir / Armazón lateral negro
6	41411625440P	Telaio laterale nero / Black lateral frame / Schwarz seitliche Rahmen / Cadre latéral noir / Armazón lateral negro
7	41411626140P	Telaio supporto ceramica posteriore / Rear ceramic support frame / Hinterekeramik Rahmen / Cadre céramique postérieure / Armazón cerámica posterior
8	41251603650	Pietra inferiore Serpentino / Lower Serpentine stone / Untere Stein aus Serpentino / Pierre inférieure Serpentine / Piedra inferior Serpentino
8	41251603650	Pietra inferiore Serpentino / Lower Serpentine stone / Untere Stein aus Serpentino / Pierre inférieure Serpentine / Piedra inferior Serpentino
9	41251603850	Pietra laterale Serpentino / Lateral Serpentine stone / Seitliche Stein aus Serpentino / Pierre latérale Serpentine / Piedra lateral Serpentino
9	41251603850	Pietra laterale Serpentino / Lateral Serpentine stone / Seitliche Stein aus Serpentino / Pierre latérale Serpentine / Piedra lateral Serpentino
10	41251603750	Pietra superiore Serpentino / Upper Serpentine stone / Obere Stein aus Serpentino / Pierre supérieur Serpentine / Piedra superior Serpentino
10	41251603750	Pietra superiore Serpentino / Upper Serpentine stone / Obere Stein aus Serpentino / Pierre supérieur Serpentine / Piedra superior Serpentino
11	41251603950	Pietra posteriore Serpentino / Rear Serpentine stone / Hintere Stein aus Serpentino / Pierre postérieur Serpentine / Piedra posterior Serpentino
12	41251603750	Pietra superiore Serpentino / Upper Serpentine stone / Obere Stein aus Serpentino / Pierre supérieur Serpentine / Piedra superior Serpentino

BERG MAESTRO

Gruppo estetico / Aesthetic group / Aesthetische Gruppe / Groupe esthétique / Grupo estético

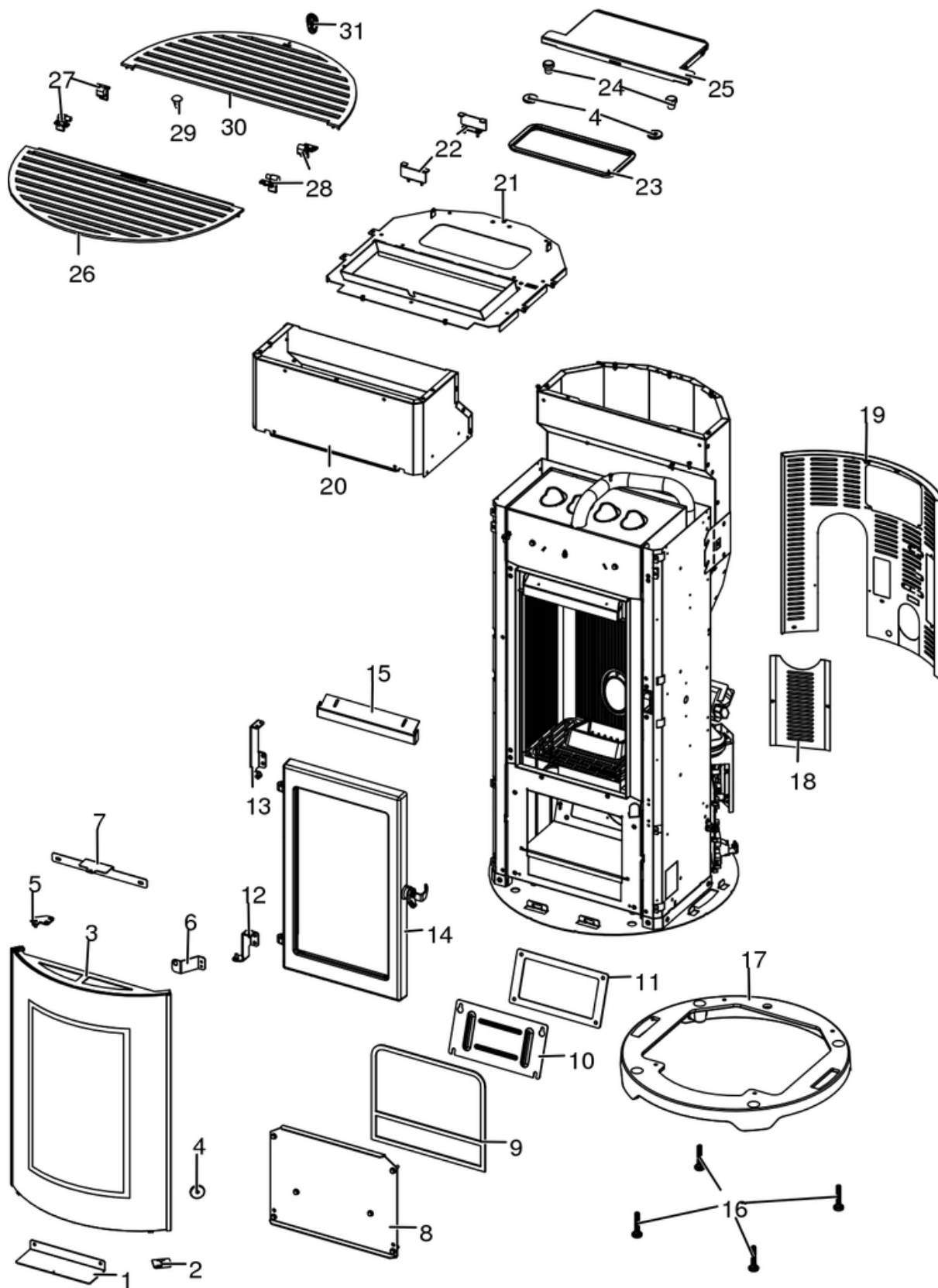

N°	Codice/Code	Descrizioni / Description / Beschreibung / Description / Description
----	-------------	--

1	41411614630V	Supporto frontale inferiore / Lower panel support / Untere Vordere Gestell / Support panneau frontal inferieur / Soporte panel frontal inferior
2	41411658860	Maniglia porta esterna / External door handle / Außentür Griff / Poignée porte extérieur / Tirador puerta exterior
3	437016142	Porta estetica / Aesthetic door / Ästhetische Tür / Porte esthétique / Puerta estética
4	41801657900	Magneti (pz.2) / Magnet (pcs.2) / Magnet (stk. 2) / Aimant (pcs.2) / Imán (pz.2)
5	41411614940V	Blocco cerniera superiore / Upper hinge stop / Obere Scharnierstopper / Stop charnière supérieure / Tope bisagra superior
6	41411663030V	Staffa appoggio porta / Door support bracket / Haltebügel der tür / Étrier support porte / Abrazadera de soporte puerta
7	41401609930	Supporto frontale superiore / Upper front support / Obere Vordere Gestell / Support panneau antérieur supérieur / Soporte panel frontal superior
8	437016050	Tappo inferiore / Lower cover / Untere Abdeckung / Couvercle inférieur / Tapón inferior
9	4120573A	Guarnizione a nastro 8 mm (5 mt.) per porta / Door strip gasket 8 mm (5 m) / Türbanddichtung 8 mm (5 m) / Joint ruban 8 mm (5 m) pour porte / Guarnición de cinta para puerta 8 mm (5 m)
9	4120573B	Guarnizione a nastro 8 mm (50 mt.) per porta / Door strip gasket 8 mm (50 m) / Türbanddichtung 8 mm (50 m) / Joint ruban 8 mm (50 m) pour porte / Guarnición de cinta para puerta 8 mm (50 m)
10	41401339610	Tappo ispezione vano fumi / Smoke compartment inspection plug / Inspektionsdeckel Rauchabzug / Clapet inspection compartiment fumées / Tapón inspección compartimento humos
11	41800900600	Guarnizione / Gasket / Dichtung / Joint / Junta
11	41801599750	Kit 50 guarnizioni / Kit 50 gaskets / Bausatz 50 Dichtungen / Kit 50 joints / Kit 50 juntas
12	41411730740V	Cerniera inf.porta ghisa / Lower hinge for cast iron door / Unterer Scharnier für Tür aus Guß / Charnière inférieure pour porte en fonte / Bisagra inferior por porta en arrabio
12	41411614740V	Cerniera inferiore nera / Black lower hinge / Schwarzes unteres Scharnier / Charnière inférieure noire / Bisagra inferior negra
13	41411730840V	Cerniera superiore / Upper hinge / Oberes Scharnier / Charnière supérieure / Bisagra superior
13	41411614830V	Cerniera superiore sera / Black upper hinge / Schwarzes oberes Scharnier / Charnière supérieure noire / Bisagra superior negra
14	437017082	Porta fuoco in ghisa / Cast iron fireplace door / Feuertür aus Gusseisen / Porte foyer en fonte / Puerta hogar de arrabio
14	437016055	Porta focolare in lamiera / Metal sheet fire door / Feuerstelle Tür / Porte foyer / Puerta hogar
15	41411615430V	Deflettore aria / Air deflector / Luftleitblech / Déflecteur aire / Deflector aire
16	41200906660	Piedini di appoggio (4 pz.) / Support feet (4 pcs.) / Einstellfüße (4 Stck.) / Vérins d'appui (4 p.es) / Pies de apoyo (4 piezas)
17	41301600900P	Basamento in ghisa / Cast iron base / Basis auf gussseisen / Base en fonte / Base de arrabio
18	41411624230P	Flangia pannello ispezione nera / Inspection panel black flange / Inspektionklappe Schwarzflansch / Bride noir trappe inspection / Brida negra tapa inspección
19	41411759940P	Schiena esterna / External back / Externe Rückseite / Dos externe / Parte trasera esterna
19	4140183193000	Schiena esterna / External back / Externe Rückseite / Dos externe / Parte trasera esterna
19	4140172540000	Carter motoriduttore / Crankcase for geared motor / Kurbelgehäuse für Getriebemotor / Carter pour le motoréducteur / Cáster para motorreductor
20	41411624150	Convogliatore aria / Air conveyor / Luftblech / Convoyeur air / Conductor del aire
21	41411614240V	Supporto top completo / Top support / Deckelhaltebügel / Support du dessus / Soporte top
22	41411625030V	Supporto top / Top support / Deckelhaltebügel / Support du dessus / Soporte del top
23	41801601400	Guarnizione coperchio serbatoio / Pellet hopper cover gasket / Deckel Pelletbehälter Dichtung / Joint couvercle réservoir pellet / Junta tapa depósito pellet
24	4120180	Gommini paracolpi (4 pz) / Rubber bumpers (4 pcs.) / Schlagschutzgummi (4 Stck) / Pièces caoutchouc antichoc (4 pcs) / Cauchitos anti-golpes (4 pz)
25	437016053	Coperchio serbatoio / Hopper cover / Deckel Pelletbehälter / Couvercle réservoir / Tapa depósito
26	41411624340P	Top fisso nero / Top / Abdeckplatte / Dessous / Top
27	41411624930P	Staffa SX / L. Bracket / Li. Bügel / Étrier G. / Abrazadera IZDA
28	41411624830P	Staffa DX / R. Bracket / RE. Bügel / Étrier D. / Abrazadera DCHA
29	41801002300	Paracolpi in silicone Ø 8/5 (2pz) / Silicone bumpers Ø 8/5 (2pcs) / Schlagschutzgummi Ø 8/5 (2 Stck) / Pièces silicone antichoc Ø 8/5 (2pcs) / Anti-golpes en silicona Ø 8/5 (2pzs)
30	41411624640P	Top mobile nero / Black amovable top / Schwarze abnehmbares Deckel / TOP noir démontable / Top negroamovible
31	41801602200	Maniglia silicónica / silicone handle / Silikongriff / Poignée de silicone / Tirador de silicona

BERG MAESTRO

Porta fuoco in ghisa / Cast iron fireplace door / Feuertür aus Gusseisen / Porte foyer en fonte / Puerta hogar de arrabio

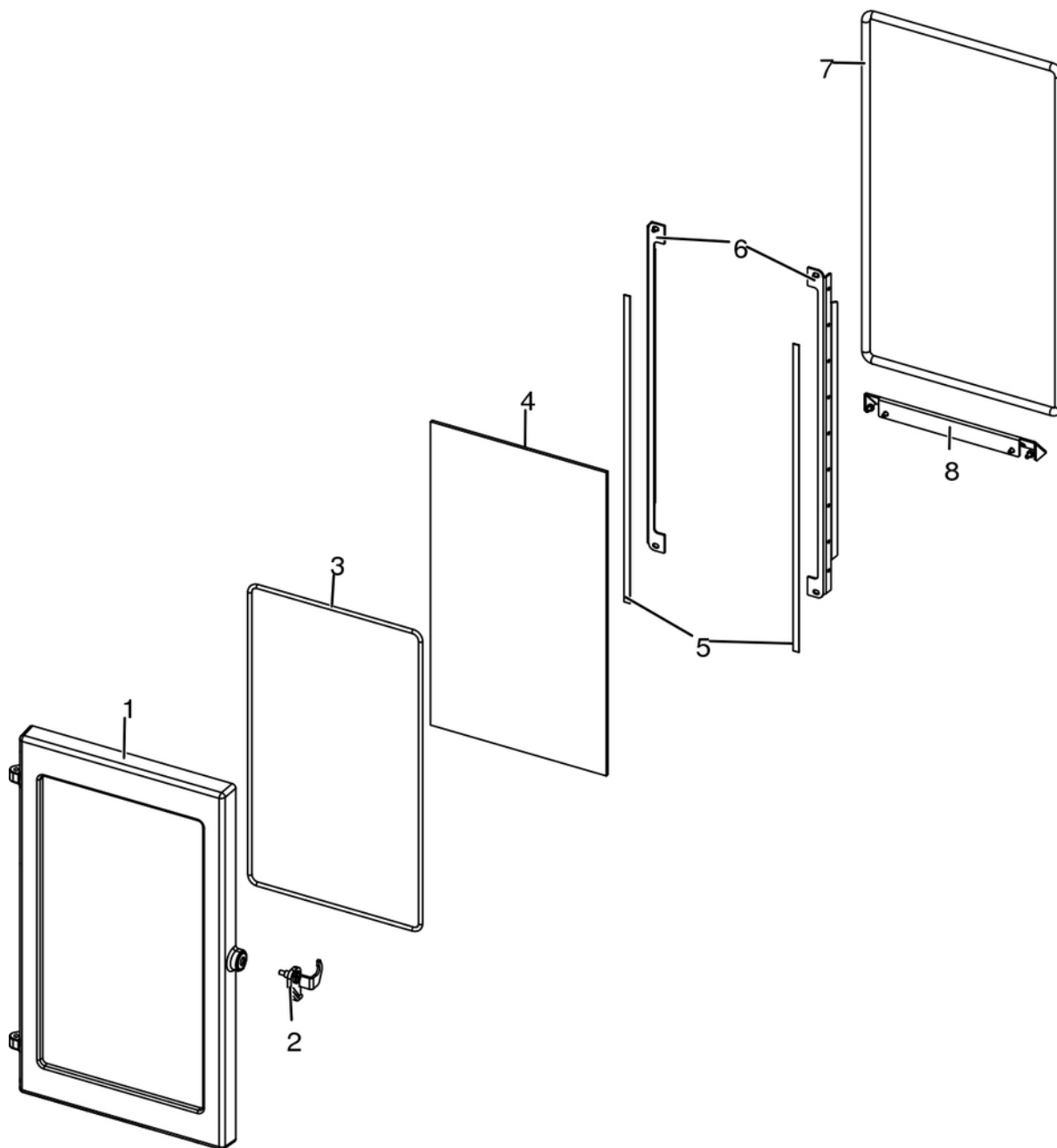

N°	Codice/Code	Descrizioni / Description / Beschreibung / Description / Description
1	41301602500V	Telaio porta fuoco / Fire door frame / Feuerrahmen / Cadre porte foyer / Armazón puerta de arrabio
2	41411616560	Maniglia porta nera / Door Handle / Türgriff / Poignée porte / Tirador
3	41801603300A	Guarnizione Ø5 5mt / Gasket Ø5 5mt / Dichtung Ø5 5mt / Joint Ø5 5mt / Junta Ø5 5mt
3	41801603300B	Guarnizione Ø5 50mt / Gasket Ø5 50mt / Dichtung Ø5 50mt / Joint Ø5 50mt / Junta Ø5 50mt
3	41801603300C	Guarnizione Ø5 5mt + silicone / Gasket Ø5 5mt + silic / Dichtung Ø5 5mt + Silikon / Joint Ø5 5mt + silic / Junta Ø5 5mt
4	41701600300	Vetroceramico porta ghisa / Cast iron door glass / Glaskeramikscheibe Tür aus Gusseise / Vitrocéremique porte en fonte / Cristal cerámico puerta en arrabio
5	4120573A	Guarnizione a nastro 8 mm (5 mt.) per porta / Door strip gasket 8 mm (5 m) / Türbanddichtung 8 mm (5 m) / Joint ruban 8 mm (5 m) pour porte / Guarnición de cinta para puerta 8 mm (5 m)

5	4120573B	Guarnizione a nastro 8 mm (50 mt.) per porta / Door strip gasket 8 mm (50 m) / Türbanddichtung 8 mm (50 m) / Joint ruban 8 mm (50 m) pour porte / Guarnición de cinta para puerta 8 mm (50 m)
6	41411622030V	Profilo fermavetro / Fastening bracket profile / Haltebügel für Scheibebefestigung Profil / Profil patte de fixation / Perfil fermacristal
7	4120104A	Cordino fibroceramico Ø 12 mm (5 mt.) / Ceramic fibre cord Ø 12 mm (5 m.) / Keramikfaserschnur Ø 12 mm (5 m) / Cordon en fibre céramique Ø 12 mm (5 m) / Junta a cuerda de fibra cerámica Ø 12 mm (5 m)
7	4120104B	Cordino fibroceramico Ø 12 mm (50 mt.) / Ceramic fibre cord Ø 12 mm (50 m.) / Keramikfaserschnur Ø 12 mm (50 m) / Cordon en fibre céramique Ø 12 mm (50 m) / Junta a cuerda de fibra cerámica Ø 10 mm (52 m)
7	41201041	Kit sostituzione cordino (cordino+silicone) Ø 12 mm / Cord replacement kit (cord + silicon) Ø 12 mm / Schnuraustauschsatz (Schnur+Silikon) Ø 12 mm / Kit remplacement cordon (cordon + silicone) Ø 12 mm / Kit sustitución junta a cuerda (junta a cuerda+silicón) Ø 12 mm
8	41411622130V	Scivolo cenere / Ash ramp / Aschenrutsche / Glissière cendre / Tobogán ceniza

BERG MAESTRO

Gruppo camera di combustione / Combustion chamber group / Verbrennungskammer Gruppe / Group de chambre de combustion / Grupo cámara de combustión

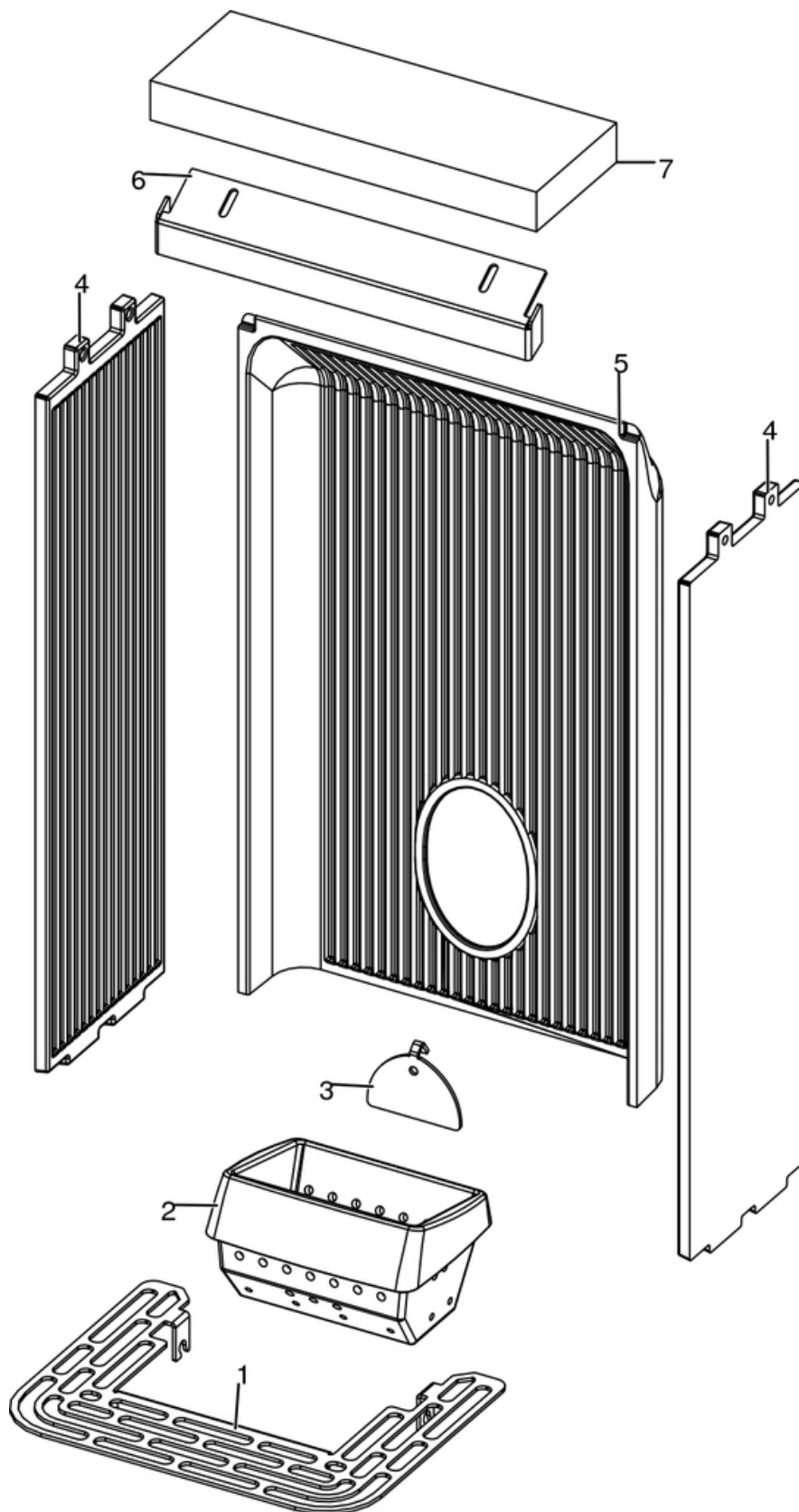

N°	Codice/Code	Descrizioni / Description / Beschreibung / Description / Descripcion
1	41411634830V	Griglia focolare / Fire Box Grille / Feuerstellenrost / Grille Foyer / Rejilla Hogar
2	41301502400V	Braciare ghisa / Cast iron grate / Brennertopf aus Gusseisen / Brasero en fonte / Brasero en arrabio
3	41411613530V	Deflettore pellet / Pellet deflector / Pellet Leitblech / Deflecteur pellet / Deflector pellet
4	41301502500V	Fianco ghisa / Cast iron side / Seite aus Guß / Côté en fonte / Placa lateral de arrabio
5	41301502600V	Schiena ghisa / Cast iron back / Rückwand aus Gusseisen / Dossieret en fonte / Parte trasera en arrabio
6	41411615430V	Deflettore aria / Air deflector / Luftleitblech / Déflecteur aire / Deflector aire
7	41151600200	Deflettore focolare in vermiculite / Vermiculite deflector / Leitblech aus Vermiculite / Déflecteur en vermiculite / Deflector en vermiculite

BERG MAESTRO

Porta estetica / Aesthetic door / Aesthetische Tür / Porte esthétique / Puerta estética

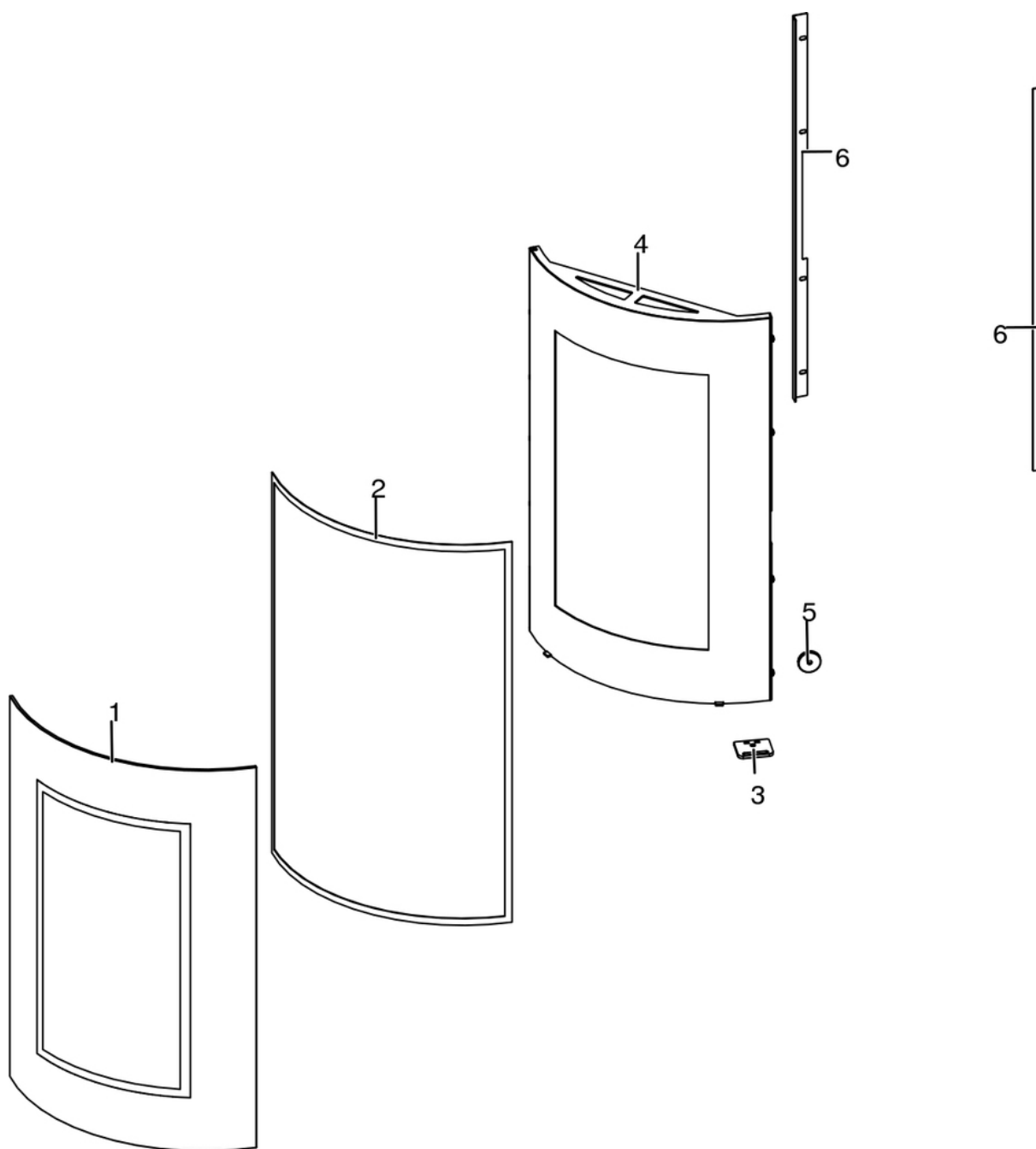

N°	Codice/Code	Descrizioni / Description / Beschreibung / Description / Description
1	41701500660	Vetroceramico / Ceramic glass / Glaskeramikscheibe / Vitre céramique / Cristal cerámico
1	41701802100	Vetro temperato / Tempered glass / Gehärtete Glasscheibe / Vitre trempé / Cristal templado
2	4120572A	Guarnizione a nastro 6 mm (5 mt.) per porta / Door strip gasket 6 mm (5 m) / Türbanddichtung 6 mm (5 m) / Joint ruban 6 mm (5 m) pour porte / Guarnición de cinta para puerta 6 mm (5 m)
2	4120572B	Guarnizione a nastro 6 mm (50 mt.) per porta / Door strip gasket 6 mm (50 m) / Türbanddichtung 6 mm (50 m) / Joint ruban 6 mm (50 m) pour porte / Guarnición de cinta para puerta 6 mm (50 m)
3	41411658860	Maniglia porta esterna / External door handle / Außentür Griff / Poignée porte extérieur / Tirador puerta exterior
4	41421601040V	Porta esterna / Complete External Door / Komplette Außentür / Porte Extérieure Complète / Puerta Exterior Completa
5	41801657900	Magneti (pz.2) / Magnet (pcs.2) / Magnet (stk. 2) / Aimant (pcs.2) / Imán (pz.2)

6	41411617230P	Fermavetro per vetro ceramico / Glass fastening bracket for ceramic glass / Haltebügel für Scheibebefestigung für Glaskeramikscheibe / Etrier de fixation vitre pour vitre céramique / Retendor del cristal para cristal cerámico
6	4141161723100	Fermavetro per vetro temperato / Glass fastening bracket for tempered glass / Haltebügel für Scheibebefestigung für gehärtete Glasscheibe / Etrier de fixation vitre pour vitre trempé / Retendor del cristal para cristal templado

BERG MAESTRO

Gruppo caricamento pellet con ragno / Pellet feed group with spider / Pellet Fördergruppe mit Spinne / Groupe chargement du pellet avec araignée / Grupo de carga pellet con cardán

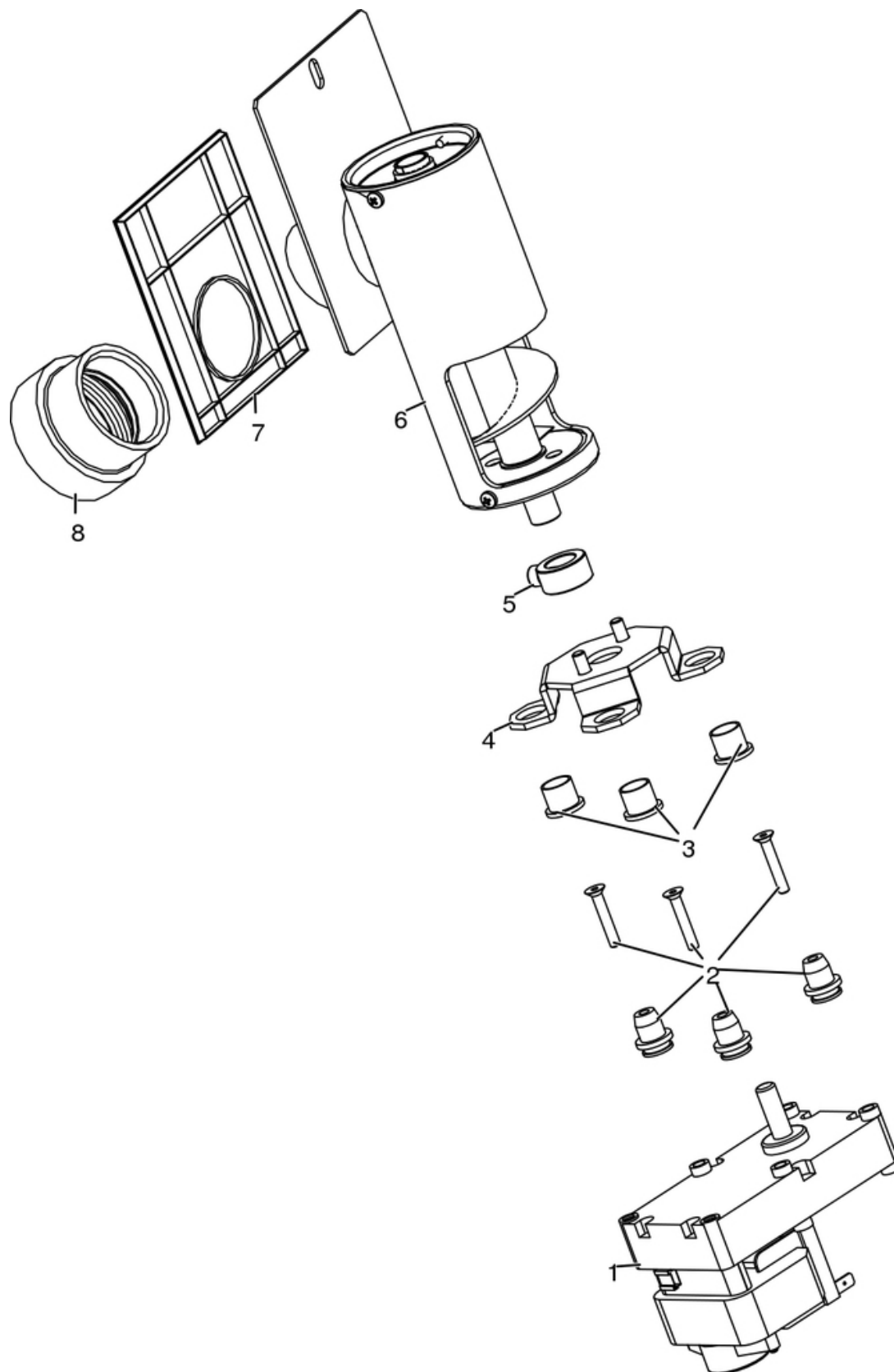

N°	Codice/Code	Descrizioni / Description / Beschreibung / Description / Descripción
1	41451503100	Motoriduttore 2rpm / Gear motor 2rpm / Getriebemotor 2rpm / Motoréducteur 2rpm / Motorreductor 2rpm
2	41801703700	Gommini antivibrante / Vibration damper rubber / Rammschutz Gummi / Caoutchouc antivibratoire / Cauchitos antivibración
3	41201800700	Boccola (3 pz) / Bushing (3 pcs) / Buchse (3 Stk) / Douille (3 pcs) / Abrazadera (3 pzs)
4	41411779331	Supporto coclea "Ragno" / Pellet feed screw bracket "spider" / "Spinne" Schenke Gestell / Support vis sans fin "Araignée" / Soporte coclea "Araña"
5	4120398	Connettore motoriduttore-coclea / Reduction motor-feed screw connector / Verbindung Getriebemotor-Schnecke / Connecteur motoréducteur-vis sans fin / Conector motorreductor-cóclea
6	41411800151	Gruppo alimentazione completo / Complete feed screw / Komplette Förderschnecke / Vis sans fin complète / Coclea de carga completa
7	41801600400	Guarnizione gruppo caricamento / Gasket / Dichtung / Joint / Junta
8	41801702600	Disaccoppiatore mesc. Marrone / Brown disengaging device / Braun Verängungsrohr / Tuyau de découplage maron / Tubo de desvío marron

BERG MAESTRO

Gruppo caricamento pellet con cardano / Pellet feed group with cardan / Pellet Fördergruppe mit Kardan / Groupe chargement du pellet avec cardan / Gruppo caricamento pellet con cardano

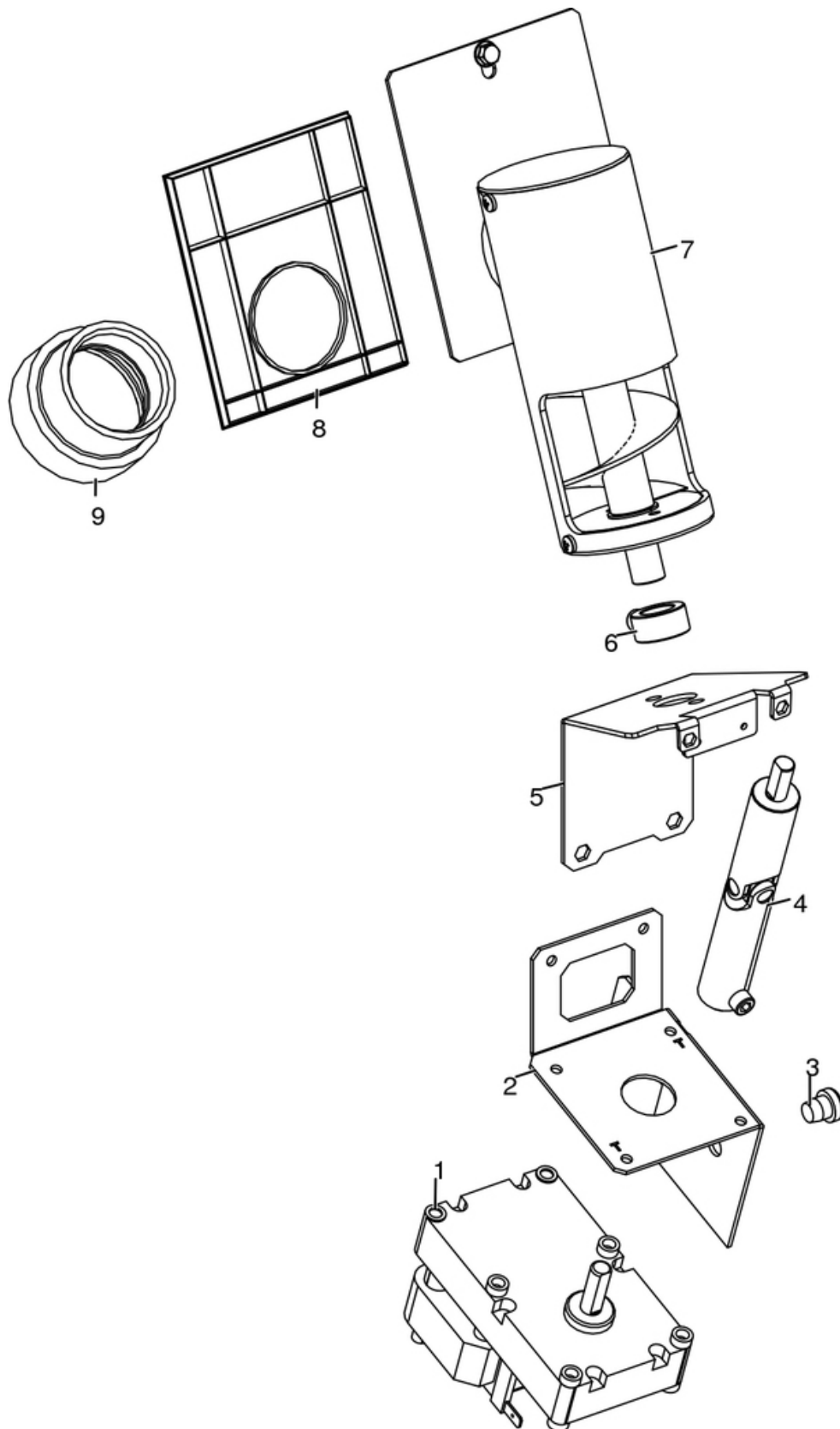

N°	Codice/Code	Descrizioni / Description / Beschreibung / Description / Descripción
1	41451503100	Motoriduttore 2rpm / Gear motor 2rpm / Getriebemotor 2rpm / Motoréducteur 2rpm / Motorreductor 2rpm
2	41401609830	Supporto motoriduttore / Reduction motor support / Schneckenmotor Gestell / Support motoréducteur / Soporte motoreductor
3	4120180	Gommini paracolpi (4 pz) / Rubber bumpers (4 pcs.) / Schlagschutzgummi (4 Stck) / Pièces caoutchouc antichoc (4 pcs) / Cauchitos anti-golpes (4 pz)
4	41801604200	Cardano / Cardan / Kardan / Cardan / Cardán
5	41401612630	Base coclea pellet / Feed screw base / Untergestell der Förderschnecke / Base de la vis sans fin / Base de la cóclea
6	4120398	Connettore motoriduttore-coclea / Reduction motor-feed screw connector / Verbindung Getriebemotor-Schnecke / Connecteur motoréducteur-vis sans fin / Conector motorreductor-cóclea
7	41411800151	Gruppo alimentazione completo / Complete feed screw / Komplette Förderschnecke / Vis sans fin complète / Coclea de carga completa
8	41801600400	Guarnizione gruppo caricamento / Gasket / Dichtung / Joint / Junta
9	41801702600	Disaccoppiatore mesc. Marrone / Brown disengaging device / Braun Verängungsrohr / Tuyau de découplage maron / Tubo de desvío marron

BERG MAESTRO

Gruppo accensione / Ignition group / Entzündung Gruppe / Groupe d'allumage / Grupo ignición

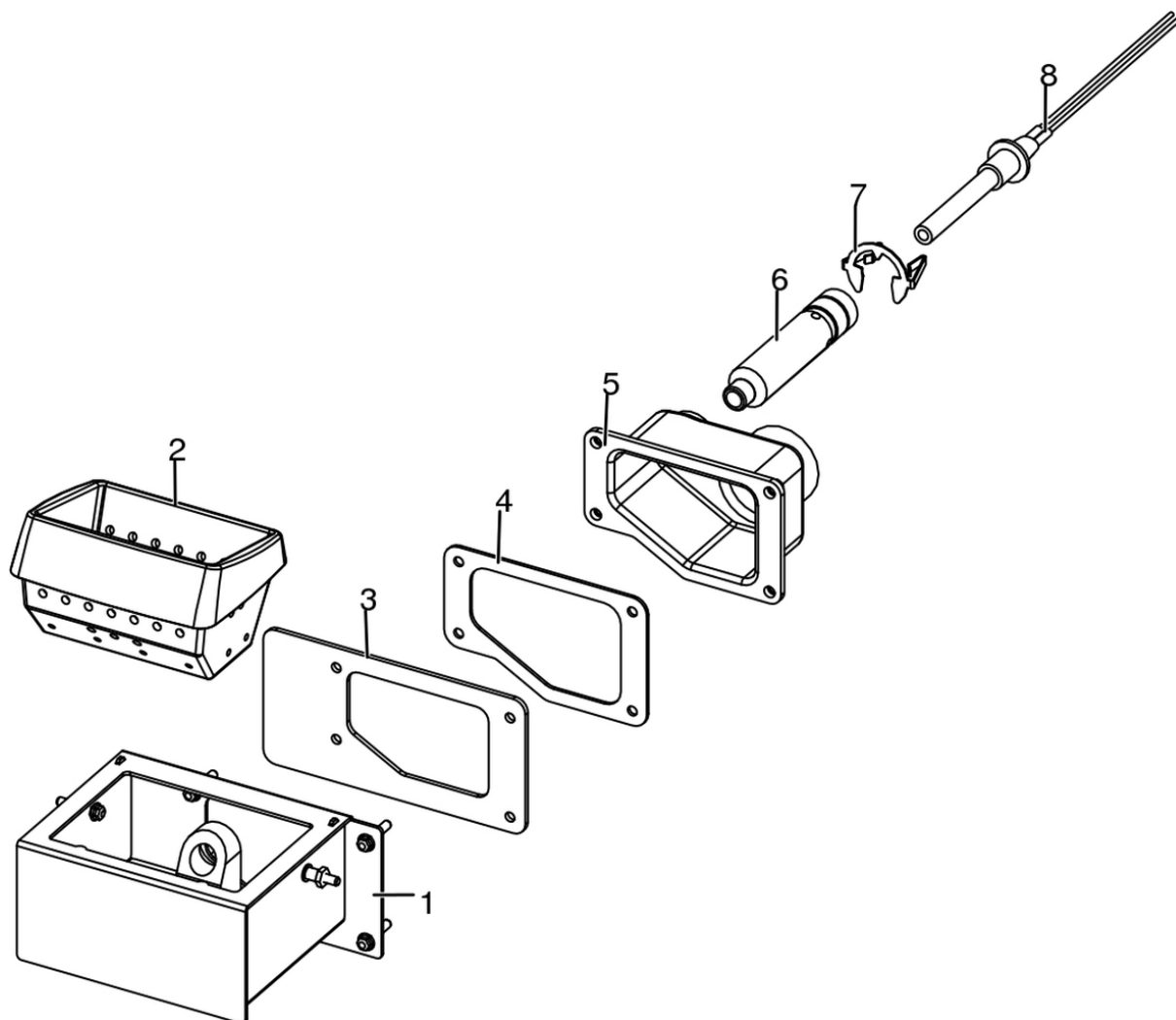

N°	Codice/Code	Descrizioni / Description / Beschreibung / Description / Descripción
1	41411613140V	Tasca braciere / Combustion pot container / Brenntopfkasten / Réciipient brasero / Contenedor brasero
2	41301502400V	Braciere ghisa / Cast iron grate / Brenntopf aus Gusseisen / Brasero en fonte / Brasero en arrabio
3	41801601500	Guarnizione tasca braciere / Combustion pot container gasket / Brenntopfkasten Dichtung / Joint réciipient brasero / Junta contenedor brasero
4	41801602300	Guarnizionaio codolo / Gasket / Dichtung / Joint / Junta
5	41311600100	Codolo / Tool chuck / Einspannschaft / Outil d'emmanchement / Mango
6	41601601000	Condotto candeletta / Sparkplug Conduit / Zündkerzenkanal / Conduit Bougie / Conducto Bujía
7	41201601500	Anello arresto candeletta / Sparkplug stop / Zündkerzestopper / Butée bougie / Tope bujía
8	41451308101	Candeletta 315 Watt / Sparkplug 315 Watt / Zündkerze 315 Watt / Bougie 315 Watt / Bujía 315 Watt
8	41451308150	Kit 25 candelette 315 Watt / 25 Sparkplugs 315 Watt kit / Bausatz 25 Zündkerzen 315 Watt / Kit 25 Bougies 315 Watt / Kit 25 Bujías 315 Watt

BERG MAESTRO

Porta fuoco in lamiera / Metal sheet fireplace door / Blechfeuertür / Porte foyer en tôle / Puerta hogar de chapa

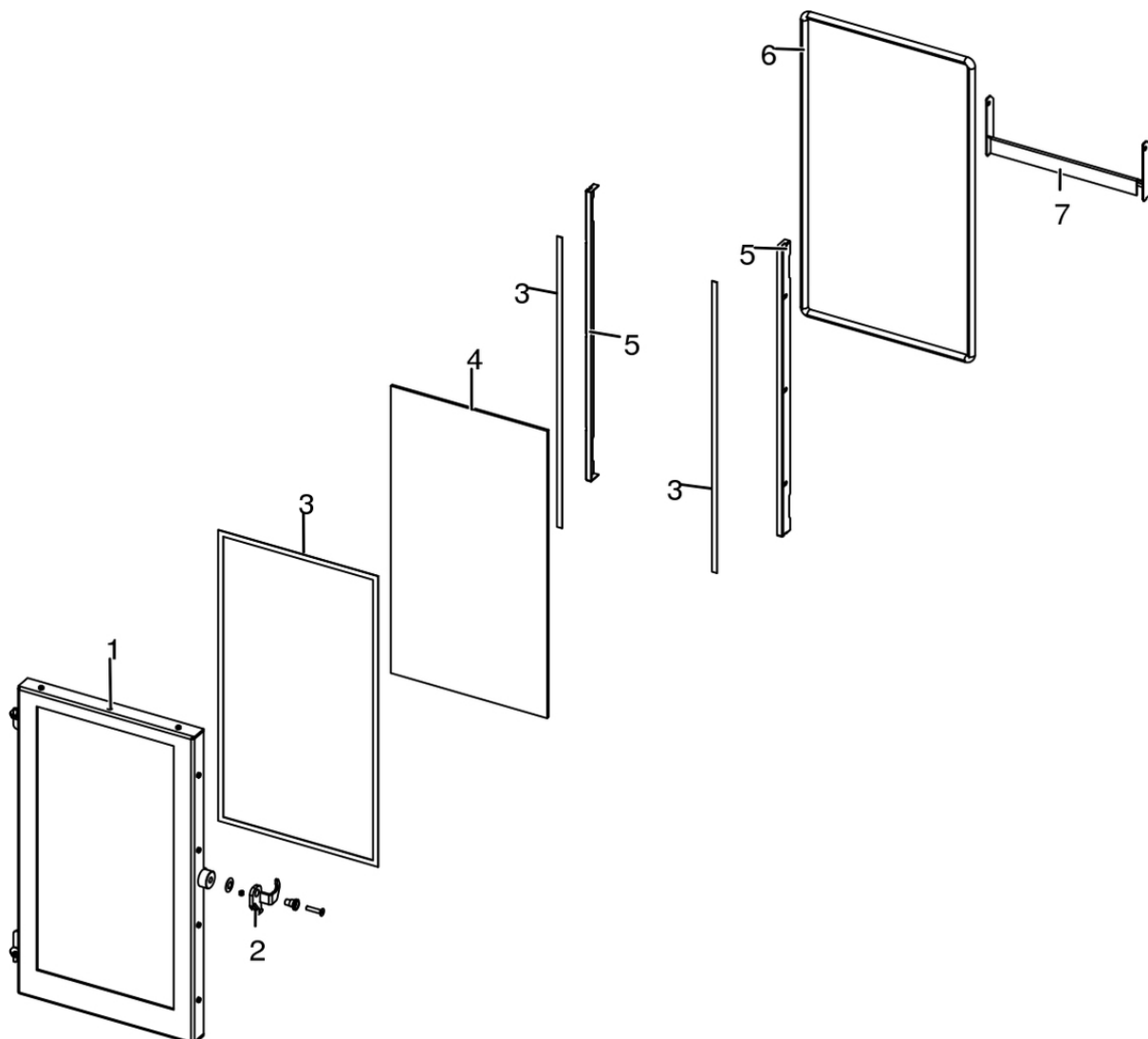

N°	Codice/Code	Descrizioni / Description / Beschreibung / Description / Descripcion
1	41421600941V	Telaio porta fuoco / Fire door frame / Feuertürrahmen / Cadre porte foyer / Armazón puerta de arrabio
2	41411616560	Maniglia porta nera / Door Handle / Türgriff / Poignée porte / Tirador
3	4120573A	Guarnizione a nastro 8 mm (5 mt.) per porta / Door strip gasket 8 mm (5 m) / Türbanddichtung 8 mm (5 m) / Joint ruban 8 mm (5 m) pour porte / Guarnición de cinta para puerta 8 mm (5 m)
3	4120573B	Guarnizione a nastro 8 mm (50 mt.) per porta / Door strip gasket 8 mm (50 m) / Türbanddichtung 8 mm (50 m) / Joint ruban 8 mm (50 m) pour porte / Guarnición de cinta para puerta 8 mm (50 m)
4	41701600200	Vetroceramico / Glass / Glaskeramikscheibe / Vitrocéramique / Cristal cerámico
5	41401610630	Fermavetro destro/sinistro Porta / Right/Left glass fastening bracket door / Rechte/Linke Haltebügel für Tür / Droit/Gauche etrier de fixation vitrocéramique - porte / Retendor derecho/izquierdo del cristal - puerta
6	4120104A	Cordino fibroceramico Ø 12 mm (5 mt.) / Ceramic fibre cord Ø 12 mm (5 m.) / Keramikfaserschnur Ø 12 mm (5 m) / Cordon en fibre céramique Ø 12 mm (5 m) / Junta a cuerda de fibra cerámica Ø 12 mm (5 m)
6	4120104B	Cordino fibroceramico Ø 12 mm (50 mt.) / Ceramic fibre cord Ø 12 mm (50 m.) / Keramikfaserschnur Ø 12 mm (50 m) / Cordon en fibre céramique Ø 12 mm (50 m) / Junta a cuerda de fibra cerámica Ø 10 mm (52 m)
6	41201041	Kit sostituzione cordino (cordino+silicone) Ø 12 mm / Cord replacement kit (cord + silicon) Ø 12 mm / Schnuraustauschsatz (Schnur+Silikon) Ø 12 mm / Kit remplacement cordon (cordon + silicone) Ø 12 mm / Kit sustitución junta a cuerda (junta a cuerda+silicón) Ø 12 mm
7	41411616430V	Deflettore inferiore porta nero / Lower black door deflector / Unterer schwarze Leitblech der Tür / Deflecteur inférieur noir de la porte / Deflector negro inferior de la puerta

BERG MAESTRO

Gruppo aria comburente / Combustion air group / Verbrennungsluft Gruppe / Groupe air comburant / Grupo aire comburente

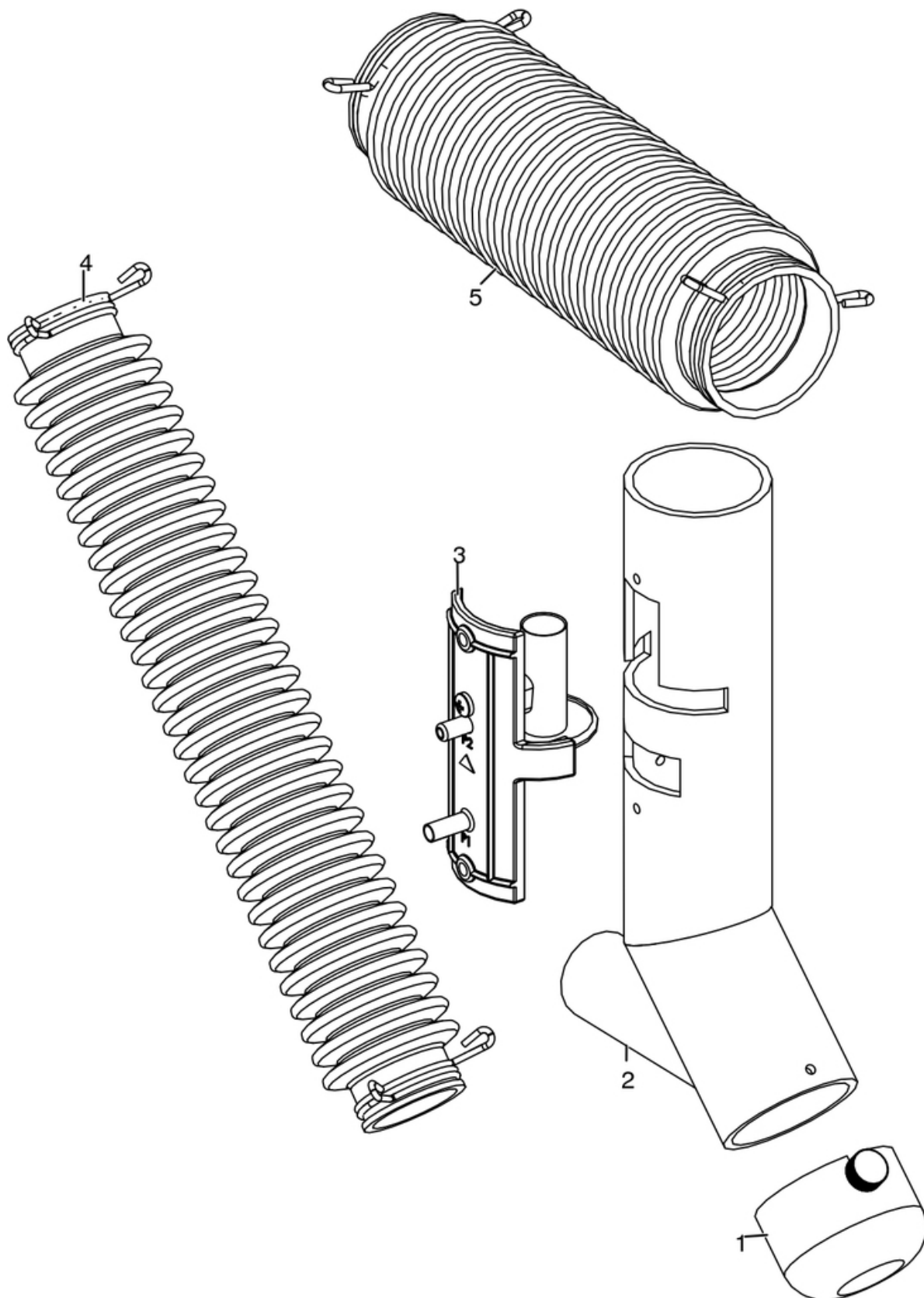

N°	Codice/Code	Descrizioni / Description / Beschreibung / Description / Descripción
1	41401036100	Filtro antipolvere / Anti-dust filter / Staubschutzfilter / Filtre antipoussière / Filtro de protección polvo
2	41601601800V	Tubo aspirazione nero / Black air inlet pipe / Schwarz Lufteingangrohr / Tuyau entrée d'air noir / Tubo entrada aire negro
3	41601301850	Componente rilevamento portata aria / Air flow measure component / Bauteil für Messung der Luftmenge / Composent pour la mesuration de la quantité d'air / Componente por la medida de l'aire
4	41801601900	Tubo aspirazione pulizia vetro / Inlet pipe for cleaning glass air / Glasreinigung Lufteingangrohr / Tuyau entrée pour l'aire de nettoyage du vitre / Tubo entrada por l'aire de limpieza vidrio
5	41801601700	Tubo aspirazione camera combustione / Combustion chamber aspiration tube / Verbrennungskammer Förderrohr / Tuyau aspiration air chambre de combustion / Tubo aspiración aire cámara de combustión

BERG MAESTRO

Gruppo elettrico ed elettronico / Electrical and electronic group / Elektrische und elektronische Gruppe / Groupe électrique et électronique / Grupo eléctrico y electrónico

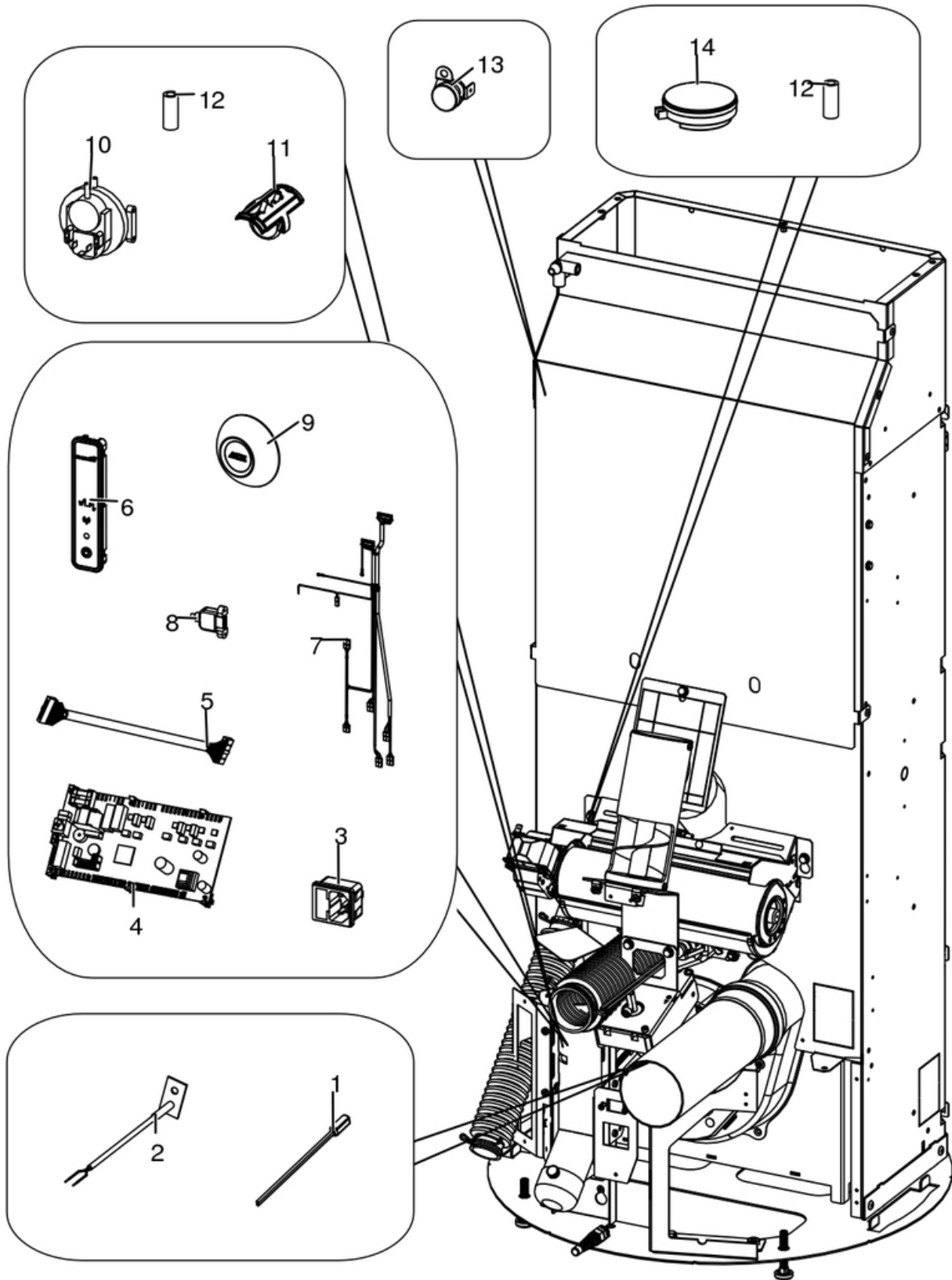

N°	Codice/Code	Descrizioni / Description / Beschreibung / Description / Descripción
1	4160386	Sonda temperatura ambiente/acqua / Room/Water temperature sensor / Raum- Wassertemperaturfühler / Sonde température ambiance/eau / Sonda temperatura ambiente/agua
2	41451703600	Sonda fumi con flangia con morsettiera L.980 / Smoke sensor with flange with terminal board L.980 / Rauchsonde mit Flansche mit Klemmenbrett L.980 / Sonde fumées avec bride avec serre-câble L.980 / Sonda humos con brida con borne L.980
3	4160193	Pulsante accensione / On/Off button / Zündungstaste / Touche d'allumage / Botón encendido
4	41451602602	Scheda elettronica plus / Electronix mother board plus / Elektronische Platine Plus / Carte mère électronique plus / Tarjeta madre electronica plus
5	41451801600	Cavo flat 20 vie L.600 mm / Flat cable 20 pin L.600 mm / Flat-Kabel 20polig L.600 mm / Cable flat 20 voies L.600 mm / Flat cable 20 vias L.600 mm
6	41451602802	Pannello di emergenza Wireless / Wireless emergency display / Wireless Notfall-Blende / Panneau d'urgence wireless / Panel emergencia wireless
7	41451603701	Cablaggio elettrico base maestro / Basic electrical wiring maestro / Elektrische Verkabelung Maestro / Câblage électrique Maestro / Cableado eléctrico Maestro
7	41451803550	Kit cablaggi messa a terra / Grounding wiring kit / Erdungskabelbaum / Kit mise à terre / Kit cableado a tierra
8	41451403200	Cavo USB da pannello L.500 / USB Cable from display L.500 / USB Kabel von Notfalldisplay L.500 / Câble USB de panneau L.500 / Cable USB del panel L.500
9	4020006	Telecomando / Remote control / Fernbedienung / Télécommande / Mando a distancia
9	4017014	Sensore temperatura Wireless / temperature sensor Wireless / Temperaturfühler Wireless / Capteur de Temperatur Wireles / Sensor de temperatura Wireless
10	41451003700	Pressostato / Pressure switch / Druckschalter / Pressostat / Presostato
11	41601301850	Componente rilevamento portata aria / Air flow measure component / Bauteil für Messung der Luftmenge / Composent pour la mesuration de la quantité d'air / Componente por la medida de l'aire
12	4120631A	Tubicino siliconico - 5m / Silicon tube - 5m / Silikonrohr - 5m / Petit tuyau en silicone - 5m / Tubo silicónico - 5m
13	412007004	Clickson 110°C / Clickson 110°C / Clickson 110°C / Clickson 110°C / Clickson 110°C
14	41451303400	Trasduttore di pressione / Pressure transducer / Active-Wandler / Transducteur de pression / Transductor de pression

BERG MAESTRO

Gruppo fumi / Smoke group / Rauchgruppe / Groupe fumées / Grupo de humos

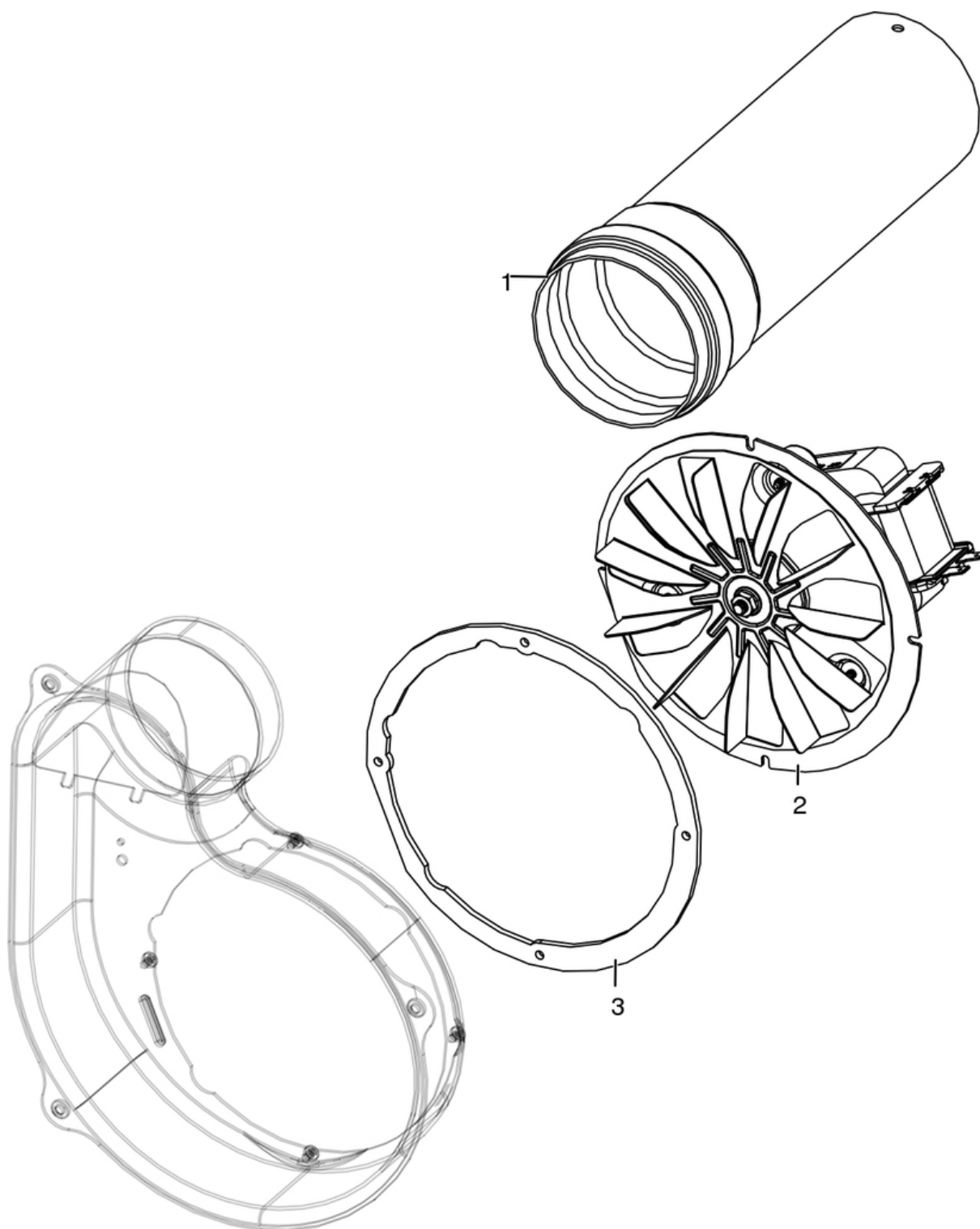

N°	Codice/Code	Descrizioni / Description / Beschreibung / Description / Descripcion
1	41601603000	Tubo Ø8 L.25 con guarnizione / Pipe Ø8 L.25 with gasket / Rohr Ø8 L.14 mit Dichtung / Tuyau Ø8 L.25 avec joint / Tubo Ø8 L.25 con guarnición
2	41451503200	Ventilatore fumi stagno / Air-tight smoke exhausted fan / Luftdichtes Rauchgasgebläse / Ventilateur fumées étanche / Ventilador humos hermético
2	41451703000	Encoder per ventilatore fumi marchio EBM / Encoder for EMB smoke fan / Encoder für EBM Rauchgasgebläse /

		Encoder pour ventilateur des fumées marque EBM / Encoder para ventilador humos marca EBM
2	41451209300	Encoder per ventilatore fumi marchi LN2/SIT / Encoder for LN2/SIT smoke fan / Encoder für LN2/SIT Rauchgasgebläse / Encoder pour ventilateur des fumées marques LN2/SIT / Encoder para ventilador humos marcas LN2/SIT
2	41452009200	Encoder ventilatore / Fan encoder / Lüfter Encoder / Encodeur de ventilateur / Codificador de ventilador
3	41801600800	Guarnizione ventilatore fumi / Smoke exhaust fan gasket / Dichtung Rauchabsauggebläse / Joint Ventilateur aspiration fumées / Junta ventilador aspiración humos

BERG MAESTRO

Gruppo ventilazione / Ventilation group / Lüftungsgruppe / Groupe de ventilation / Grupo de ventilación

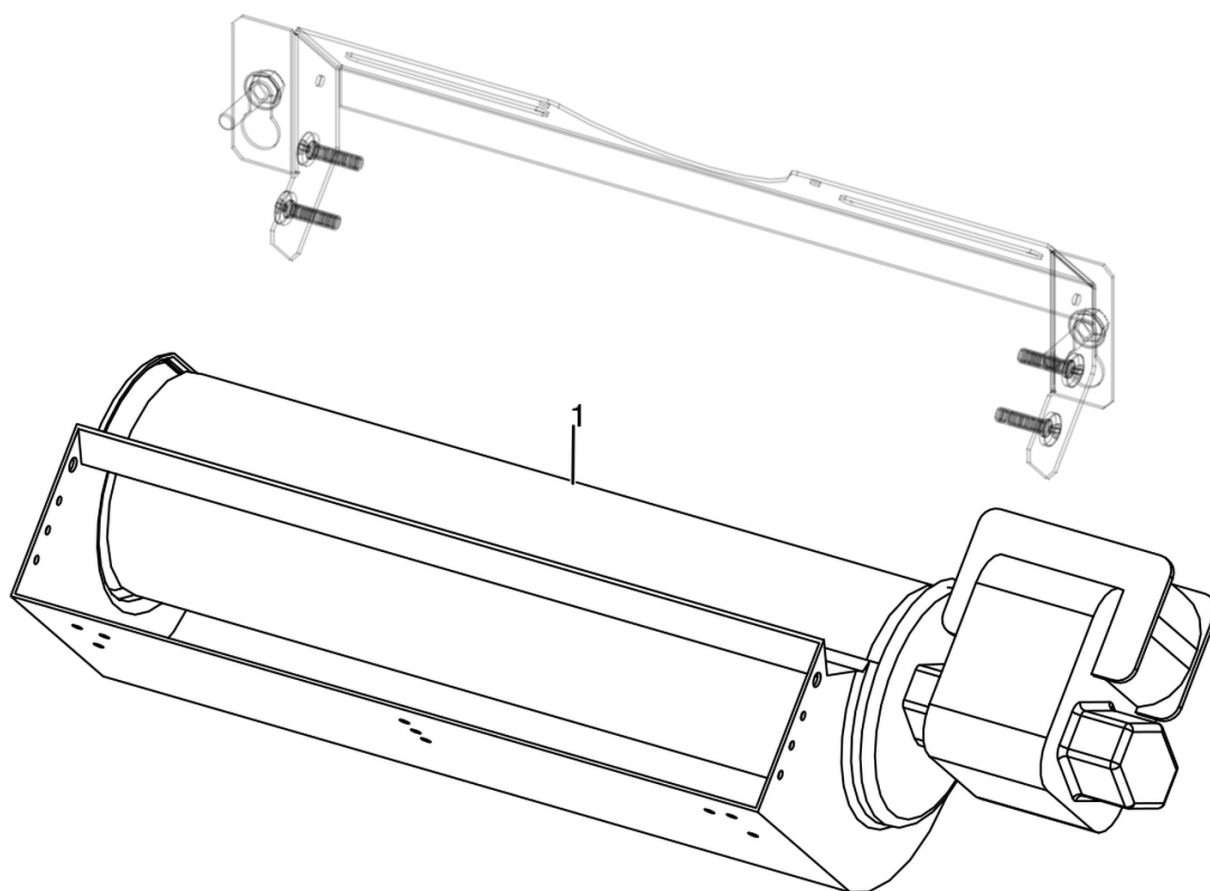

N°	Codice/Code	Descrizioni / Description / Beschreibung / Description / Descripción
1	41451600800	Ventilatore aria / Air fan / Luftgebläse / Ventilateur air / Ventilador aire

BERG MAESTRO

Gruppo estetico / Aesthetic group / Aesthetische Gruppe / Groupe esthétique / Grupo estético

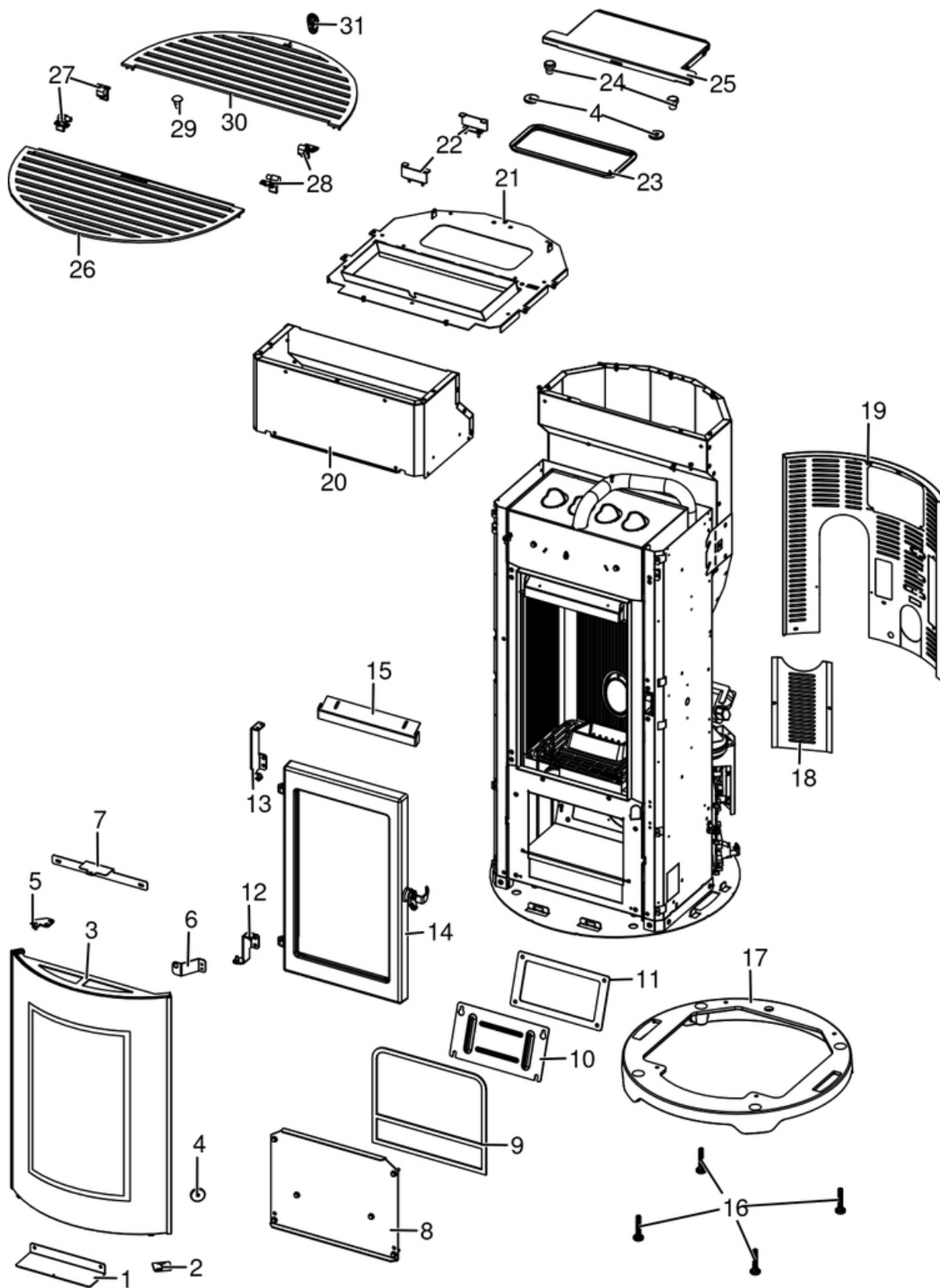

N°	Codice/Code	Descrizioni / Description / Beschreibung / Description / Description
----	-------------	--

1	41411614630V	Supporto frontale inferiore / Lower panel support / Untere Vordere Gestell / Support panneau frontal inferieur / Soporte panel frontal inferior
2	41411658860	Maniglia porta esterna / External door handle / Außentür Griff / Poignée porte extérieur / Tirador puerta exterior
3	437016142	Porta estetica / Aesthetic door / Ästhetische Tür / Porte esthétique / Puerta estética
4	41801657900	Magneti (pz.2) / Magnet (pcs.2) / Magnet (stk. 2) / Aimant (pcs.2) / Imán (pz.2)
5	41411614940V	Blocco cerniera superiore / Upper hinge stop / Obere Scharnierstopper / Stop charnière supérieure / Tope bisagra superior
6	41411663030V	Staffa appoggio porta / Door support bracket / Haltebügel der tür / Étrier support porte / Abrazadera de soporte puerta
7	41411614630V	Supporto frontale inferiore / Lower panel support / Untere Vordere Gestell / Support panneau frontal inferieur / Soporte panel frontal inferior
8	437016050	Tappo inferiore / Lower cover / Untere Abdeckung / Couvercle inférieur / Tapón inferior
9	4120573A	Guarnizione a nastro 8 mm (5 mt.) per porta / Door strip gasket 8 mm (5 m) / Türbanddichtung 8 mm (5 m) / Joint ruban 8 mm (5 m) pour porte / Guarnición de cinta para puerta 8 mm (5 m)
9	4120573B	Guarnizione a nastro 8 mm (50 mt.) per porta / Door strip gasket 8 mm (50 m) / Türbanddichtung 8 mm (50 m) / Joint ruban 8 mm (50 m) pour porte / Guarnición de cinta para puerta 8 mm (50 m)
10	41401339610	Tappo ispezione vano fumi / Smoke compartment inspection plug / Inspektionsdeckel Rauchabzug / Clapet inspection compartiment fumées / Tapón inspección compartimento humos
11	41800900600	Guarnizione / Gasket / Dichtung / Joint / Junta
11	41801599750	Kit 50 guarnizioni / Kit 50 gaskets / Bausatz 50 Dichtungen / Kit 50 joints / Kit 50 juntas
12	41411730740V	Cerniera inf.porta ghisa / Lower hinge for cast iron door / Unterer Scharnier für Tür aus Guß / Charnière inférieure pour porte en fonte / Bisagra inferior por porta en arrabio
12	41411614740V	Cerniera inferiore nera / Black lower hinge / Schwarzes unteres Scharnier / Charnière inférieure noire / Bisagra inferior negra
13	41411730840V	Cerniera superiore / Upper hinge / Oberes Scharnier / Charnière supérieure / Bisagra superior
13	41411614830V	Cerniera superiore sera / Black upper hinge / Schwarzes oberes Scharnier / Charnière supérieure noire / Bisagra superior negra
14	437017082	Porta fuoco in ghisa / Cast iron fireplace door / Feuertür aus Gusseisen / Porte foyer en fonte / Puerta hogar de arrabio
14	437016055	Porta focolare in lamiera / Metal sheet fire door / Feuerstelle Tür / Porte foyer / Puerta hogar
15	41411615430V	Deflettore aria / Air deflector / Luftleitblech / Déflecteur aire / Deflector aire
16	41200906660	Piedini di appoggio (4 pz.) / Support feet (4 pcs.) / Einstellfüße (4 Stck.) / Vérins d'appui (4 p.es) / Pies de apoyo (4 piezas)
17	41301600900P	Basamento in ghisa / Cast iron base / Basis auf gussseisen / Base en fonte / Base de arrabio
18	41411624230P	Flangia pannello ispezione nera / Inspection panel black flange / Inspektionklappe Schwarzflansch / Bride noir trappe inspection / Brida negra tapa inspección
19	4140183193000	Schiene esterna / External back / Externe Rückseite / Dos externe / Parte trasera esterna
19	4140172540000	Carter motoriduttore / Crankcase for geared motor / Kurbelgehäuse für Getriebemotor / Carter pour le motoréducteur / Carter para motorreductor
20	41411624150	Convogliatore aria / Air conveyor / Luftblech / Convoyeur air / Conductor del aire
21	41411614240V	Supporto top completo / Top support / Deckelhaltebügel / Support du dessus / Soporte top
22	41411625030V	Supporto top / Top support / Deckelhaltebügel / Support du dessus / Soporte del top
23	41801601400	Guarnizione coperchio serbatoio / Pellet hopper cover gasket / Deckel Pelletbehälter Dichtung / Joint couvercle réservoir pellet / Junta tapa depósito pellet
24	4120180	Gommini paracolpi (4 pz) / Rubber bumpers (4 pcs.) / Schlagschutzgummi (4 Stck) / Pièces caoutchouc antichoc (4 pcs) / Cauchitos anti-golpes (4 pz)
25	437016053	Coperchio serbatoio / Hopper cover / Deckel Pelletbehälter / Couvercle réservoir / Tapa depósito
26	41411624340P	Top fisso nero / Top / Abdeckplatte / Dessous / Top
27	41411624930P	Staffa SX / L. Bracket / Li. Bügel / Étrier G. / Abrazadera IZDA
28	41411624830P	Staffa DX / R. Bracket / RE. Bügel / Étrier D. / Abrazadera DCHA
29	41801002300	Paracolpi in silicone Ø 8/5 (2pz) / Silicone bumpers Ø 8/5 (2pcs) / Schlagschutzgummi Ø 8/5 (2 Stck) / Pièces silicone antichoc Ø 8/5 (2pcs) / Anti-golpes en silicona Ø 8/5 (2pzs)
30	41411624640P	Top mobile nero / Black amovable top / Schwarze abnehmbares Deckel / TOP noir démontable / Top negroamovible
31	41801602200	Maniglia silconica / silicone handle / Silikongriff / Poignée de silicone / Tirador de silicona