

## CUTE AIR 8 M1

Gruppo estetico / Aesthetic group / Aesthetische Gruppe / Groupe esthétique / Grupo estético

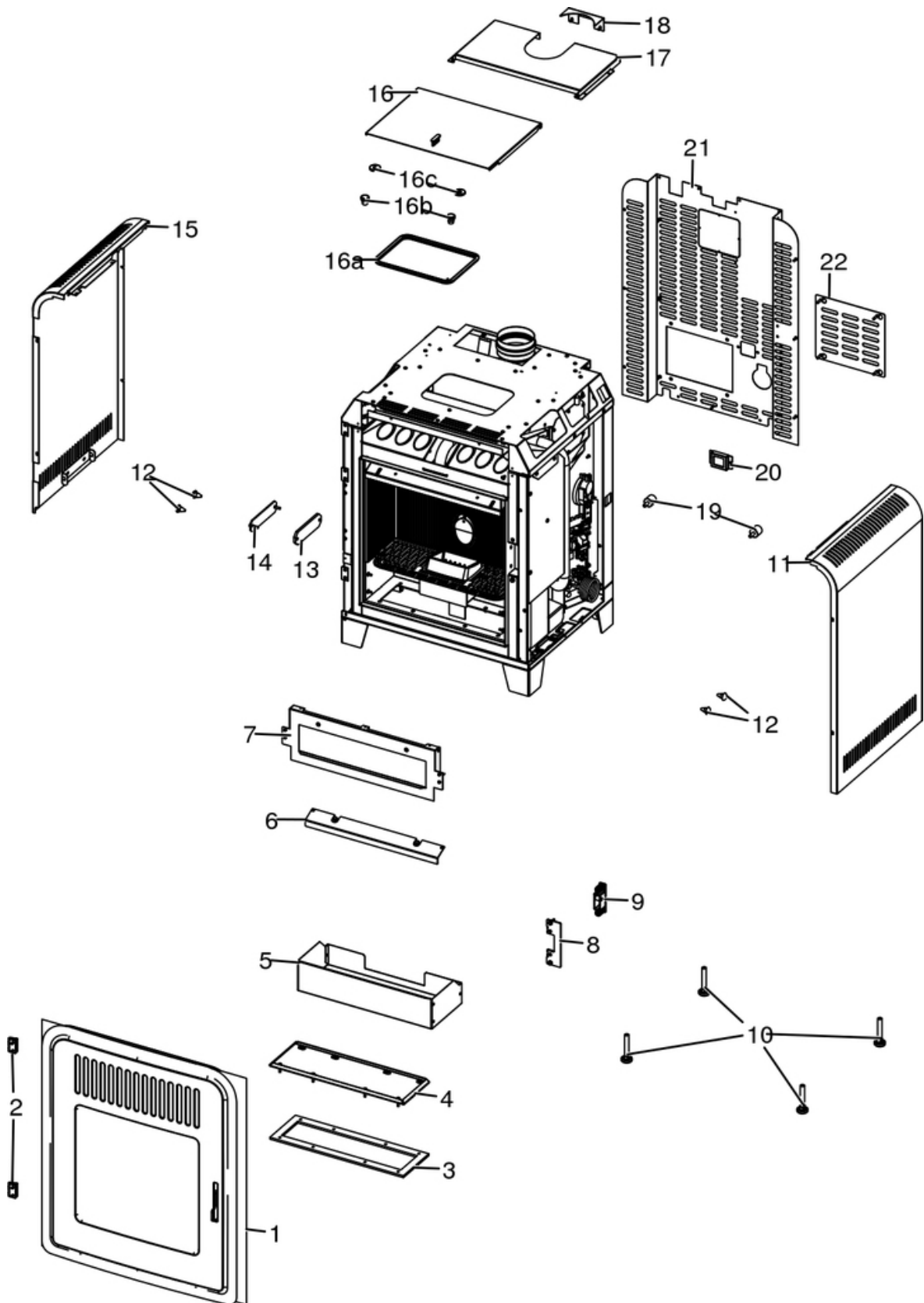

N°	Codice/Code	Descrizioni / Description / Beschreibung / Description / Descripción
1	437019095	Porta ghisa completa / Cast iron complete door / Komplette Tür aus Güsseisen / Porte en fonte complète / Puerta completa de arrabio
2	41201216401	Cerniera / Door anchoring / Federscharnier / Charnière / Bisagra
3	41801902200	Guarnizione tappo focolare / Gasket for combustion chamber cover / Dichtung Feuerraum Verschluss / Joint clapet foyer / Junta tapa hogar
4	41401908230	Tappo camera fumi / Smoke compartment plug / Rauchabzugklappe / Couvercle compartiment fumées / Tapón compartimento humos
5	41401908130	Cassetto cenere / Ash drawer / Aschenkasten / Tiroir à cendres / Cajón ceniza
6	4141192044000	Deflettore pulizia vetro / Deflector for glass cleaning / Leitblech für Glassreinigung / Deflecteur pour nettoyage du verre / Deflector por limpieza vidrio
7	4141192443000	Convogliatore / Air duct / Förder / Convoyeur / Conductor
8	4141192213000	Staffa / Bracket / Bügel / Etrier / Abrazadera
9	41411599950	Kit serratura ammortizzato / Pressur relief kit / Bausatz Überdruckablauf Brennkammer / Kit deocompression chambre comcusion / Kit decompression cámara combustion
10	41201600160	Piedino zincato nero / Galvanized foot / Verzinktes Fus / Vérin zingué / Pie galvanizado
11	4141192424000	Fianco destro / Right side / Rechte Seite / Coté droite / Lateral derecho
12	41801002300	Paracolpi in silicone Ø 8/5 (2pz) / Silicone bumpers Ø 8/5 (2pcs) / Schlagschutzgummi Ø 8/5 (2 Stck) / Pièces silicone antichoc Ø 8/5 (2pcs) / Anti-golpes en silicona Ø 8/5 (2pzs)
13	41801400900	Guarnizione / Gasket / Dichtung / Joint / Junta
14	4141191951000	Tappo ispezione / Inspection plug / Inspektionskappe / Clapet inspection / Tapón inspección
15	4141192414000	Fianco sinistro / Left side / Linke Seite / Coté gauche / Lateral izquierdo
16	4141192304000	Coperchio / Cover / Deckel / Couvercle / Tapa
16a	41801504700	Guarnizione tenuta serbatoio / Pellet hopper gasket / Pelletbehälter Dichtung / Joint réservoir pellet / Junta depósito pellet
16b	4120180	Gommini paracolpi (4 pz) / Rubber bumpers (4 pcs.) / Schlagschutzgummi (4 Stck) / Pièces caoutchouc antichoc (4 pcs) / Cauchitos anti-golpes (4 pz)
16c	41801657900	Magneti (pz.2) / Magnet (pcs.2) / Magnet (stk. 2) / Aimant (pcs.2) / Imán (pz.2)
17	4141192323000	Top posteriore / Rear top / Hintere Abdeckplatte / Dessus postérieur / Top posterior
18	4141192333000	Tamponazione / Filling / Auffüllung / Tampon / Taponado
19	41201105600	Antivibranti (10 pz) / anti-vibration mountings (10 pcs) / Schwingungsdämpfer (10 Stck) / Éléments antivibratoires (10 pcs) / Anti-vibraciones (10 pz)
20	41401908630	Supporto presa / Electrical outlet support / Steckdose Halterung / Support prise électrique / Soporte toma de corriente eléctrica
21	4141192433000	Schiena / Rear back / Rückwand / Dos / Espalda
22	41401904310	Tappo schiena / Rear back stopper / Rückwandverschluss / Bouchon de dos / Tapa de la espalda

## CUTE AIR 8 M1

Gruppo camera di combustione / Combustion chamber group / Verbrennungskammer Gruppe / Group de chambre de combustion / Grupo cámara de combustión

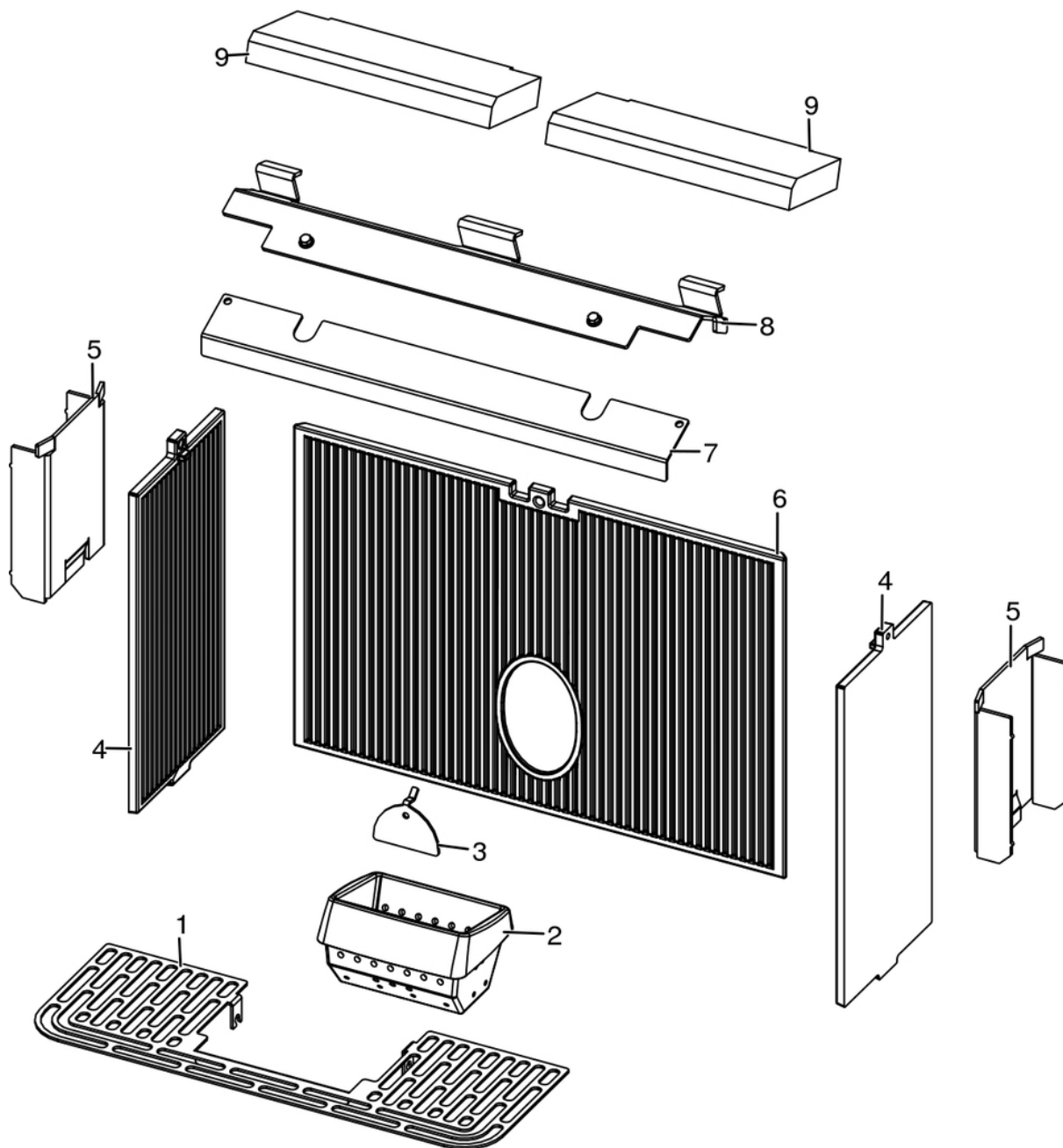

N°	Codice/Code	Descrizioni / Description / Beschreibung / Description / Descripción
1	4141192063000	Griglia / Grille / Rost / Grille / Rejilla
2	41301502400V	Braciere ghisa / Cast iron grate / Brenntopf aus Gusseisen / Brasero en fonte / Brasero en arrabio
3	41411613530V	Deffettore pellet / Pellet deflector / Pellet Leitblech / Deflecteur pellet / Deflector pellet
4	4130190120000	Fianco ghisa nero / Black cast iron side / Schwarze Seite aus Gusseisen / Coté noir en fonte / Placa lateral de arrabio negra
5	41411919831	Tappo focolare / Combustion chamber plug / Feuerraum Verschluss / Clapet foyer / Tapón hogar
6	4130190110000	Schiena ghisa nera / Cast iron back / Rückwand aus Gusseisen / Dossieret en fonte / Parte trasera en arrabio
7	4141192044000	Deffettore pulizia vetro / Deflector for glass cleaning / Leitblech für Glassreinigung / Deflecteur pour nettoyage du verre / Deflector por limpieza vidrio
8	41331902130	Staffa bloccaggio vermiculite / Vermiculite blocking bracket / Haltebügel für Vermiculite / Étrier blocage vermiculite / Abrazadera bloqueo vermiculite

9	41151900100	Deflettore focolare in vermiculite / Vermiculite deflector / Leitblech aus Vermiculite / Déflecteur en vermiculite / Deflector en vermiculite
---	-------------	---

## CUTE AIR 8 M1

Porta fuoco / Fire door / Feuertür / Porte foyer / Puerta hogar

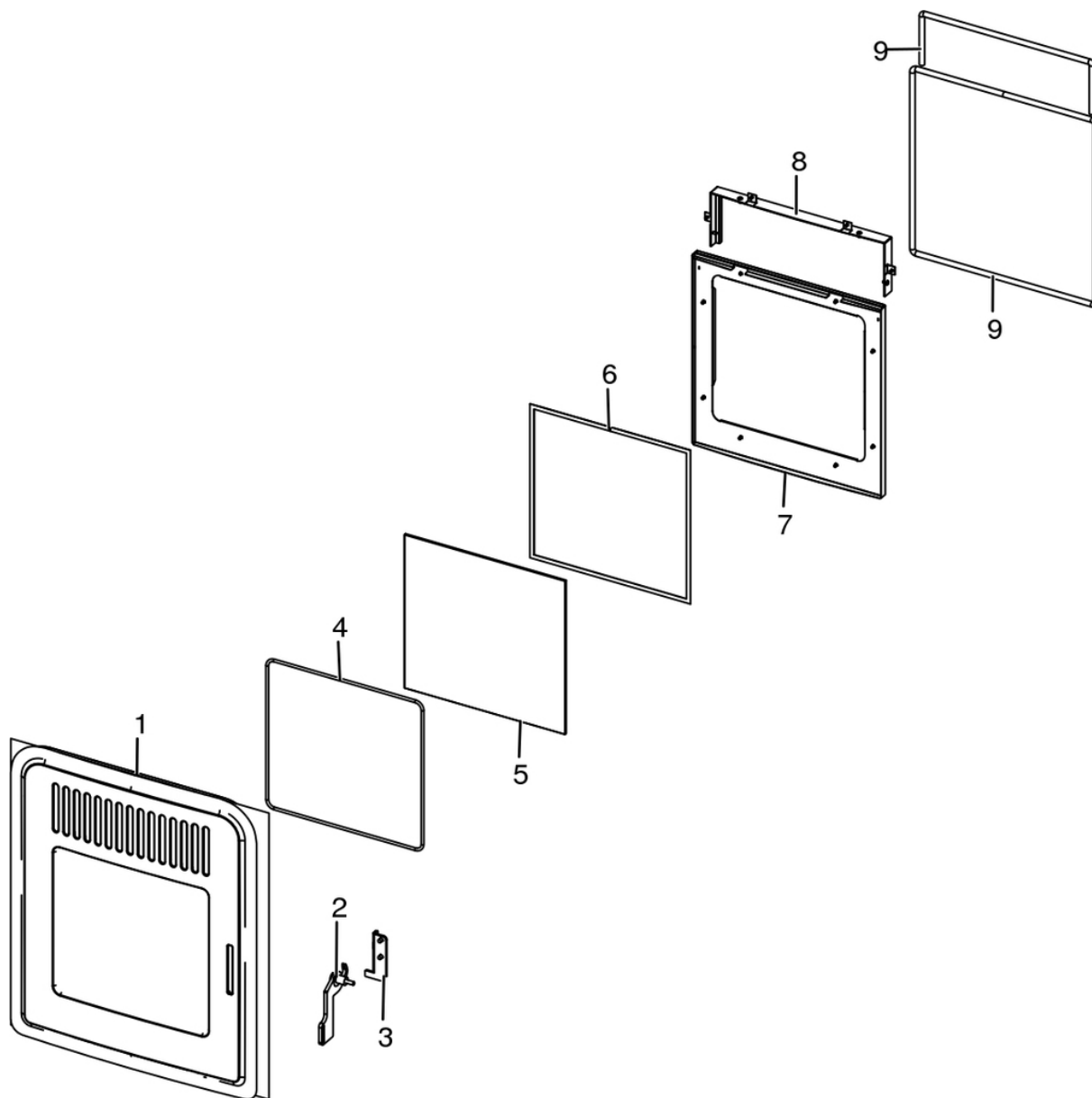

N°	Codice/Code	Descrizioni / Description / Beschreibung / Description / Description
1	4130120070100	Porta in ghisa / Cast iron door / Tür aus Gusseisen / Porte en fonte / Puerta de arrabio
2	41401336760	Maniglia completa / Complete handle / Kompletter Griff / Poignée complète / Tirador completo
3	4140133654100	Supporto maniglia / Handle support / Griffhalterung / Support poignée / Soporte manija
4	41201801000A	Cordino fibroceramico Ø 6 mm (5 m.) / Ceramic fibre cord Ø 6 mm (5 m.) / Keramikfaserschnur Ø 6 mm (5 m.) / Cordon en fibre céramique Ø 6 mm (5 m.) / Junta a cuerda de fibra cerámica Ø 6 mm (5 m)
4	41201801000B	Cordino fibroceramico Ø 6 mm (50 m.) / Ceramic fibre cord Ø 6 mm (50 m.) / Keramikfaserschnur Ø 6 mm (50 m.) / Cordon en fibre céramique Ø 6 mm (50 m.) / Junta a cuerda de fibra cerámica Ø 6 mm (50 m)
4	41201801000C	Cordino fibroceramico Ø 6 mm + silicone (2,5 m.) / Ceramic fibre cord Ø 6 mm + silicon (2,5 m.) / Keramikfaserschnur Ø 6 mm + Silikon (2,5 m.) / Cordon en fibre céramique Ø 6 mm + silicón (2,5 m.) / Junta a cuerda de fibra cerámica Ø 6 mm + silicón (2,5 m)
5	41701201860	Vetroceramico / Glass / Glaskeramikscheibe / Vitrocéramique / Cristal cerámico
6	4120573A	Guarnizione a nastro 8 mm (5 mt.) per porta / Door strip gasket 8 mm (5 m) / Türbanddichtung 8 mm (5 m) / Joint ruban 8 mm (5 m) pour porte / Guarnición de cinta para puerta 8 mm (5 m)
6	4120573B	Guarnizione a nastro 8 mm (50 mt.) per porta / Door strip gasket 8 mm (50 m) / Türbanddichtung 8 mm (50 m) / Joint ruban 8 mm (50 m) pour porte / Guarnición de cinta para puerta 8 mm (50 m)

<b>7</b>	<b>4141192384000</b>	Telaio porta / Door frame / Türrahmen / Cadre porte / Armazón puerta
<b>8</b>	<b>4141193393050</b>	Profilo esterno/interno / External/internal profile / Aussen-/Innenprofil / Profil extérieur/intérieur / Perfil externo/interno
<b>9</b>	<b>4120104A</b>	Cordino fibroceramico Ø 12 mm (5 mt.) / Ceramic fibre cord Ø 12 mm (5 m.) / Keramikfaserschnur Ø 12 mm (5 m) / Cordon en fibre céramique Ø 12 mm (5 m) / Junta a cuerda de fibra cerámica Ø 12 mm (5 m)
<b>9</b>	<b>4120104B</b>	Cordino fibroceramico Ø 12 mm (50 mt.) / Ceramic fibre cord Ø 12 mm (50 m.) / Keramikfaserschnur Ø 12 mm (50 m) / Cordon en fibre céramique Ø 12 mm (50 m) / Junta a cuerda de fibra cerámica Ø 10 mm (52 m)
<b>9</b>	<b>41201041</b>	Kit sostituzione cordino (cordino+silicone) Ø 12 mm / Cord replacement kit (cord + silicon) Ø 12 mm / Schnuraustauschsatz (Schnur+Silikon) Ø 12 mm / Kit remplacement cordon (cordon + silicone) Ø 12 mm / Kit sustitución junta a cuerda (junta a cuerda+silicón) Ø 12 mm

## CUTE AIR 8 M1

Gruppo caricamento pellet / Pellet feed group / Pellet Fördergruppe / Groupe chargement du pellet / Grupo de carga pellet

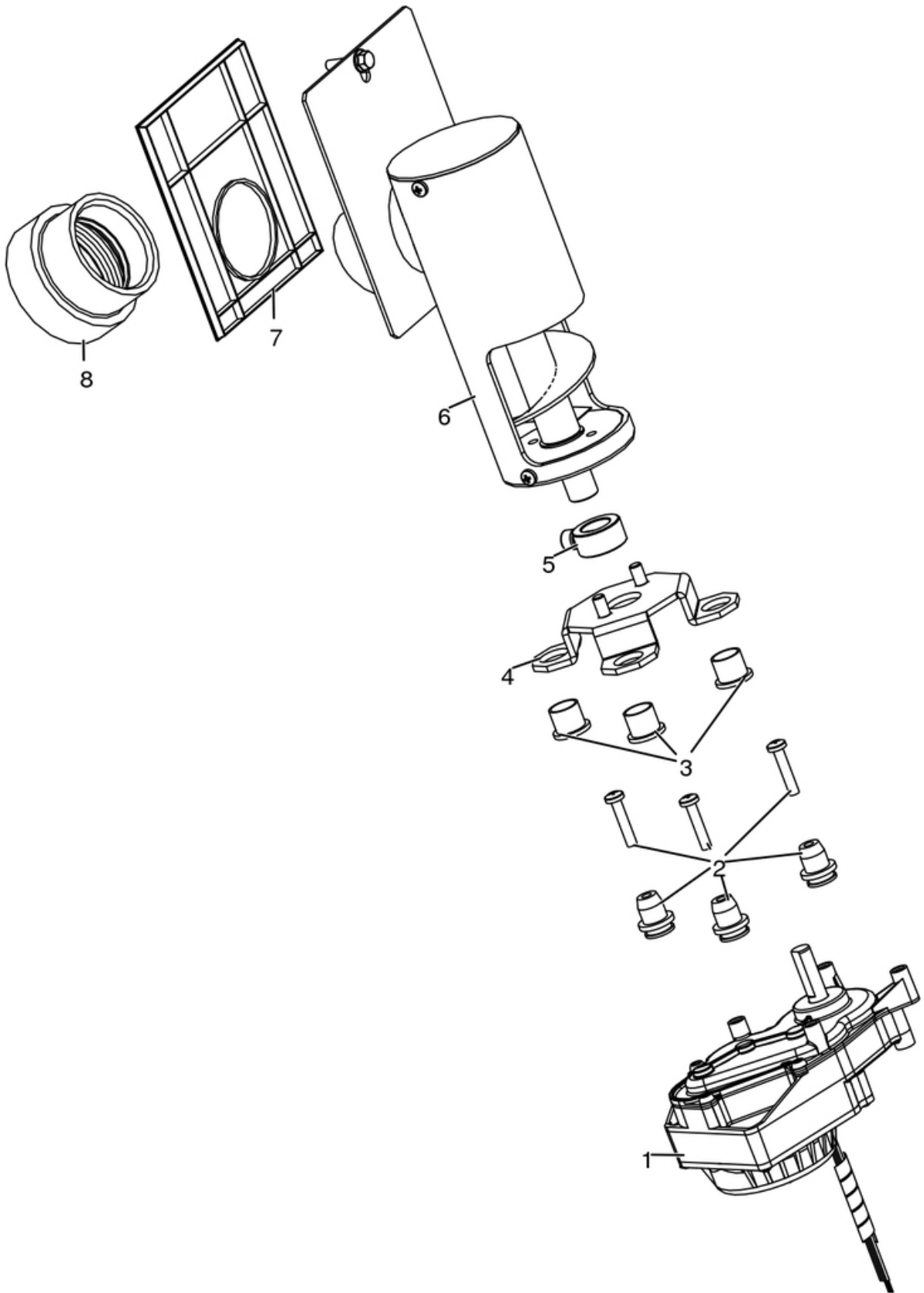

N°	Codice/Code	Descrizioni / Description / Beschreibung / Description / Descripción
1	41451702200	Motoriduttore brushless / Brushless reduction motor / Brushless Getriebemotor / Motoréducteur brushless / Motorreductor brushless
2	41801703700	Gommini antivibrante / Vibration damper rubber / Rammschutz Gummi / Caoutchouc antivibratoire / Cauchitos antivibración
3	41201800700	Boccola (3 pz) / Bushing (3 pcs) / Buchse (3 Stk) / Douille (3 pcs) / Abrazadera (3 pzs)
4	41411779331	Supporto coclea "Ragno" / Pellet feed screw bracket "spider" / "Spinne" Schenke Gestell / Support vis sans fin "Araignée" / Soporte coclea "Araña"
5	4120398	Connettore motoriduttore-coclea / Reduction motor-feed screw connector / Verbindung Getriebemotor-Schnecke / Connecteur motoréducteur-vis sans fin / Conector motorreductor-cóclea
6	437018060	Coclea caricamento pellet / Pellet feed screw / Pelletsförderschnecke / Vis Sans Fin Pour Chargement Pellet / Còclea De Carga Pellet
6	41411926940	Coclea caricamento pellet / Pellet feed screw / Pelletsförderschnecke / Vis Sans Fin Pour Chargement Pellet / Còclea De Carga Pellet
7	41801600400	Guarnizione gruppo caricamento / Gasket / Dichtung / Joint / Junta
8	41801702600	Disaccoppiatore mesc. Marrone / Brown disengaging device / Braun Verängungsrohr / Tuyau de découplage maron / Tubo de desvío marron



## CUTE AIR 8 M1

Gruppo elettrico ed elettronico / Electrical and electronic group / Elektrische und elektronische Gruppe / Groupe électrique et électronique / Grupo eléctrico y electrónico

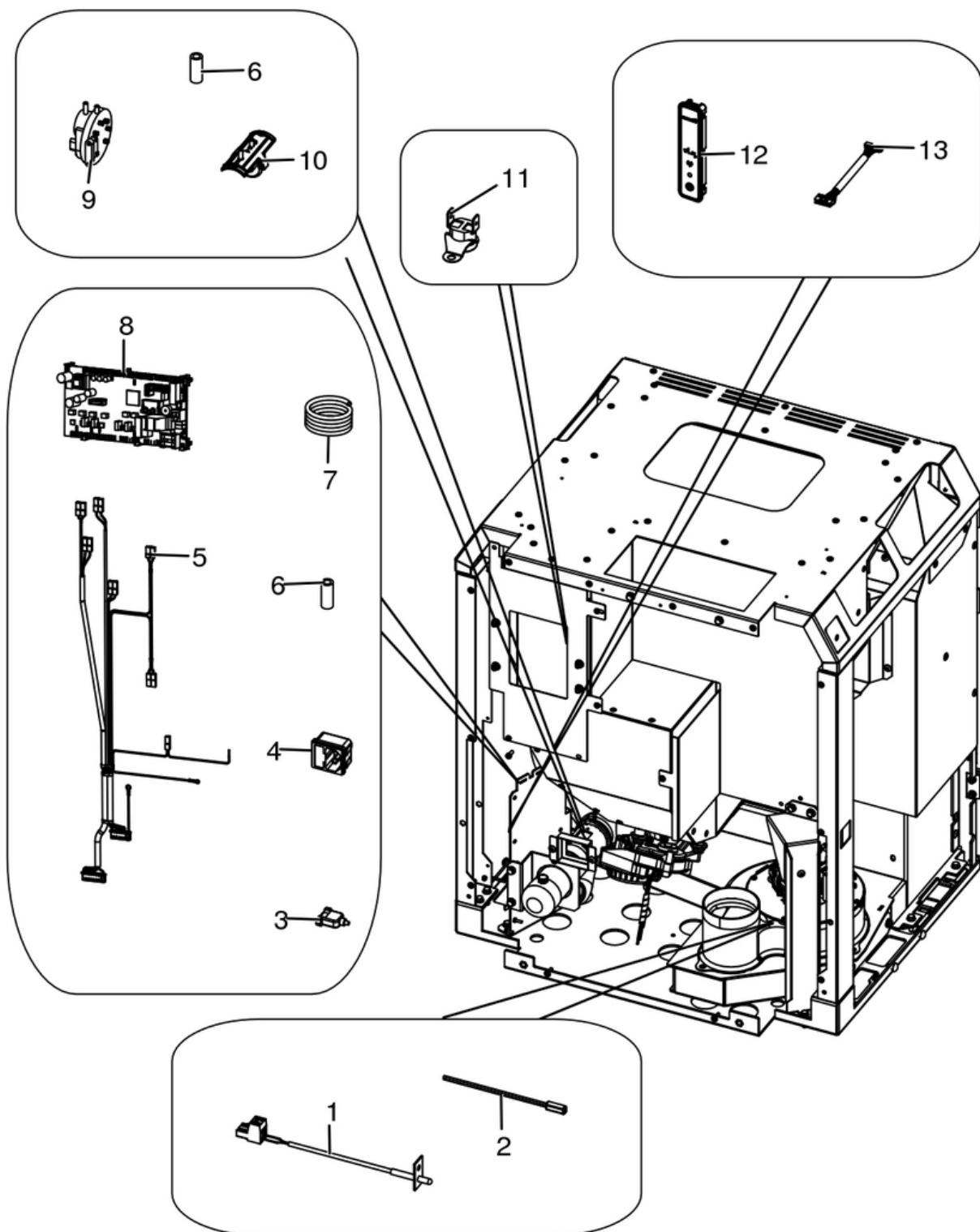

N°	Codice/Code	Descrizioni / Description / Beschreibung / Description / Description
1	41451703600	Sonda fumi con flangia con morsetti L.980 / Smoke sensor with flange with terminal board L.980 / Rauchsonde mit Flansche mit Klemmenbrett L.980 / Sonde fumées avec bride avec serre-câble L.980 / Sonda humos con brida con borne L.980
2	4160386	Sonda temperatura ambiente/acqua / Room/Water temperature sensor / Raum- Wassertemperaturfühler / Sonde température ambiance/eau / Sonda temperatura ambiente/agua

<b>3</b>	<b>41451403200</b>	Cavo USB da pannello L.500 / USB Cable from display L.500 / USB Kabel von Notfalldisplay L.500 / Câble USB de panneau L.500 / Cable USB del panel L.500
<b>4</b>	<b>41451104100</b>	Presa con fusibile / Socket with fuse / Steckdose mit Sicherung / Prise avec fusible / Toma con fusible
<b>5</b>	<b>41451904800</b>	Cablaggio / Wiring / Verkabelung / Câblage / Cableado
<b>5</b>	<b>41452000500</b>	Cavo motoriduttore / Reduction motor cable / Kabel Getriebemotor / Câble motoréducteur / Cable motorreductor
<b>5</b>	<b>41451803550</b>	Kit cablaggi messa a terra / Grounding wiring kit / Erdungskabelbaum / Kit mise à terre / Kit cableado a tierra
<b>6</b>	<b>4120631A</b>	Tubicino siliconico - 5m / Silicon tube - 5m / Silikonrohr - 5m / Petit tuyau en silicone - 5m / Tubo silicónico - 5m
<b>7</b>	<b>41801902500</b>	Spirale Rilsan (30 m.) / Rilsan spiral (30 m.) / Spirale Rilsan (30 M.) / Spirale Rilsan (30 m.) / Espiral Rilsan (30 m.)
<b>7</b>	<b>41801902500A</b>	Spirale Rilsan (5 spire) / Rilsan spiral (5 coils) / Spirale Rilsan (5 Windungen) / Spirale Rilsan (5 spires) / Espiral Rilsan (5 espire)
<b>8</b>	<b>41451904300</b>	Scheda madre / Motherboard / Hauptplatine / Carte mère / Tarjeta madre
<b>8</b>	<b>41451904300A</b>	Sensirion / Sensirion / Sensirion / Sensirion / Sensirion
<b>9</b>	<b>41451003700</b>	Pressostato / Pressure switch / Druckschalter / Pressostat / Presostato
<b>10</b>	<b>41601301850</b>	Componente rilevamento portata aria / Air flow measure component / Bauteil für Messung der Luftmenge / Composent pour la mesuration de la quantité d'air / Componente por la medida de l'aire
<b>11</b>	<b>412007004</b>	Clickson 110°C / Clickson 110°C / Clickson 110°C / Clickson 110°C / Clickson 110°C
<b>12</b>	<b>41451602802</b>	Pannello di emergenza Wireless / Wireless emergency display / Wireless Notfall-Blende / Panneau d'urgence wireless / Panel emergencia wireless
<b>13</b>	<b>41451801600</b>	Cavo flat 20 vie L.600 mm / Flat cable 20 pin L.600 mm / Flat-Kabel 20polig L.600 mm / Cable flat 20 voies L.600 mm / Flat cable 20 vias L.600 mm

## CUTE AIR 8 M1

Gruppo accensione / Ignition group / Entzündung Gruppe / Groupe d'allumage / Grupo ignición

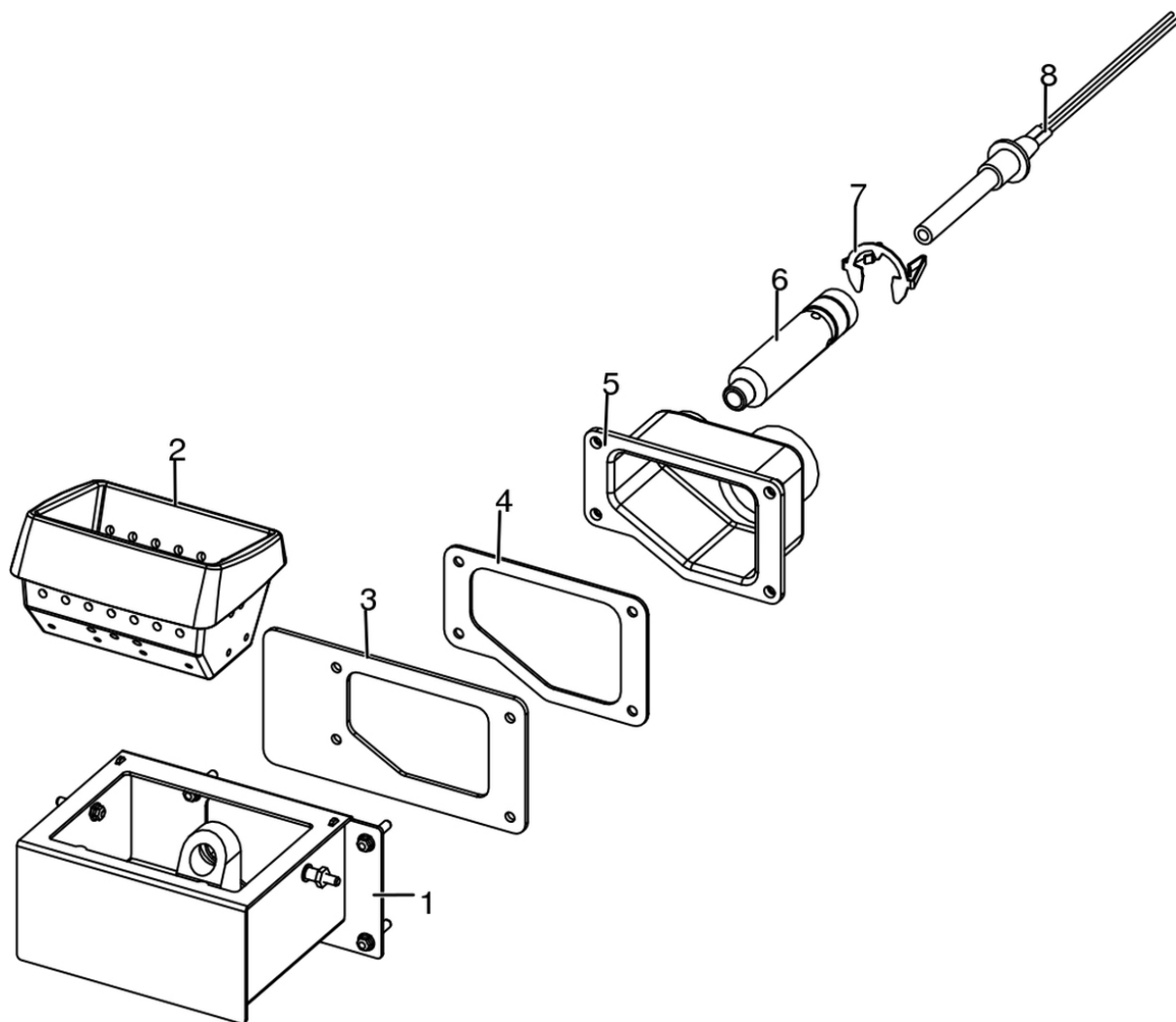

N°	Codice/Code	Descrizioni / Description / Beschreibung / Description / Descripción
1	41411613140V	Tasca braciere / Combustion pot container / Brenntopfkasten / Réciipient brasero / Contenedor brasero
2	41301502400V	Braciere ghisa / Cast iron grate / Brenntopf aus Gusseisen / Brasero en fonte / Brasero en arrabio
3	41801601500	Guarnizione tasca braciere / Combustion pot container gasket / Brenntopfkasten Dichtung / Joint réciipient brasero / Junta contenedor brasero
4	41801602300	Guarnizionaio codolo / Gasket / Dichtung / Joint / Junta
5	41311600100	Codolo / Tool chuck / Einspannschaft / Outil d'emmanchement / Mango
6	41601601000	Condotto candeletta / Sparkplug Conduit / Zündkerzenkanal / Conduit Bougie / Conducto Bujía
7	41201601500	Anello arresto candeletta / Sparkplug stop / Zündkerzestopper / Butée bougie / Tope bujía
8	41451308101	Candeletta 315 Watt / Sparkplug 315 Watt / Zündkerze 315 Watt / Bougie 315 Watt / Bujía 315 Watt
8	41451308150	Kit 25 candelette 315 Watt / 25 Sparkplugs 315 Watt kit / Bausatz 25 Zündkerzen 315 Watt / Kit 25 Bougies 315 Watt / Kit 25 Bujías 315 Watt

## CUTE AIR 8 M1

Gruppo aria comburente / Combustion air group / Verbrennungsluft Gruppe / Groupe air comburant / Grupo aire comburente

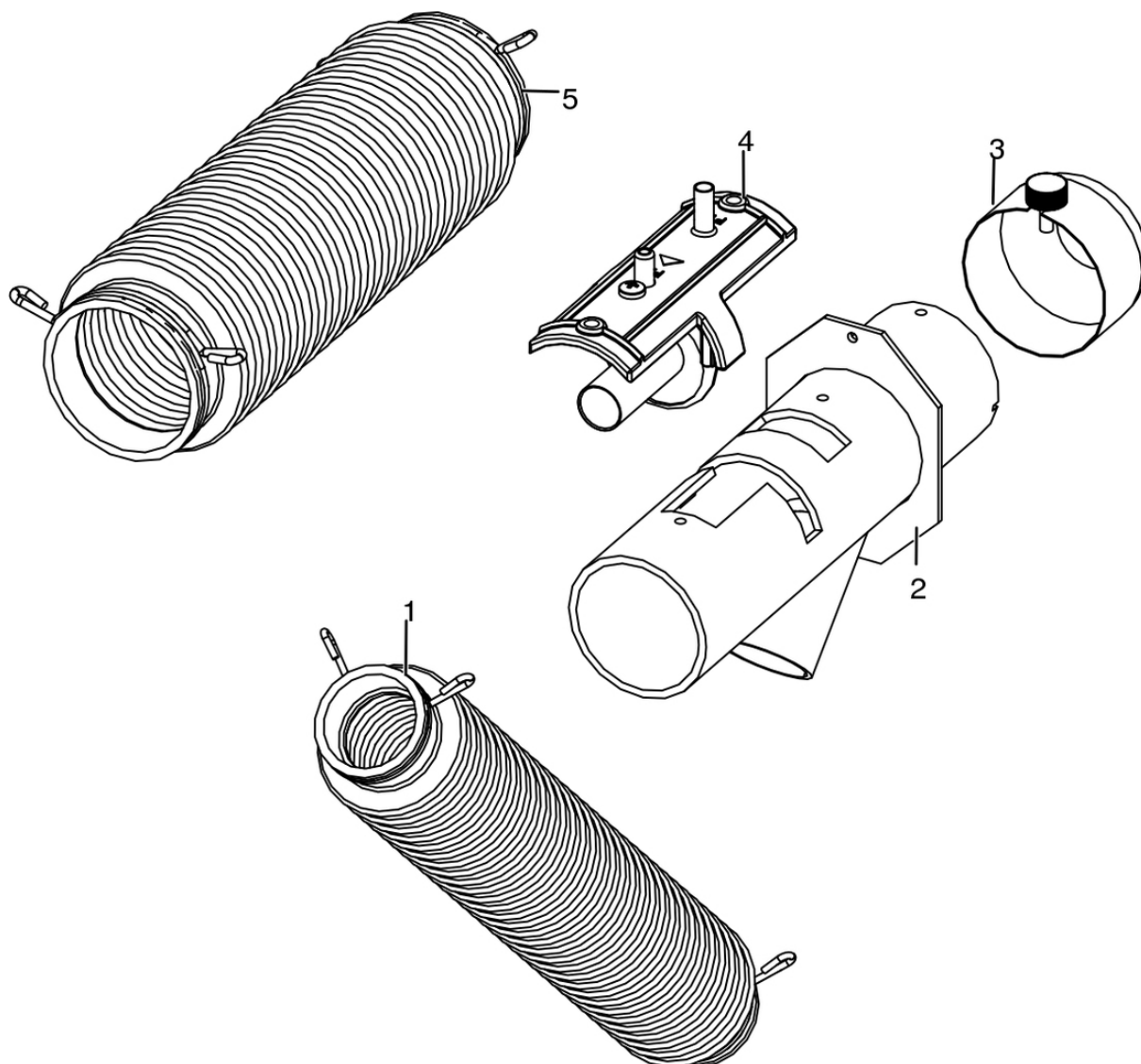

N°	Codice/Code	Descrizioni / Description / Beschreibung / Description / Descripción
1	41801601900	Tubo aspirazione pulizia vetro / Inlet pipe for cleaning glass air / Glassreinigungs Lufteingangrohr / Tuyau entrée pour l'aire de nettoyage du vitre / Tubo entrada por l'aire de limpieza vidrio
2	41601604461	Tubo aspirazione / Air inlet pipe / Lufteingangrohr / Tuyau entrée d'air / Tubo entrada aire
3	41401036100	Filtro antipolvere / Anti-dust filter / Staubschutzfilter / Filtre antipoussière / Filtro de protección polvo
4	41601301850	Componente rilevamento portata aria / Air flow measure component / Bauteil für Messung der Luftmenge / Composent pour la mesuration de la quantité d'air / Componente por la medida de l'aire
5	41801601700	Tubo aspirazione camera combustione / Combustion chamber aspiration tube / Verbrennungskammer Förderrohr / Tuyau aspiration air chambre de combustion / Tubo aspiración aire cámara de combustión

## CUTE AIR 8 M1

Gruppo fumi / Smoke group / Rauchgruppe / Groupe fumées / Grupo de humos

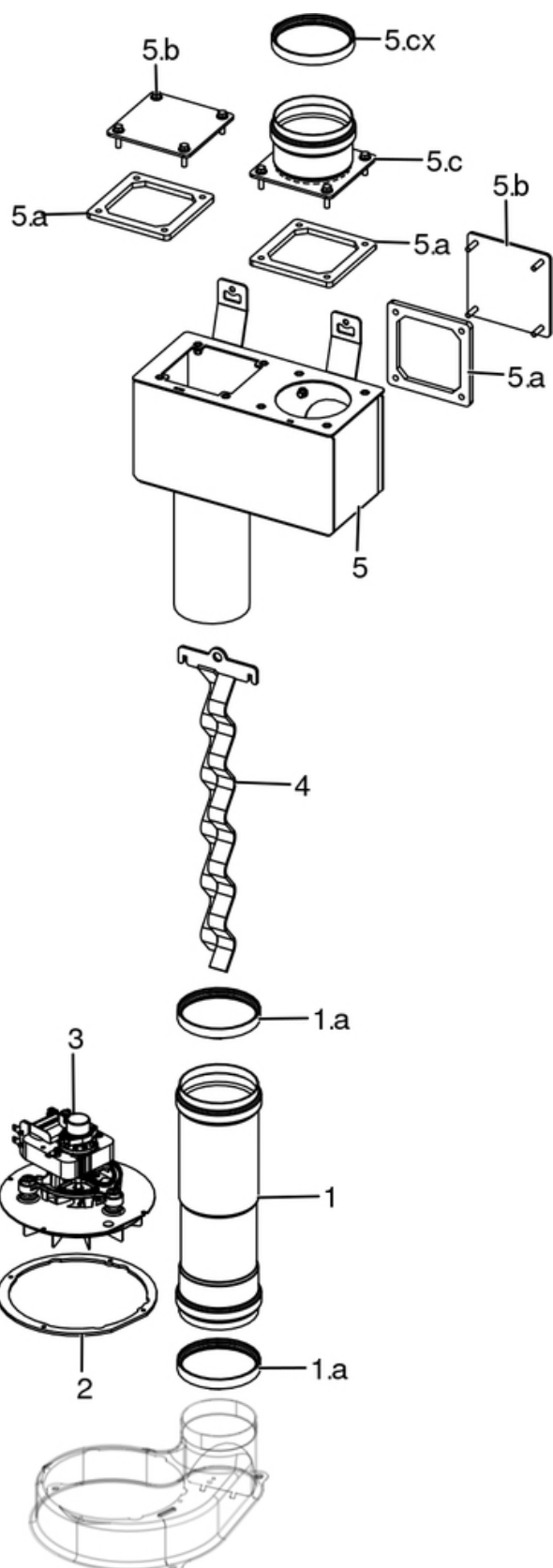

N°	Codice/Code	Descrizioni / Description / Beschreibung / Description / Descripción
<b>1</b>	<b>41601901850</b>	Tubo fumi c/guarnizione / Smoke pipe w/gasket / Rauchgasrohr mit Dichtung / Tuyau de fumées avec joint / Tubo de humos c/junta
<b>1.a</b>	<b>40120969</b>	Guarnizione silicone (5pz) / Silicone Gasket (5pc.) / Silikondichtung (5 St.) / Joint en silicone / Junta en silicona
<b>2</b>	<b>41801600800</b>	Guarnizione ventilatore fumi / Smoke exhaust fan gasket / Dichtung Rauchabsauggebläse / Joint Ventilateur aspiration fumées / Junta ventilador aspiración humos
<b>3</b>	<b>41451503200</b>	Ventilatore fumi stagno / Air-tight smoke exhausted fan / Luftdichtes Rauchgasgebläse / Ventilateur fumées étanche / Ventilador humos hermético
<b>3</b>	<b>41451703000</b>	Encoder per ventilatore fumi marchio EBM / Encoder for EMB smoke fan / Encoder für EBM Rauchgasgebläse / Encoder pour ventilateur des fumées marque EBM / Encoder para ventilador humos marca EBM
<b>3</b>	<b>41451209300</b>	Encoder per ventilatore fumi marchi LN2/SIT / Encoder for LN2/SIT smoke fan / Encoder für LN2/SIT Rauchgasgebläse / Encoder pour ventilateur des fumées marques LN2/SIT / Encoder para ventilador humos marcas LN2/SIT
<b>3</b>	<b>41452009200</b>	Encoder ventilatore / Fan encoder / Lüfter Encoder / Encodeur de ventilateur / Codificador de ventilador
<b>4</b>	<b>41401905540</b>	Turbolatore / Turbulator / Propeller des Schabers / Turbulateur / Rascador
<b>5</b>	<b>437019081</b>	Scatola fumi / Ash box / Rauchabzug / Boîte à fumée / Caja humos
<b>5.a</b>	<b>41801902300</b>	Guarnizione scatola fumi / Smoke box gasket / Dichtung Rauchabzug / Joint boîte à fumée / Junta caja humos
<b>5.b</b>	<b>4141192151000</b>	tappo scatola fumi / Plug fume box / Klappe Rauchabzug / Clapet boîte à fumée / Tapon caja de humos
<b>5.c</b>	<b>41601901350</b>	Flangia con guarnizione / Flange with gasket / Flansch mit Dichtung / Bride avec joint / Brida con junta

## CUTE AIR 8 M1

Gruppo ventilazione / Ventilation group / Lüftungsgruppe / Groupe de ventilation / Grupo de ventilación

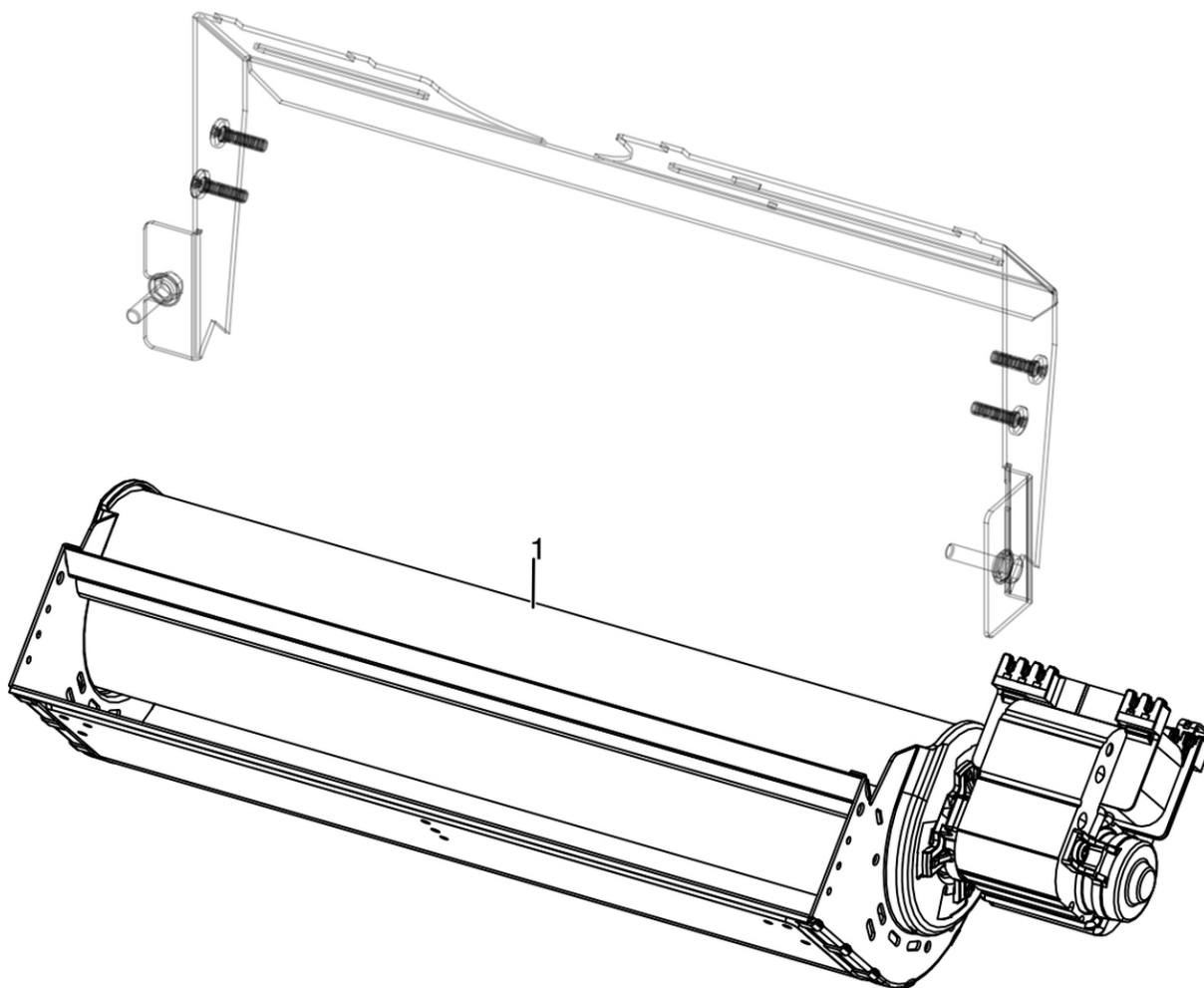

N°	Codice/Code	Descrizioni / Description / Beschreibung / Description / Descripción
1	41451802100	Ventilatore tangenziale / Warm air fan / Luftgebläse / Ventilateur air / Ventilador aire
1	4120572A	Guarnizione a nastro 6 mm (5 mt.) per porta / Door strip gasket 6 mm (5 m) / Türbanddichtung 6 mm (5 m) / Joint ruban 6 mm (5 m) pour porte / Guarnición de cinta para puerta 6 mm (5 m)
1	4120572B	Guarnizione a nastro 6 mm (50 mt.) per porta / Door strip gasket 6 mm (50 m) / Türbanddichtung 6 mm (50 m) / Joint ruban 6 mm (50 m) pour porte / Guarnición de cinta para puerta 6 mm (50 m)