

NIMA

Componenti Struttura Esterna / External structure components / Bauteile Aussenkorpus / Composants structure externe / Componentes estructura externa

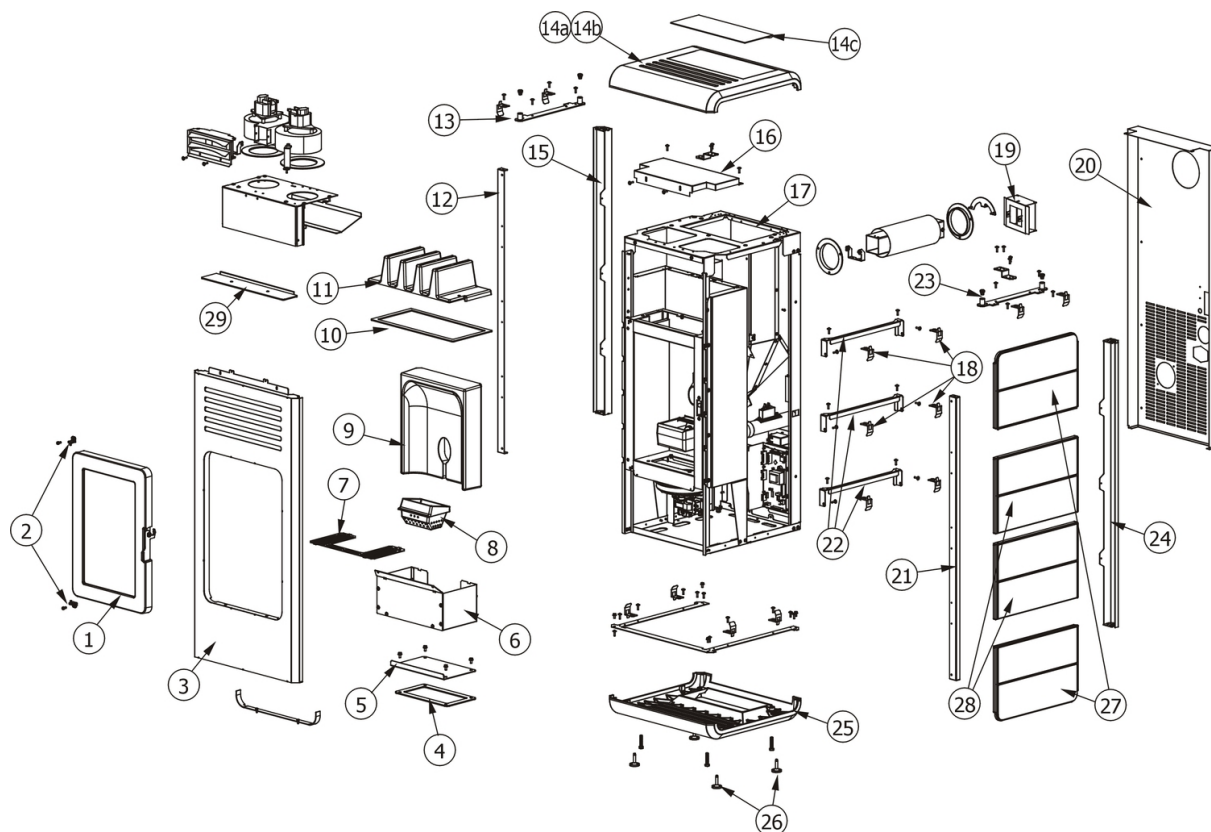

N°	Codice/Code	Descrizioni / Description / Beschreibung / Description / Descripcion
1	41300901550	Porta completa / Complete door / Komplette Tür / Porte complète / Puerta completa
2	412008063	Cerniere porta fuoco (2 pz) / Fire door hinge (2pcs) / Scharnier Feuertür (2 Stck) / Charnière porte foyer (2 pcs) / bisagra puerta del hogar (2 pz)
3	41400962460	Frontale in acciaio nero / Frontal black steel panel / Fassade aus schwarzen Stahl / Paneau frontal en acier noir / Frontal en acero negro
4	418008025	Guarnizione / Gasket / Dichtung / Joint / Junta
4	4180080251	Kit 50 guarnizioni / Kit 50 gaskets / Bausatz 50 Dichtungen / Kit 50 joints / Kit 50 juntas
5	41400906330V	Tappo ispezione vano fumi / Smoke compartment inspection plug / Inspektionsdeckel Rauchabzug / Clapet inspection compartiment fumées / Tapón inspección compartimento humos
6	41400906431V	Cassetto cenere / Ash drawer / Aschenkasten / Tiroir à cendres / Cajón ceniza
7	41400906610V	Griglia focolare / Fire box grille / Feuerstellenrost / Grille foyer / Rejilla hogar
8	413008003	Braciere completo in ghisa / Cast iron complete grate / Kompletter Brennertopf aus Gusseisen / Brasero complet en fonte / Brasero completo de arrabio
9	43650151	Schiena in Alutec® / Alutec® back / Rückwand aus Alutec® / Fond en Alutec® / Parte trasera en Alutec®
10	41800802600	Kit 50 guarnizioni / Kit 50 gaskets / Bausatz 50 Dichtungen / Kit 50 joints / Kit 50 juntas
10	41800802601	Guarnizione / Gasket / Dichtung / Joint / Junta
11	413008001	Scambiatore in ghisa / Cast iron exchanger / Gusseiserne Wärmetauscher / Echangeur en fonte / Intercambiador en arrabio
12	41400963030	Montante anteriore DX-SX / Anterior L-R vertical rod / Vordere Montageleiste LI-RE / Montant antérieur D-G / Montante anterior IZDO-DCHO
13	41400961840V	Staffa bloccaggio DX-SX / L.-R. upright bracket / Oberer Bügel LI-RE / Étrier supérieur D-G / Abrazadera superior IZDA-DCHA
14a	41310900450	Top in acciaio completo / Complete steel top / Komplette Abdeckplatte aus Edelstahl / Dessous complet en acier / Top completo en acero
14b	41310900460	Top in acciaio nero verniciato / Black painted steel top / Abdeckplatte aus Stahl Schwarz lackiert / Dessus en acier laqué noir / Top en acero negro barnizado

14c	41400963660	Coperchio serbatoio pellet / Pellet hopper cover / Deckel Pelletbehälter / Couvercle réservoir pellet / Tapa depósito pellet
15	41400962060	Montante posteriore DX-SX / L.-R. rear vertical rod / Hintere Montageleiste LI-RE / Montant postérieur D-G / Montante posterior IZDO-DCHO
16	41400963330V	Griglia antintrusione / Protection grille / Stoßdämpfersgitter / Grille de protection / Rejilla antiintrusión
17	41400907563	Supporto top / Top support / Deckelhaltebügel / Support du dessus / Soporte del top
18	41400963230	Staffe fissaggio ceramiche (20 pz.) / Ceramic fastening brackets (20 pcs.) / Befestigungsbügel Keramikfliesen (20 Stck.) / Étriers fixation carreaux en céramique (20 p.ces) / Abrazaderas de fijación cerámicas (20 piezas)
19	41400910500V	Diffusore aria calda / Hot air diffuser / Warmluftdiffusor / Diffuseur air chaude / Difusor aire caliente
20	41400963460	Schiena esterna in acciaio / Steel external back / Aussenrückwand aus Stahl / Fond extérieur en acier / Panel trasero externo en acero
21	41400963030	Montante anteriore DX-SX / Anterior L-R vertical rod / Vordere Montageleiste LI-RE / Montant antérieur D-G / Montante anterior IZDO-DCHO
22	41400963130	Staffa bloccaggio ceramiche / Ceramic bracket / Kermikbügel / Étrier pour les ceramiques / Abrazadera cerámicas
23	41400961840V	Staffa bloccaggio DX-SX / L.-R. upright bracket / Oberer Bügel LI-RE / Étrier supérieur D-G / Abrazadera superior IZDA-DCHA
24	41400962060	Montante posteriore DX-SX / L.-R. rear vertical rod / Hintere Montageleiste LI-RE / Montant postérieur D-G / Montante posterior IZDO-DCHO
25	41310900560	Base in acciaio / Steel base / Basis aus Edelstahl / Base en acier / Base en acero
26	4120618	Piedini di appoggio (4 pz) / Support feet (4 pcs) / Einstellfüße (4 Stck) / Vérins d'appui (4 pcs) / Pies de apoyo (4 pz)
27	6909043	Rivestimento completo Bianco / Complete White cladding / Komplette Verkleidung Weiss / Habillage complète Blanc / Revestimiento completo Blanco
27	41250905160	Ceramiche laterali sup. ed inf. white / White upp. and low. side ceramics / Keramikseiten ob. und unt. White / Céramiques latérales sup. et inf. white / Cerámicas laterales sup. e inf. white
27	6909043	Rivestimento completo Bianco / Complete White cladding / Komplette Verkleidung Weiss / Habillage complète Blanc / Revestimiento completo Blanco
27	41250905260	Ceramiche laterali sup. ed inf. bordeaux / Bordeaux upp. and low. side ceramics / Keramikseiten ob. und unt. Bordeaux / Céramiques latérales sup. et inf. bordeaux / Cerámicas laterales sup. e inf. bordeaux
27	41250905360	Ceramiche laterali sup. ed inf. warm grey / Warm grey upp. and low. side ceramics / Keramikseiten ob. und unt. Warm Grey / Céramiques latérales sup. et inf. warm grey / Cerámicas laterales sup. e inf. warm grey
27	41251102800	Ceramiche laterali sup. ed inf. Serpentino / Serpentino upp. and low. side ceramics / Keramikseiten ob. und unt. Serpentino / Céramiques latérales sup. et inf. Serpentino / Cerámicas laterales sup. e inf. Serpentino
27	41251103300	Ceramiche laterali sup. ed inf. Sandstone / Sandstone upp. and low. side ceramics / Keramikseiten ob. und unt. Sandstone / Céramiques latérales sup. et inf. Sandstone / Cerámicas laterales sup. e inf. Sandstone
28	6909043	Rivestimento completo Bianco / Complete White cladding / Komplette Verkleidung Weiss / Habillage complète Blanc / Revestimiento completo Blanco
28	41250906160	Ceramica laterale centrale white / White side centre ceramic / Seitliche mittlere Keramik White / Céramique latérale centrale white / Cerámica lateral central white
28	41250906260	Ceramica laterale centrale bordeaux / Bordeaux side centre ceramic / Seitliche mittlere Keramik Bordeaux / Céramique latérale centrale bordeaux / Cerámica lateral central bordeaux
28	41250906360	Ceramica laterale centrale warm grey / Warm grey side centre ceramic / Seitliche mittlere Keramik Warm Grey / Céramique latérale centrale warm grey / Cerámica lateral central warm grey
28	41251102900	Ceramica laterale centrale Serpentino / Serpentino side centre ceramic / Seitliche mittlere Keramik Serpentino / Céramique latérale centrale Serpentino / Cerámica lateral central Serpentino
28	41251103400	Ceramica laterale centrale Sandstone / Sandstone side centre ceramic / Seitliche mittlere Keramik Sandstone / Céramique latérale centrale Sandstone / Cerámica lateral central Sandstone
29	41400939231	Deflettore focolare in acciaio / Steel fire box deflector / Feuerstelleitblech aus Stahl / Déflecteur foyer en acier / Deflector hogar en acero

NIMA

Porta fuoco / Fire door / Feuertür / Porte foyer / Puerta hogar

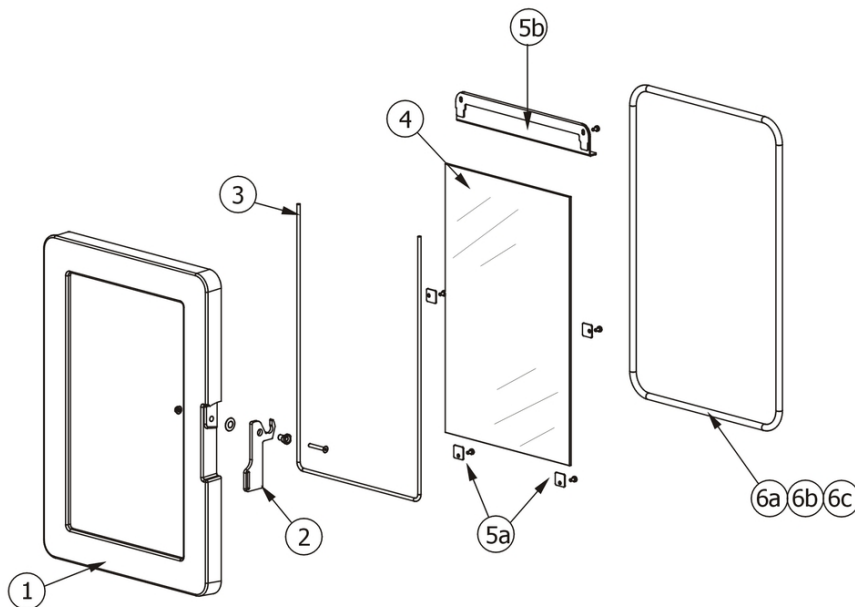

N°	Codice/Code	Descrizioni / Description / Beschreibung / Description / Descripción
1	41300901500V	Telaio porta in ghisa / Cast iron door frame / Türrahmen aus Gusseisen / Cadre porte en fonte / Marco puerta en arrabio
2	41400939760	Maniglia completa / Complete handle / Kompletter Griff / Poignée complète / Tirador completo
3	4120106	Guarnizione a nastro fireglass / Fireglass tape gasket / Banddichtung Fireglass / Joint ruban Fireglass / Guarnición a cinta Fireglass
4	41700901060	Vetroceramico completo di guarnizione / Glass with gasket / Glaskeramikscheibe mit Dichtung / Vitrocéramique avec joint / Cristal cerámico con guarnición
5a	41401077430	Staffe di fissaggio vetroceramico (4 pz.) / Pyroceram fastening brackets (4 pcs.) / Befestigungsbügel Glaskeramik (4 Stck.) / Étrier de fixation vitrocéramique (4 pz.) / Abrazaderas de fijación vidrio cerámico (4 piezas)
5b	41400939630V	Deflettore porta / Door deflector / Leitblech der Tür / Déflecteur de la porte / Deflector de la puerta
6a	4120103A	Cordino fibroceramico Ø 10 mm (5 mt.) / Ceramic fibre cord Ø 10 mm (5 m) / Keramikfaserschnur Ø 10 mm (5 m) / Cordon en fibre céramique Ø 10 mm (5 m) / Junta a cuerda de fibra cerámica Ø 10 mm (5 m)
6b	4120103B	Cordino fibroceramico Ø 10 mm (50 mt.) / Ceramic fibre cord Ø 10 mm (50 m) / Keramikfaserschnur Ø 10 mm (50 m) / Cordon en fibre céramique Ø 10 mm (50 m) / Junta a cuerda de fibra cerámica Ø 10 mm (50 m)
6c	41201031	Kit sostituzione cordino (cordino+silicone) Ø 10 mm / Cord replacement kit (cord + silicon) Ø 10 mm / Schnuraustauschsatz (Schnur+Silikon) Ø 10 mm / Kit remplacement cordon (cordon + silicone) Ø 10 mm / Kit sustitución junta a cuerda (junta a cuerda+silicón) Ø 10 mm

NIMA

Componenti interni elettronici e meccanici / Electronic and mechanical internal components / Interne elektronische und mechanische Bauteile / Composants électroniques et mécaniques internes / Componentes internos electrónicos y mecánicos

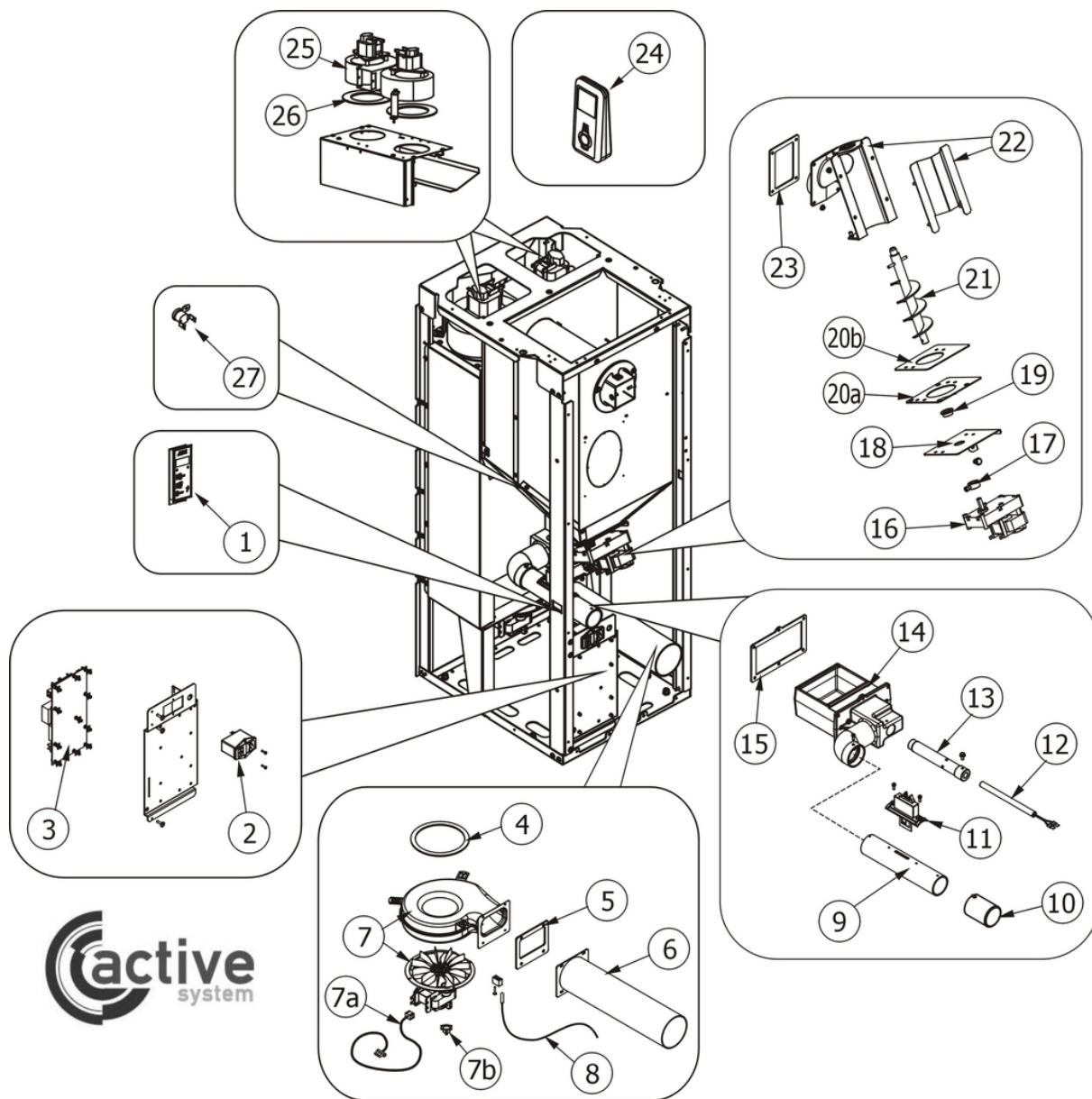

N°	Codice/Code	Descrizioni / Description / Beschreibung / Description / Descripción
1	41450900700	Pannello di emergenza / Emergency panel / Notfalldisplay / Tableau de secours / Panel d'emergencia
1	41450902500	Cavo flat / Flat cable / Flat-Kabel / Cable flat / Cable flat
1	41801499750	Kit 868 / Kit 868 / Kit 868 / Kit 868 / Kit 868
2	4160459	Pulsante accensione / On/Off button / Zündungstaste / Touche d'allumage / Botón encendido
3	41450907601	Scheda madre / Motherboard / Hauptplatine / Carte mère / Tarjeta madre
3	41801499750	Kit 868 / Kit 868 / Kit 868 / Kit 868 / Kit 868
4	41801002600	Guarnizione adesiva voluta fumi / Adhesive gasket smoke volute / Haftendichtung Rauchvolute / Joint adhesive volute fumées / Junta adhesiva voluta humos
4	41801599850	Kit 50 guarnizioni / Kit 50 gaskets / Bausatz 50 Dichtungen / Kit 50 joints / Kit 50 juntas
5	418008030	Guarnizione / Gasket / Dichtung / Joint / Junta
6	416008010	Tubo uscita fumi / Smoke outlet pipe / Rohr Rauchabzug / Tuyau sortie fumées / Tubo salida humos

7	41451003202	Ventilatore aspirazione fumi / Smoke exhausted fan / Rauchabsauggebläse / Ventilateur aspiration fumées / Ventilador aspiración humos
7	41801102500	Guarnizione / Gasket / Dichtung / Joint / Junta
7a	4160477	Cavo ENCODER / ENCODER cable / Drehzahlmesser-kabel / Câble ENCODER / Cable ENCODER
7b	41451209300	Encoder per ventilatore fumi marchi LN2/SIT / Encoder for LN2/SIT smoke fan / Encoder für LN2/SIT Rauchgasgebläse / Encoder pour ventilateur des fumées marques LN2/SIT / Encoder para ventilador humos marcas LN2/SIT
8	41450901800	Sonda fumi Active System / Smoke sensor Active System / Rauchgasfühler ACTIVE SYSTEM / Sonde fumées ACTIVE SYSTEM / Sonda humos Active System
9	41200901200	Tubo ingresso aria / Air inlet pipe / Lufteringangsrohr / Tuyau entrée air / Tubo entrada aire
10	41401036100	Filtro antipolvere / Anti-dust filter / Staubschutzfilter / Filtre antipoussière / Filtro de protección polvo
11	41451205000	Sensore aria completo / Complete air sensor / Kompletter Luftfühler / Capteur air complet / Sensor aire completo
12	41450905000	Candeletta accensione pellet / Pellet ignition sparkplug / Zündkerze Pelletzündung / Bougie d'allumage pellet / Bujía encendido pellet
12	41801599550	Kit 50 candelette / 50 Sparkplugs kit / Bausatz 50 Zündkerzen / Kit 50 Bougies / Kit 50 Bujías
13	41200903900	Condotto candeletta / Sparkplug conduit / Zündkerzenkanal / Conduit bougie / Conducto bujía
14	414008043	Tasca braciere in ghisa / Combustion pot container / Brenntopfkasten aus Gusseisen / Récipient braséro / Contenedor brasero
14	41401069141V	Tasca braciere / Combustion pot container / Brenntopfkasten / Récipient braséro / Contenedor brasero
15	418008027	Guarnizione / Gasket / Dichtung / Joint / Junta
16	4160278	Motoriduttore 1,5 RPM / Reduction motor 1,5 RPM / Getriebemotor 1,5 RPM / Motorréducteur 1,5 TPM / Motorreductor 1,5 RPM
17	4120398	Connettore motoriduttore-coclea / Reduction motor-feed screw connector / Verbindung Getriebemotor-Schnecke / Connecteur motorréducteur-vis sans fin / Conector motorreductor-cóclea
18	41400944351	Base della coclea / Feed screw base / Untergestell der Förderschnecke / Base de la vis sans fin / Base de la cóclea
19	4120614	Boccola grafitata (2 pz) / Etched bush (2 pcs) / Graphitbuchse (2 Stck) / Bride graphitée (2 pcs) / Brida grafitada (2 pz)
20a	4120615	Guarnizione base della coclea / Feed screw base gasket / Dichtung Untergestell der Förderschnecke / Joint pour la base de la vis sans fin / Junta base de la cóclea
20b	41400903310	Flangia condotto coclea / Base of feed screw conduit / Untergestell Rohrleitung der Förderschnecke / Base du conduit de la vis sans fin / Base de conducto de la cóclea
21	41200901040	Coclea di caricamento pellet / Pellet feed screw / Pelletsförderschnecke / Vis sans fin pour chargement du pellet / Cóclea de carga pellet
22	41401077540V	Condotto della coclea / Conduit of feed screw / Rohrleitung der Förderschnecke / Conduit de la vis sans fin / Conducto de la cóclea
24	41450901500	Telecomando / Remote control / Fernbedienung / Télécommande / Mando a distancia
24	41451106000	Telecomando / Remote control / Fernbedienung / Télécommande / Mando a distancia
24	41801499750	Kit 868 / Kit 868 / Kit 868 / Kit 868 / Kit 868
23	418008029	Guarnizione / Gasket / Dichtung / Joint / Junta
25	41451002903	Motore ventilatore portata 170 m3/h / Fan motor capacity 170 m3/h / Gebläsemotor Leistung 170 m3/h / Moteur ventilateur débit 170 m3/h / Motor ventilador caudal 170 m3/h
27	412007004	Clickson 110°C / Clickson 110°C / Clickson 110°C / Clickson 110°C / Clickson 110°C
26	418008018	Guarnizione ventilatore / Fan gasket / Dichtung des Gebläses / Joint du ventilateur / Junta ventilador