

PANORAMA

Componenti Struttura Esterna / External structure components / Bauteile Aussenkorpus / Composants structure externe / Componentes estructura externa

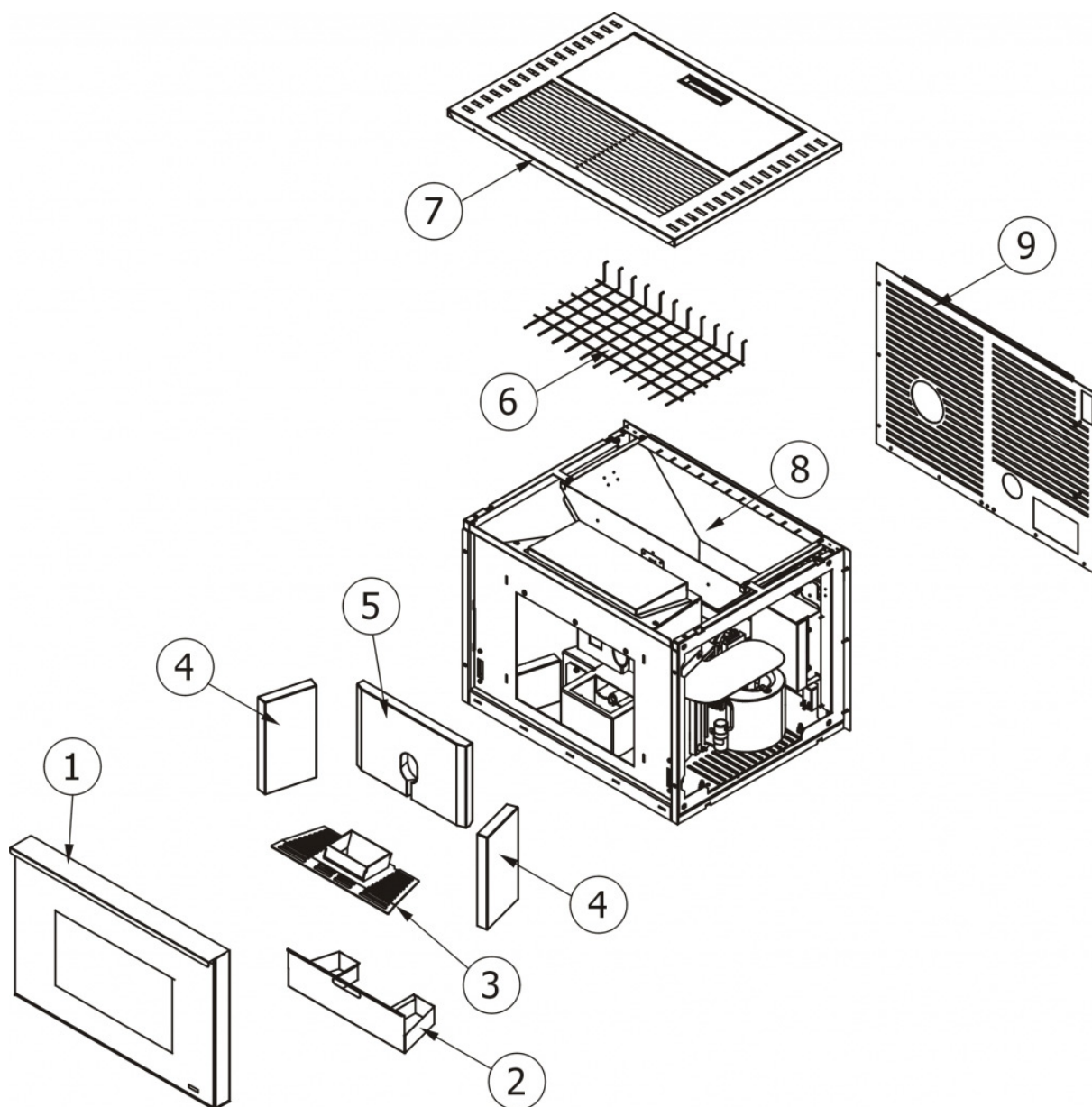

N°	Codice/Code	Descrizioni / Description / Beschreibung / Description / Descripción
1	4362030	Porta completa finitura nero verniciato / Complete painted black door / Komplette Tür Ausführung Schwarz lackiert / Porte complète finition laquée noire / Puerta completa acabado negro barnizado
2	41400926130	Cassetto cenere / Ash drawer / Aschenkasten / Tiroir à cendres / Cajón ceniza
3	42041003	Braciere / Combustion pot / Brennerpotf / Pot de combustion / Brasero
4	43650142	Fianco DX-SX in Alutec® / Alutec® L.-R. side / RE.-LI. Aussenseite aus Alutec® / Côté D.-G. en Alutec® / Lateral DCHO-IZDO en Alutec®
5	43650141	Schiena in Alutec / Alutec® back / Rückwand aus Alutec® / Fond en Alutec® / Parte trasera en Alutec®
6	4120975	Griglia protezione / Protection grille / Schutzgitter / Grille de protection / Rejilla de protección
7	43640997	Coperchio serbatoio pellet / Pellet hopper cover / Deckel Pelletbehälter / Couvercle réservoir pellet / Tapadera depósito pellet
8	43640983	Serbatoio pellet / Pellet hopper / Pelletbehälter / Réservoir pellet / Depósito pellet
9	43640996	Schiena forata posteriore nera / Black perforated back / Gelochte hintere schwarze Rückwand / Dossieret postérieur perforé noir / Parte trasera perforada posterior negra

PANORAMA

Porta fuoco / Fire door / Feuertür / Porte foyer / Puerta hogar

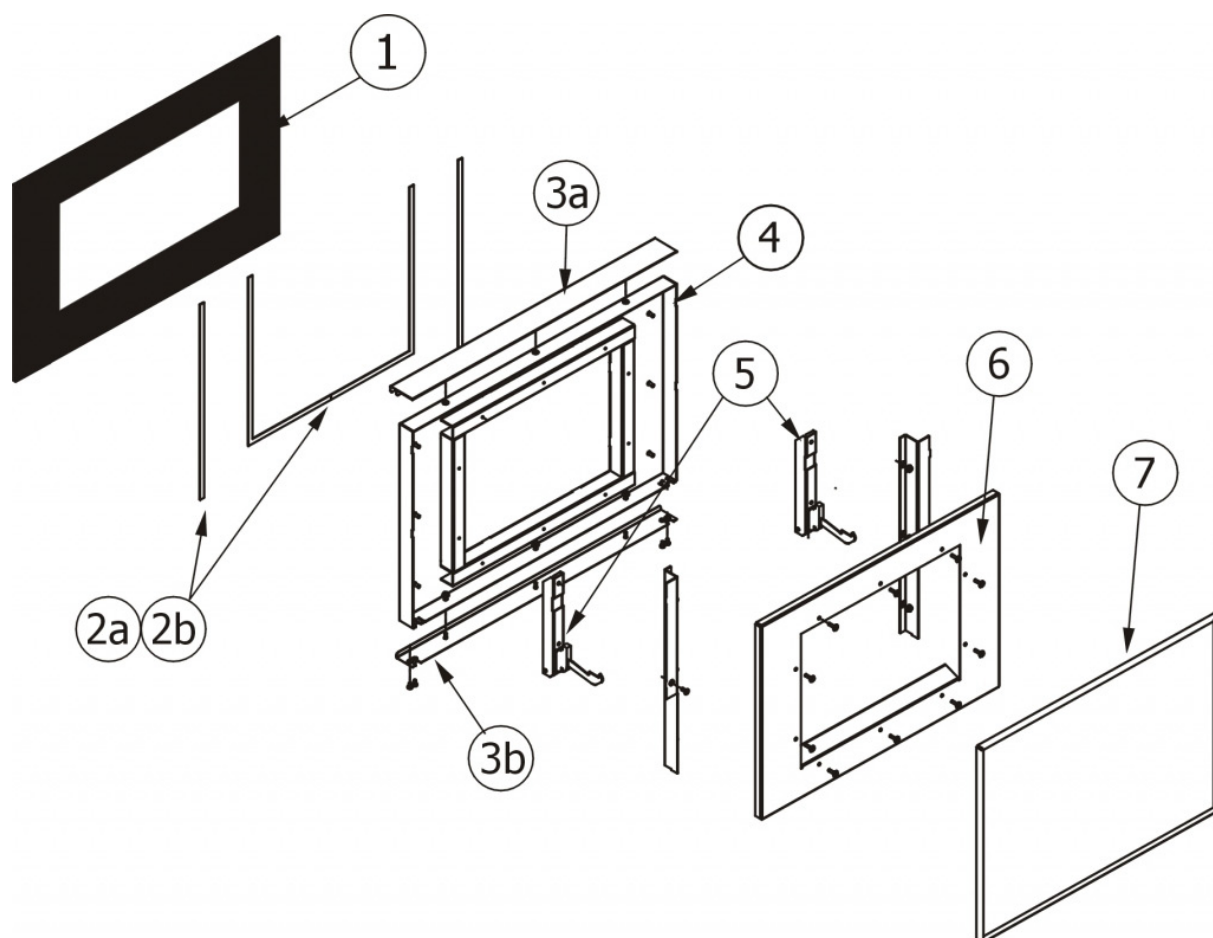

N°	Codice/Code	Descrizioni / Description / Beschreibung / Description / Descripción
1	4170197	Vetroceramico con guarnizione 8 mm / Glass with gasket 8 mm / Glaskeramikscheibe mit Dichtung 8 mm / Vitrocéramique avec joint 8 mm / Cristal cerámico con guarnición de 8 mm
2a	4120573A	Guarnizione a nastro 8 mm (5 mt.) per porta / Door strip gasket 8 mm (5 m) / Türbanddichtung 8 mm (5 m) / Joint ruban 8 mm (5 m) pour porte / Guarnición de cinta para puerta 8 mm (5 m)
2b	4120573B	Guarnizione a nastro 8 mm (50 mt.) per porta / Door strip gasket 8 mm (50 m) / Türbanddichtung 8 mm (50 m) / Joint ruban 8 mm (50 m) pour porte / Guarnición de cinta para puerta 8 mm (50 m)
3a	42021542	Profilo superiore di fissaggio vetro con maniglia / Upper profile for glass fastening with handle / Oberes Profil der Glasbefestigung mit Griff / Profil supérieur de fixation de la vitre avec poignée / Perfil superior de fijación de cristal con tirador
3b	42021544	Profilo inferiore di fissaggio vetro / Lower profile for glass fastening / Unteres Profil der Glasbefestigung / Profil inférieur de fixation de la vitre / Perfil inferior de fijación de cristal
5	412008012	Cerniera a molla ancoraggio porta / Door anchoring spring loaded hinge / Federscharnier Türbefestigung / Charnière à ressort fixation porte / Bisagra con muelle fijación puerta
6	43620305	Tamponazione interna porta fuoco / Fire door inner filling / Interne Abdichtung Feuerraumtür / Tampon interne de la porte foyer / Taponado interno de la puerta del hogar
7	4120971	Guarnizione / Gasket / Dichtung / Joint / Junta

PANORAMA

Componenti interni / Internal components / Interne Bauteile / Composants internes / Componentes internos

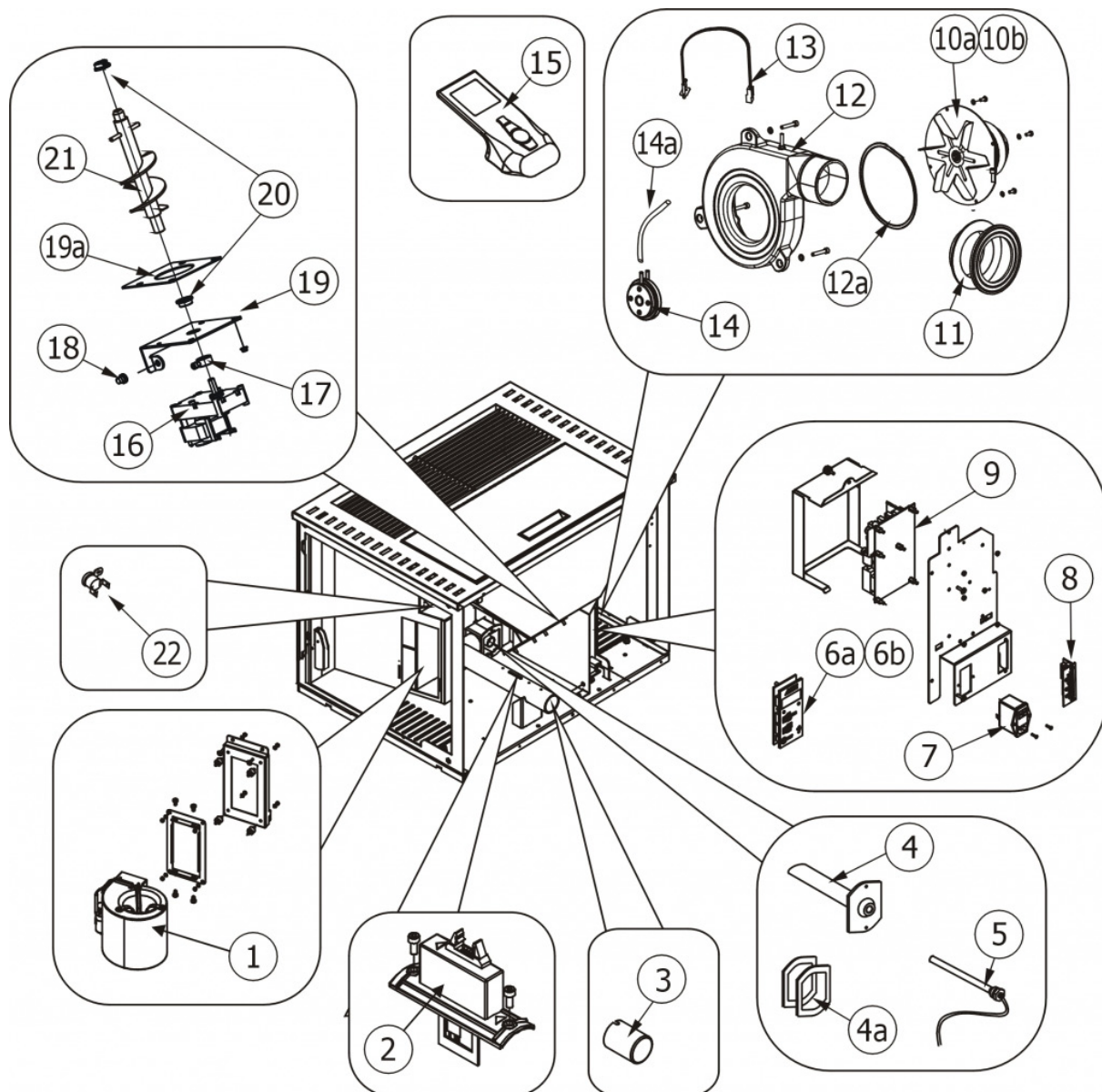

N°	Codice/Code	Descrizioni / Description / Beschreibung / Description / Descripcion
1	4160404	Ventilatore aria / Air fan / Luftgebläse / Ventilateur air / Ventilador aire
2	41451205000	Sensore aria completo / Complete air sensor / Kompletter Luftfühler / Capteur air complet / Sensor aire completo
3	41401036100	Filtro antipolvere / Anti-dust filter / Staubschutzfilter / Filtre antipoussière / Filtro de protección polvo
4	42041071	Condotto candeletta / Sparkplug duct / Zündkerzenkanal / Conduit bougie / Conducto bujía
4a	43640329A	Distanziali condotto candeletta / Sparkplug conduit spacers / Distanzstücke Zündkerzenkanal / Entretoises conduit bougie / Espaciadores conducto bujía
5	41450905000	Candeletta accensione pellet / Pellet ignition sparkplug / Zündkerze Pelletzündung / Bougie d'allumage pellet / Bujía encendido pellet
5	41801599550	Kit 50 candelette / 50 Sparkplugs kit / Bausatz 50 Zündkerzen / Kit 50 Bougies / Kit 50 Bujías
6a	4160403	Pannello emergenza-diagnostica / Diagnostic-emergency panel / Bedienblende Notfälle-Diagnoseprogramm / Tableau secours/diagnostique / Panel socorro/diagnóstico
6b	414509003	Pannello emergenza-diagnostica + Ricevitore RF segnale radio / Diagnostic-emergency panel + RF radio signal receiver / Bedienblende Notfälle-Diagnoseprogramm + RF-Empfänger Funksignal / Tableau secours/diagnostique + Récepteur RF signal radio / Panel de emergencia/diagnóstico + Receptor RF señal radio

7	4160459	Pulsante accensione / On/Off button / Zündungstaste / Touche d'allumage / Botón encendido
8	4160402	Connessioni seriali / Serial connections / Serielle Anschlüsse / Connexions sérielles / Conexiones seriales
9	41450902300	Scheda madre universale Active System Ver. 9.06 / Active System universal motherboard version 9.06 / Hauptplatine Active System 9.06 / Carte mère universal Active versione 9.06 / Tarjeta madre Active System 9.06
10a	4160234	Ventilatore aspirazione fumi / Smoke exhaust fan / Rauchabsauggebläse / Ventilateur aspiration fumées / Ventilador aspiración de humos
10b	4160429	Ventilatore aspirazione fumi / Smoke exhaust fan / Rauchabsauggebläse / Ventilateur aspiration fumées / Ventilador aspiración de humos
11	41801502800	Guarnizione tra voluta e raccordo fumi / Gasket between volute and smoke connection / Dichtung zwischen Volute und Rauchabzug / Joint entre la volute et le raccord des fumées / Junta entre voluta y conexión de humos
12	4130866	Voluta in ghisa / Cast iron volute / Gusseiserne Volute / Volute en fonte / Voluta de arrabio
12a	412007002	Guarnizione / Gasket / Dichtung / Joint / Junta
13	4160469	Sonda fumi / Smoke sensor / Rauchgasfühler / Sonde fumées / Sonda humos
14	4160411	Pressostato 0,25 mbar / Pressure switch 0,25 mbar / Druckwächter 0,25 mbar / Pressostat 0,25 mbar / Presostato 0,25 mbar
14	4160482	Pressostato 0,4 mbar / Pressure gauge 0,4 mbar / Druckschalter 0,4 mbar / Pressostat 0,4 mbar / Presostato 0,4 mbar
14a	4120631A	Tubicino silicónico - 5m / Silicon tube - 5m / Silikonrohr - 5m / Petit tuyau en silicone - 5m / Tubo silicónico - 5m
15	414508025	Telecomando / Remote control / Fernbedienung / Télécommande / Mando a distancia
15	4145111800	Telecomando / Remote control / Fernbedienung / Télécommande / Mando a distancia
16	4160278	Motoriduttore 1,5 RPM / Reduction motor 1,5 RPM / Getriebemotor 1,5 RPM / Motorréducteur 1,5 TPM / Motorreductor 1,5 RPM
17	4120398	Connettore motoriduttore-coclea / Reduction motor-feed screw connector / Verbindung Getriebemotor-Schnecke / Connecteur motorréducteur-vis sans fin / Conector motorreductor-cóclea
18	4120180	Gommini paracolpi (4 pz) / Rubber bumpers (4 pcs.) / Schlagschutzgummi (4 Stck) / Pièces caoutchouc antichoc (4 pcs) / Cauchitos anti-golpes (4 pz)
19	43640168	Base della coclea / Feed screw base / Untergestell der Förderschnecke / Base de la vis sans fin / Base de la cóclea
19a	4120615	Guarnizione base della coclea / Feed screw base gasket / Dichtung Untergestell der Förderschnecke / Joint pour la base de la vis sans fin / Junta base de la cóclea
20	4120614	Boccola grafitata (2 pz) / Etched bush (2 pcs) / Graphitbuchse (2 Stck) / Bride graphitée (2 pcs) / Brida grafitada (2 pz)
21	43640424	Coclea di caricamento pellet / Pellet feed screw / Pellet Förderschnecke / Vis sans fin pour chargement du pellet / Cóclea de carga pellet
22	412007004	Clickson 110°C / Clickson 110°C / Clickson 110°C / Clickson 110°C / Clickson 110°C

PANORAMA

Rivestimenti / Claddings / Verkleidungen / Habillages / Revestimientos

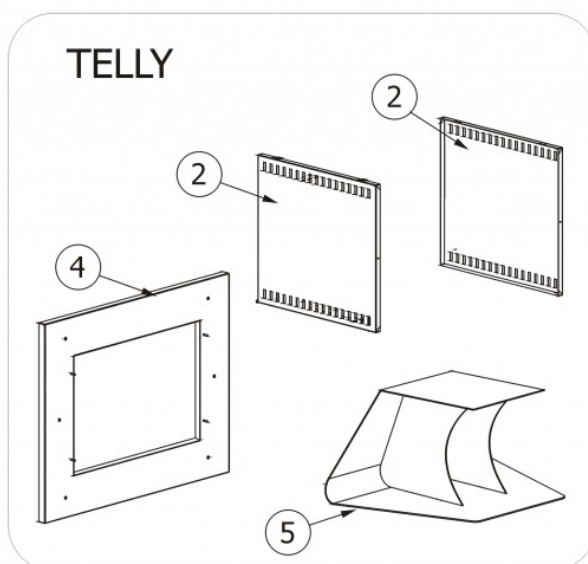
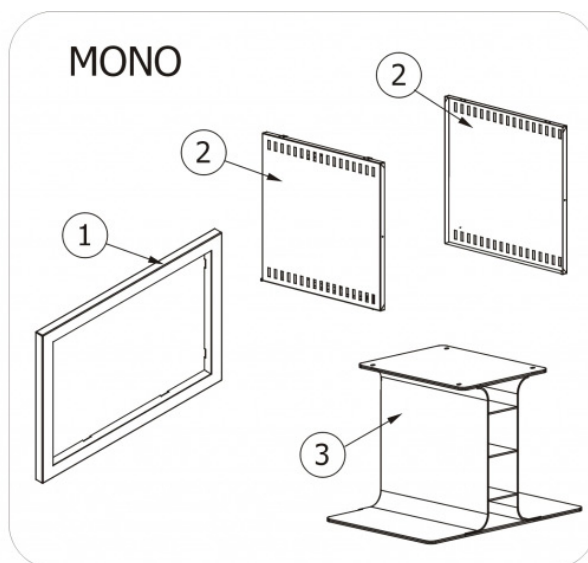
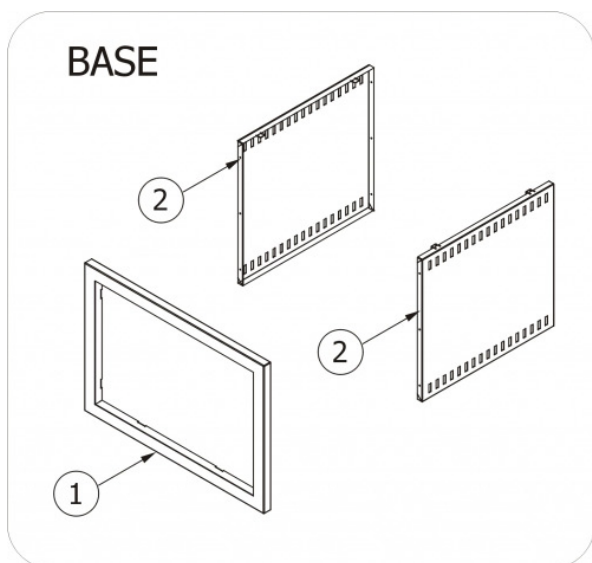

N°	Codice/Code	Descrizioni / Description / Beschreibung / Description / Descripción
1	4305040	Cornice esterna nera / Black outer frame / Schwarzer Außenrahmen / Cadre externe noir / Armazón externo negro
2	4305038	Fianco esterno DX-SX in acciaio nero / Black steel R.-L. external side / RE.-LI. schwarze Stahlaussenseite / Côté D.-G. extérieur en acier laqué noir / Lateral externo DCHO-IZDO en acero negro
3	4305042	Piedistallo rivestimento mod. Mono / Pedestal cladding mod. MONO / Unterteil für Verkleidung Mod. MONO / Socle habillage mod. MONO / Pedestal del revestimiento mod. MONO
4	4305051	Cornice rivestimento mod. Telly / Frame cladding mod. TELLY / Verkleidungseinfassung Mod. TELLY / Cadre habillage mod. TELLY / Armazón del revestimiento mod. TELLY
5	4305049	Cornice acciaio rivestimento Telly / Steel frame cladding TELLY / Stahleinfassung Verkleidung TELLY / Cadre en acier habillage TELLY / Armazón en acero del revestimiento TELLY