

## PHILO

Componenti Struttura Esterna / External structure components / Bauteile Aussenkorpus / Composants structure externe / Componentes estructura externa

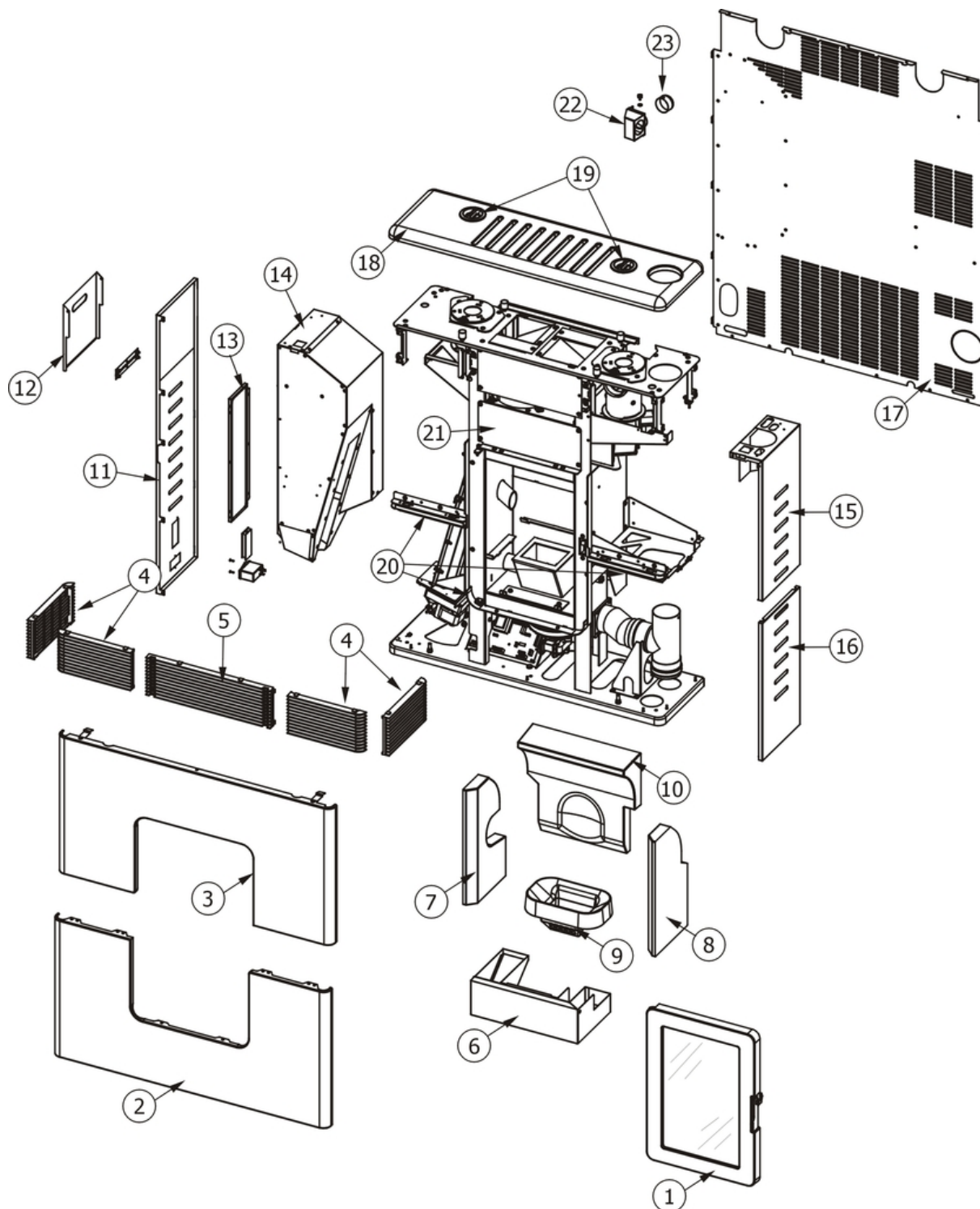

N°	Codice/Code	Descrizioni / Description / Beschreibung / Description / Description
1	41300901550	Porta completa / Complete door / Komplette Tür / Porte complète / Puerta completa
2	6911029	Rivestimento completo White metal / Complete White metal cladding / Komplette Verkleidung White metal / Habillage complète White metal / Revestimiento completo White metal
2	6911030	Rivestimento completo Black metal / Complete Black metal cladding / Komplette Verkleidung Black metal / Habillage complète Black metal / Revestimiento completo Black metal

2	6911031	Rivestimento completo Aluminium metal / Complete Aluminium metal cladding / Komplette Verkleidung Aluminium metal / Habillage complète Aluminium metal / Revestimiento completo Aluminium metal
2	6911032	Rivestimento completo Bordeaux metal / Complete Bordeaux metal cladding / Komplette Verkleidung Bordeaux metal / Habillage complète Bordeaux metal / Revestimiento completo Bordeaux metal
2	6911033	Rivestimento completo Bronze metal / Complete Bronze metal cladding / Komplette Verkleidung Bronze metal / Habillage complète Bronze metal / Revestimiento completo Bronze metal
3	6911029	Rivestimento completo White metal / Complete White metal cladding / Komplette Verkleidung White metal / Habillage complète White metal / Revestimiento completo White metal
3	6911030	Rivestimento completo Black metal / Complete Black metal cladding / Komplette Verkleidung Black metal / Habillage complète Black metal / Revestimiento completo Black metal
3	6911031	Rivestimento completo Aluminium metal / Complete Aluminium metal cladding / Komplette Verkleidung Aluminium metal / Habillage complète Aluminium metal / Revestimiento completo Aluminium metal
3	6911032	Rivestimento completo Bordeaux metal / Complete Bordeaux metal cladding / Komplette Verkleidung Bordeaux metal / Habillage complète Bordeaux metal / Revestimiento completo Bordeaux metal
3	6911033	Rivestimento completo Bronze metal / Complete Bronze metal cladding / Komplette Verkleidung Bronze metal / Habillage complète Bronze metal / Revestimiento completo Bronze metal
4	41801100900	Griglia uscita aria calda / Hot air outlet grille / Gitter Warmluftaustritt / Grille sortie air chaud / Rejilla salida aire caliente
4	41801100900	Griglia uscita aria calda / Hot air outlet grille / Gitter Warmluftaustritt / Grille sortie air chaud / Rejilla salida aire caliente
5	41801100800	Griglia uscita aria calda / Hot air outlet grille / Gitter Warmluftaustritt / Grille sortie air chaud / Rejilla salida aire caliente
6	41401148440	Cassetto cenere / Ash drawer / Aschenkasten / Tiroir à cendres / Cajón ceniza
7	41151001300	Fianco in Alutec / Alutec side / Alutec Seite / Côté en Alutec / Lateral en Alutec
8	41151001400	Fianco in Alutec / Alutec side / Aussenseite aus Alutec / Côté en Alutec / Lateral en Alutec
9	41301100201	Braciere in ghisa / Cast iron grate / Brennertopf aus Gusseisen / Brasero en fonte / Brasero en arrabio
10	41151001200	Schiena in Alutec® / Alutec® back / Rückwand aus Alutec® / Fond en Alutec® / Parte trasera en Alutec®
10	41401135740	Parete asportabile / Amovable Wall / Abnehmbares Wand / Mur démontable / Pared extirpable
10	41411231530	Eccentrico per focolare / Eccentric for fireplace / Exzentrisch für Feuerstelle / Excentrique pour foyer / Excéntrico para hogar
10	41401369330	Schiena in lamiera / Back / Rückwand / Dosseret / Parte trasera
10	41401136830	Supporto schiena in alutec / Alutec support / Alutec unterstützung / Support alutec / Apoyo alutec
11	41401150560	Fianco acciaio / Steel side / Stahlaussenseite / Côté en acier / Lateral en acero
12	41401150730	Coperchio serbatoio / Hopper cover / Deckel Pelletbehälter / Couvercle réservoir / Tapa depósito
13	41401149450	Plexiglass + telaio / Plexiglass + frame / Plexiglass + Rahmen / Plexiglass + cadre / Plexiglass + marco
14	41401148840	Serbatoio pellet / Pellet hopper / Pelletbehälter / Réservoir pellet / Déposito pellet
15	41401149860	Fianco acciaio / Steel side / Stahlaussenseite / Côté en acier / Lateral en acero
16	41401149960	Fianco acciaio / Steel side / Stahlaussenseite / Côté en acier / Lateral en acero
17	41401149660	Schiena esterna in acciaio / External back in steel / Aussenrückwand aus Stahl / Fond extérieur en acier / Panel trasero externo de acero
18	41311100550	Top completo nero / Black complete TOP / Komplette Abdeckplatte schwarz / Dessus complet noir / Top completo negro
19	41801101000	Manopola / Knob / Regler / Pommeau / Botón
19	41801101000	Manopola / Knob / Regler / Pommeau / Botón
20	41401150050	Kit staffe fissaggio rivestimento e riparo sotto-porta / Bracket + bottom door protection kit / Bügel + Schutz Bausatz / Kit étriers + protection sous porte / Kit zunchos + resguardo bajo puerta
21	41401147432V	Scudo frontale / Front cover / Frontalabdeckung / Coverture frontal / Tapa frontal
21	41411236430V	Tamponazione anteriore nera / Black frontal filling / Vordere Stopfung Schwarz / Tampon antérieur noir / Tapa delantera negra
22	41401184750	Convogliatore aria comburente / Combustion air duct / Verbrennungsluft Förder / Convoyeur air de combustion / Conductor aire de combustión
23	41401036100	Filtro antipolvere / Anti-dust filter / Staubschutzfilter / Filtre antipoussière / Filtro de protección polvo

## PHILO

Porta fuoco / Fire door / Feuertür / Porte foyer / Puerta hogar

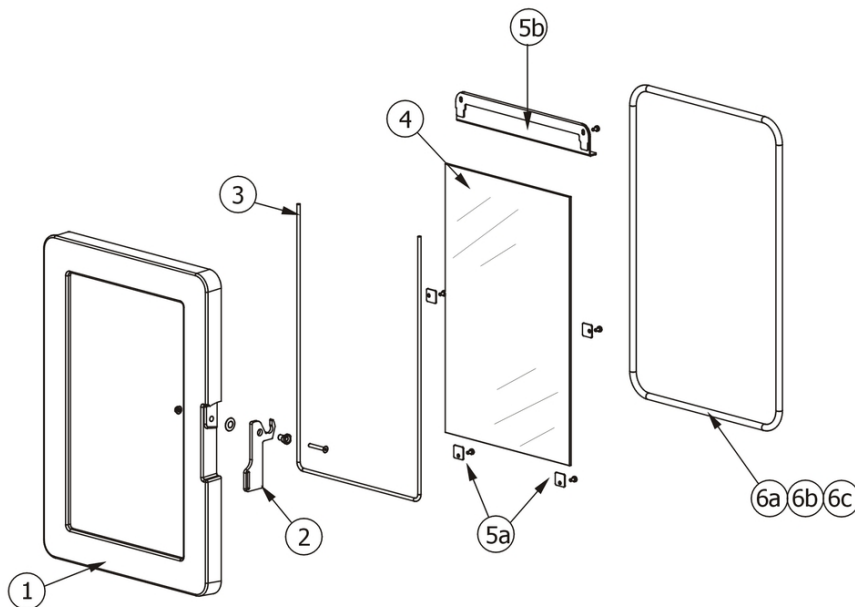

N°	Codice/Code	Descrizioni / Description / Beschreibung / Description / Descripción
1	41300901500V	Telaio porta in ghisa / Cast iron door frame / Türrahmen aus Gusseisen / Cadre porte en fonte / Marco puerta en arrabio
2	41400939760	Maniglia completa / Complete handle / Kompletter Griff / Poignée complète / Tirador completo
3	4120106	Guarnizione a nastro fireglass / Fireglass tape gasket / Banddichtung Fireglass / Joint ruban Fireglass / Guarnición a cinta Fireglass
4	41700901060	Vetroceramico completo di guarnizione / Glass with gasket / Glaskeramikscheibe mit Dichtung / Vitrocéramique avec joint / Cristal cerámico con guarnición
5a	41401077430	Staffe di fissaggio vetroceramico (4 pz.) / Pyroceram fastening brackets (4 pcs.) / Befestigungsbügel Glaskeramik (4 Stck.) / Étrier de fixation vitrocéramique (4 pz.) / Abrazaderas de fijación vidrio cerámico (4 piezas)
5b	41400939630V	Deflettore porta / Door deflector / Leitblech der Tür / Déflecteur de la porte / Deflector de la puerta
6a	4120103A	Cordino fibrocaramico Ø 10 mm (5 mt.) / Ceramic fibre cord Ø 10 mm (5 m) / Keramikfaserschnur Ø 10 mm (5 m) / Cordon en fibre céramique Ø 10 mm (5 m) / Junta a cuerda de fibra cerámica Ø 10 mm (5 m)
6b	4120103B	Cordino fibrocaramico Ø 10 mm (50 mt.) / Ceramic fibre cord Ø 10 mm (50 m) / Keramikfaserschnur Ø 10 mm (50 m) / Cordon en fibre céramique Ø 10 mm (50 m) / Junta a cuerda de fibra cerámica Ø 10 mm (50 m)
6c	41201031	Kit sostituzione cordino (cordino+silicone) Ø 10 mm / Cord replacement kit (cord + silicon) Ø 10 mm / Schnuraustauschsatz (Schnur+Silikon) Ø 10 mm / Kit remplacement cordon (cordon + silicone) Ø 10 mm / Kit sustitución junta a cuerda (junta a cuerda+silicón) Ø 10 mm

## PHILO

Componenti interni elettronici e meccanici / Electronic and mechanical internal components / Interne elektronische und mechanische Bauteile / Composants électroniques et mécaniques internes / Componentes internos electrónicos y mecánicos

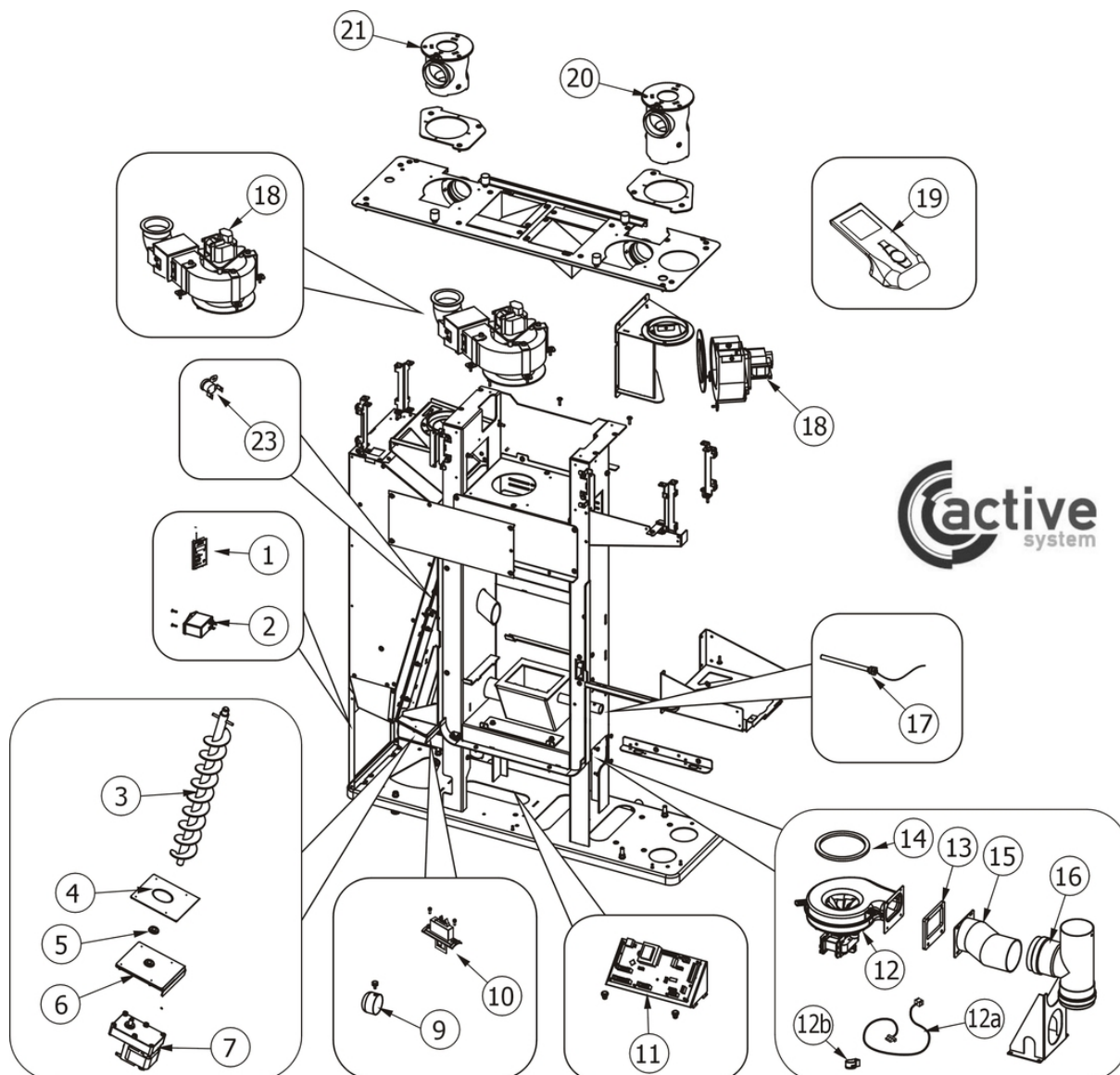

N°	Codice/Code	Descrizioni / Description / Beschreibung / Description / Descripción
1	41450900700	Pannello di emergenza / Emergency panel / Notfalldisplay / Tableau de secours / Panel d'emergencia
1	41450902500	Cavo flat / Flat cable / Flat-Kabel / Cable flat / Cable flat
1	41801499750	Kit 868 / Kit 868 / Kit 868 / Kit 868 / Kit 868
2	4160459	Pulsante accensione / On/Off button / Zündungstaste / Touche d'allumage / Botón encendido
3	41201105240	Coclea di caricamento pellet / Pellet feed screw / Pelletsförderschnecke / Vis sans fin pour chargement du pellet / Cóclea de carga pellet
4	4120615	Guarnizione base della coclea / Feed screw base gasket / Dichtung Untergestell der Förderschnecke / Joint pour la base de la vis sans fin / Junta base de la cóclea
5	4120614	Boccola grafitata (2 pz) / Etched bush (2 pcs) / Graphitbuchse (2 Stck) / Bride graphitée (2 pcs) / Brida grafitada (2 pz)
6	41400944351	Base della coclea / Feed screw base / Untergestell der Förderschnecke / Base de la vis sans fin / Base de la cóclea
7	4160278	Motorriduttore 1,5 RPM / Reduction motor 1,5 RPM / Getriebemotor 1,5 RPM / Motorréducteur 1,5 TPM / Motorreductor 1,5 RPM
9	41401036100	Filtro antipolvere / Anti-dust filter / Staubschutzfilter / Filtre antipoussière / Filtro de protección polvo

10	41451205000	Sensore aria completo / Complete air sensor / Kompletter Luftfühler / Capteur air complet / Sensor aire completo
11	41450907601	Scheda madre / Motherboard / Hauptplatine / Carte mère / Tarjeta madre
11	41801499750	Kit 868 / Kit 868 / Kit 868 / Kit 868 / Kit 868
12	41451003202	Ventilatore aspirazione fumi / Smoke exhausted fan / Rauchabsauggebläse / Ventilateur aspiration fumées / Ventilador aspiración humos
12	41450901800	Sonda fumi Active System / Smoke sensor Active System / Rauchgasfühler ACTIVE SYSTEM / Sonde fumées ACTIVE SYSTEM / Sonda humos Active System
12	41801102500	Guarnizione / Gasket / Dichtung / Joint / Junta
12a	4160477	Cavo ENCODER / ENCODER cable / Drehzahlmesser-kabel / Câble ENCODER / Cable ENCODER
12b	41451209300	Encoder per ventilatore fumi marchi LN2/SIT / Encoder for LN2/SIT smoke fan / Encoder für LN2/SIT Rauchgasgebläse / Encoder pour ventilateur des fumées marques LN2/SIT / Encoder para ventilador humos marcas LN2/SIT
13	418008030	Guarnizione / Gasket / Dichtung / Joint / Junta
14	41801002600	Guarnizione adesiva voluta fumi / Adhesive gasket smoke volute / Haftendichtung Rauchvolute / Joint adhesive volute fumées / Junta adhesiva voluta humos
14	41801599850	Kit 50 guarnizioni / Kit 50 gaskets / Bausatz 50 Dichtungen / Kit 50 joints / Kit 50 juntas
15	41601101860	Tubo uscita fumi / Smoke outlet pipe / Rohr Rauchabzug / Tuyau sortie fumées / Tubo salida humos
16	41601100250	Raccordo a "T" completo / Complete "TEE" union / Komplettes T-Anschlussstück / Raccord complet en "T" / Racor "T" completo
17	41450902600	Candeletta accensione pellet / Pellet ignition sparkplug / Zündkerze Pelletzündung / Bougie d'allumage pellet / Bujía encendido pellet
17	41801599450	Kit 50 candelette / 50 Sparkplugs Kit / Bausatz 50 Zündkerzen / Kit 50 Bougies / Kit 50 Bujías
18	41451002903	Motore ventilatore portata 170 m3/h / Fan motor capacity 170 m3/h / Gebläsemotor Leistung 170 m3/h / Moteur ventilateur débit 170 m3/h / Motor ventilador caudal 170 m3/h
18	41451002903	Motore ventilatore portata 170 m3/h / Fan motor capacity 170 m3/h / Gebläsemotor Leistung 170 m3/h / Moteur ventilateur débit 170 m3/h / Motor ventilador caudal 170 m3/h
19	41450901500	Telecomando / Remote control / Fernbedienung / Télécommande / Mando a distancia
19	41451106000	Telecomando / Remote control / Fernbedienung / Télécommande / Mando a distancia
19	41801499750	Kit 868 / Kit 868 / Kit 868 / Kit 868 / Kit 868
20	41401143340	Convogliatore rotante DX lungo / Long right rotating woben-wire / Langer RE. drehender Vörderer / Convoyeur tournant droit long / Conductor rotatorio DCHO largo
21	41401144340	Convogliatore rotante SX corto / Short left rotating woben-wire / Kurzer LI. drehender Vörderer / Convoyeur tournant gauche court / Conductor rotatorio IZDO corto
23	412007004	Clickson 110°C / Clickson 110°C / Clickson 110°C / Clickson 110°C / Clickson 110°C