

TOBA AIR

Componenti Struttura Esterna / External structure components / Bauteile Aussenkorpus / Composants structure externe / Componentes estructura externa

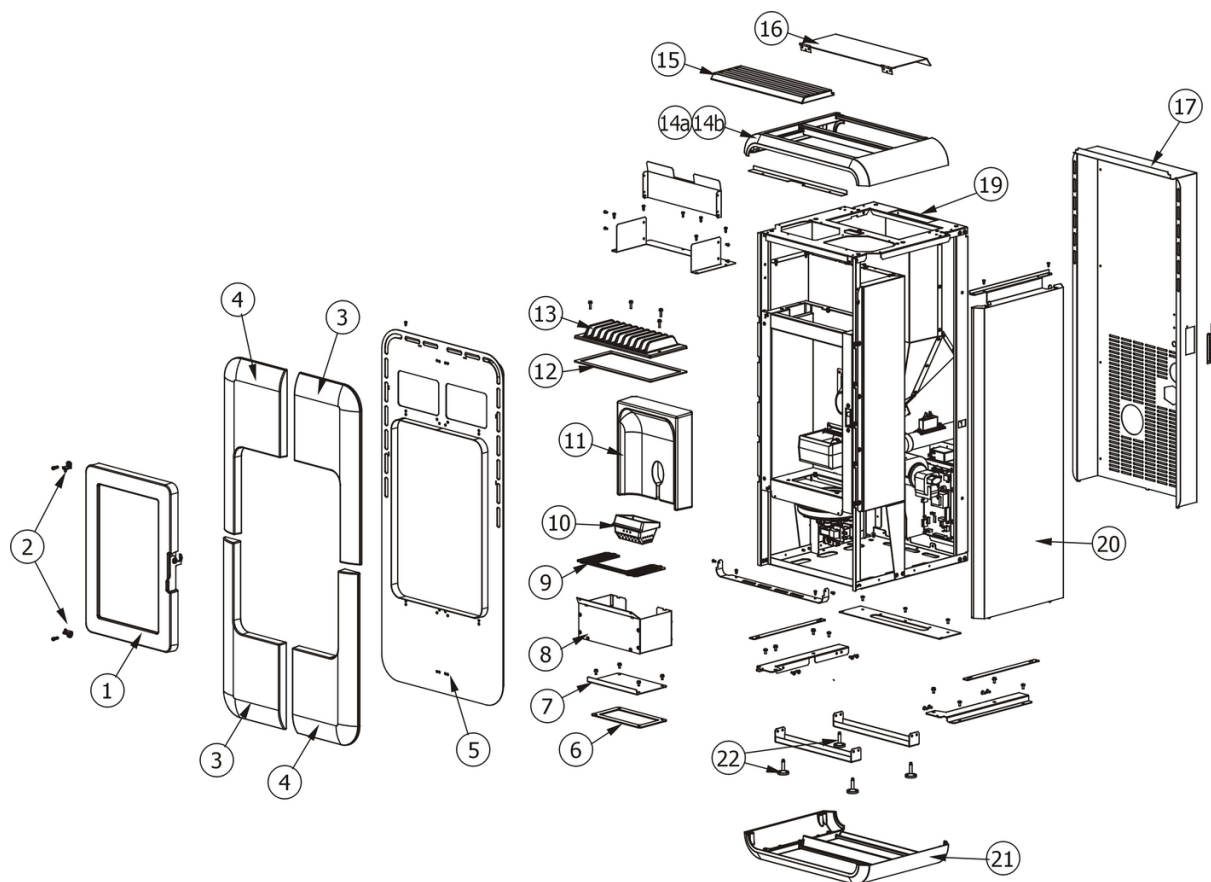

N°	Codice/Code	Descrizioni / Description / Beschreibung / Description / Descripcion
1	41300901550	Porta completa / Complete door / Komplette Tür / Porte complète / Puerta completa
2	412008063	Cerniere porta fuoco (2 pz) / Fire door hinge (2pcs) / Scharnier Feuertür (2 Stck) / Charnière porte foyer (2 pcs) / bisagra puerta del hogar (2 pz)
3	41250913150	Ceramica sup. DX ed inf. SX White / White upper R. and lower L. ceramic / Obere RE. und unten LI. White Keramik / Céramique sup. D et inf. G. white / Cerámica sup. DCHA e inf. IZDA white
3	41250913250	Ceramica sup. Dx ed inf. Sx RED / RED upper RI. and lower LE. ceramic / Obere RE. und unten LI. RED Keramik / Céramique sup. D. et inf. G. RED / Cerámica sup. DCHA e inf. IZDA RED
3	41250913350	Ceramica sup. Dx ed inf. Sx bordeaux / Burgundy upper R. and lower L. ceramic / Obere RE. und unten LI. Keramik bordeaux / Céramique sup. D. et inf. G. bordeaux / Cerámica sup. DCHA e inf. IZDA burgundi
3	41250913450	Ceramica sup. Dx ed inf. Sx Black / Black upper R. and lower L. ceramic / Obere RE. und unten LI. Black Keramik / Céramique sup. D. et inf. G. black / Cerámica sup. DCHA e inf. IZDA black
3	41250913550	Ceramica sup. DX ed inf. SX Skin / Skin upper R. and lower L. ceramic / Obere RE. und unten LI. Skin Keramik / Céramique sup. D et inf. G. Skin / Cerámica sup. DCHA e inf. IZDA Skin
3	41250913550	Ceramica sup. DX ed inf. SX Skin / Skin upper R. and lower L. ceramic / Obere RE. und unten LI. Skin Keramik / Céramique sup. D et inf. G. Skin / Cerámica sup. DCHA e inf. IZDA Skin
3	41250914150	Soapstone sup. DX ed inf. SX / Upper R. and lower L. Soapstone / Ober Re. und unten LI. Soapstone / Soapstone sup. D. et inf. G. / Soapstone sup. DCHA e inf. IZDA
3	41251103850	Ceramica sup. DX ed inf. SX Sandstone / Sandstone upper R. and lower L. ceramic / Obere RE. und unten LI. Keramik Sandstone / Céramique sup. D et inf. G. Sandstone / Cerámica sup. DCHA e inf. IZDA Sandstone
3	41251103850	Ceramica sup. DX ed inf. SX Sandstone / Sandstone upper R. and lower L. ceramic / Obere RE. und unten LI. Keramik Sandstone / Céramique sup. D et inf. G. Sandstone / Cerámica sup. DCHA e inf. IZDA Sandstone
4	41250912150	Ceramica sup. Sx ed inf. Dx white / White upper L. LEFT and lower R. ceramic / Ober LI. und unten RE White Keramik / Céramique sup. G. et inf. D. white / Cerámica sup. IZDA e inf. DCHA white
4	41250912250	Ceramica sup. Sx ed inf. Dx red / Red upper L. and lower R. ceramic / Ober LI. und unten RE. Red Keramik / Céramique sup. G. et inf. D. red / Cerámica sup. IZDA e inf. DCHA red
4	41250912350	Ceramica sup. SX ed inf. DX - BORDEAUX / Upper ceramic LEFT and lower RIGHT - BORDEAUX / Obere Keramik

		LI. und unten RE. - BORDEAUX / Céramique sup. GAUCHE et inf. DROITE - BORDEAUX / Cerámica sup. IZDA e inf. DCHA - BORDEAUX
4	41250912450	Ceramica sup. SX ed inf. DX - BLACK / Upper ceramic LEFT and lower RIGHT - BLACK / Obere Keramik LI. und unten.RE. - BLACK / Céramique sup. GAUCHE et inf. DROITE - BLACK / Cerámica sup. IZDA e inf. DCHA - BLACK
4	41250912550	Ceramica sup. Sx ed inf. Dx Skin / Skin upper L. LEFT and lower R. ceramic / Ober LI. und unten RE. Skin Keramik / Céramique sup. G. et inf. D. Skin / Cerámica sup. IZDA e inf. DCHA Skin
4	41250912550	Ceramica sup. Sx ed inf. Dx Skin / Skin upper L. LEFT and lower R. ceramic / Ober LI. und unten RE. Skin Keramik / Céramique sup. G. et inf. D. Skin / Cerámica sup. IZDA e inf. DCHA Skin
4	41250914050	Soapstone sup. Sx ed inf. Dx / Upper L. and lower R. soapstone / Ober LI. und unten. RE. Soapstone / Soapstone sup. G. et inf. D. / Soapstone sup. IZDA e inf. DCHA
4	41251103750	Ceramica sup. Sx ed inf. Dx Sandstone / Sandstone upper L. LEFT and lower R. ceramic / Ober LI. und unten RE Keramik Sandstone / Céramique sup. G. et inf. D. Sandstone / Cerámica sup. IZDA e inf. DCHA Sandstone
4	41251103750	Ceramica sup. Sx ed inf. Dx Sandstone / Sandstone upper L. LEFT and lower R. ceramic / Ober LI. und unten RE Keramik Sandstone / Céramique sup. G. et inf. D. Sandstone / Cerámica sup. IZDA e inf. DCHA Sandstone
5	41400945360	Telaio in acciaio nero / Black steel frame / Rahmen aus schwarzem Stahl / Cadre en acier noir / Marco en acero negro
6	418008025	Guarnizione / Gasket / Dichtung / Joint / Junta
6	4180080251	Kit 50 guarnizioni / Kit 50 gaskets / Bausatz 50 Dichtungen / Kit 50 joints / Kit 50 juntas
7	41400906330V	Tappo ispezione vano fumi / Smoke compartment inspection plug / Inspektionsdeckel Rauchabzug / Clapet inspection compartiment fumées / Tapón inspección compartimento humos
8	41400906431V	Cassetto cenere / Ash drawer / Aschenkasten / Tiroir à cendres / Cajón ceniza
9	41400906610V	Griglia focolare / Fire box grille / Feuerstellenrost / Grille foyer / Rejilla hogar
10	413008003	Braciere completo in ghisa / Cast iron complete grate / Kompletter Brennertopf aus Gusseisen / Brasero complet en fonte / Brasero completo de arrabio
11	43650151	Schiena in Alutec® / Alutec® back / Rückwand aus Alutec® / Fond en Alutec® / Parte trasera en Alutec®
12	41800802600	Kit 50 guarnizioni / Kit 50 gaskets / Bausatz 50 Dichtungen / Kit 50 joints / Kit 50 juntas
12	41800802601	Guarnizione / Gasket / Dichtung / Joint / Junta
13	41300901100	Scambiatore in ghisa / Cast iron exchanger / Gusseiserne Wärmetauscher / Echangeur en fonte / Intercambiador en arrabio
14a	41310900160	Top in acciaio nero verniciato / Black painted steel top / Abdeckplatte aus Stahl Schwarz lackiert / Dessus en acier laqué noir / Top en acero negro barnizado
14b	41310900150	Top in acciaio / Steel top / Abdeckplatte aus Edelstahl / Dessous en acier / Top en acero
15	41310900260	Griglia uscita aria calda / Hot air outlet grille / Gitter Wärmeluftaustritt / Grille sortie air chaud / Rejilla salida aire caliente
16	41400945960	Coperchio serbatoio pellet / Pellet hopper cover / Deckel Pelletbehälter / Couvercle réservoir pellet / Tapa depósito pellet
17	41400945661	Schiena esterna in acciaio / Steel external back / Aussenrückwand aus Stahl / Fond extérieur en acier / Panel trasero externo en acero
19	41400904962	TOP in acciaio nero verniciato / Steel TOP painted black / ABDECKPLATTE in Stahl schwarz lackiert / DESSUS en acier laqué noir / TOP de acero negro barnizado
20	41400946060	Laterale DX-SX in acciaio / R.-L. steel side / RE.-LI. Stahlausseite / Côté D.-G. en acier / Lateral acero DCHO-IZDO
21	41310900660	Base in acciaio nero verniciato / Black painted base / Basis aus Stahl Schwarz lackiert / Base en acier laqué noir / Base en acero negro barnizado
22	4120618	Piedini di appoggio (4 pz) / Support feet (4 pcs) / Einstellfüße (4 Stck) / Vérins d'appui (4 pcs) / Pies de apoyo (4 pz)

TOBA AIR

Porta fuoco / Fire door / Feuertür / Porte foyer / Puerta hogar

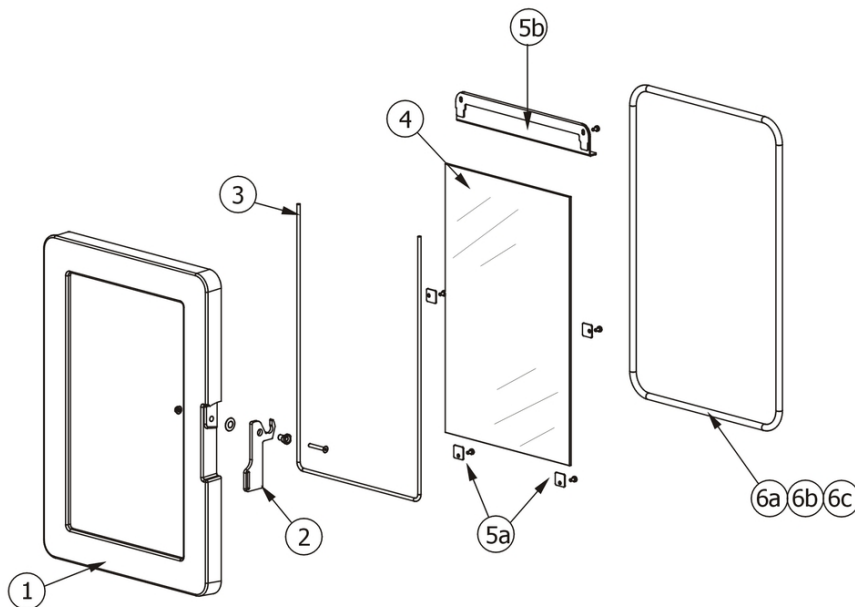

N°	Codice/Code	Descrizioni / Description / Beschreibung / Description / Descripción
1	41300901500V	Telaio porta in ghisa / Cast iron door frame / Türrahmen aus Gusseisen / Cadre porte en fonte / Marco puerta en arrabio
2	41400939760	Maniglia completa / Complete handle / Kompletter Griff / Poignée complète / Tirador completo
3	4120106	Guarnizione a nastro fireglass / Fireglass tape gasket / Banddichtung Fireglass / Joint ruban Fireglass / Guarnición a cinta Fireglass
4	41700901060	Vetroceramico completo di guarnizione / Glass with gasket / Glaskeramikscheibe mit Dichtung / Vitrocéramique avec joint / Cristal cerámico con guarnición
5a	41401077430	Staffe di fissaggio vetroceramico (4 pz.) / Pyroceram fastening brackets (4 pcs.) / Befestigungsbügel Glaskeramik (4 Stck.) / Étrier de fixation vitrocéramique (4 pz.) / Abrazaderas de fijación vidrio cerámico (4 piezas)
5b	41400939630V	Deflettore porta / Door deflector / Leitblech der Tür / Déflecteur de la porte / Deflector de la puerta
6a	4120103A	Cordino fibroceramico Ø 10 mm (5 mt.) / Ceramic fibre cord Ø 10 mm (5 m) / Keramikfaserschnur Ø 10 mm (5 m) / Cordon en fibre céramique Ø 10 mm (5 m) / Junta a cuerda de fibra cerámica Ø 10 mm (5 m)
6b	4120103B	Cordino fibroceramico Ø 10 mm (50 mt.) / Ceramic fibre cord Ø 10 mm (50 m) / Keramikfaserschnur Ø 10 mm (50 m) / Cordon en fibre céramique Ø 10 mm (50 m) / Junta a cuerda de fibra cerámica Ø 10 mm (50 m)
6c	41201031	Kit sostituzione cordino (cordino+silicone) Ø 10 mm / Cord replacement kit (cord + silicon) Ø 10 mm / Schnuraustauschsatz (Schnur+Silikon) Ø 10 mm / Kit remplacement cordon (cordon + silicone) Ø 10 mm / Kit sustitución junta a cuerda (junta a cuerda+silicón) Ø 10 mm

TOBA AIR

Componenti interni meccanici ed elettronici / Electronic and mechanic internal parts / Interne mechanische und elektronische Bauteile / Composants internes mécaniques et électroniques / Componentes internos electrónicos y mecánicos

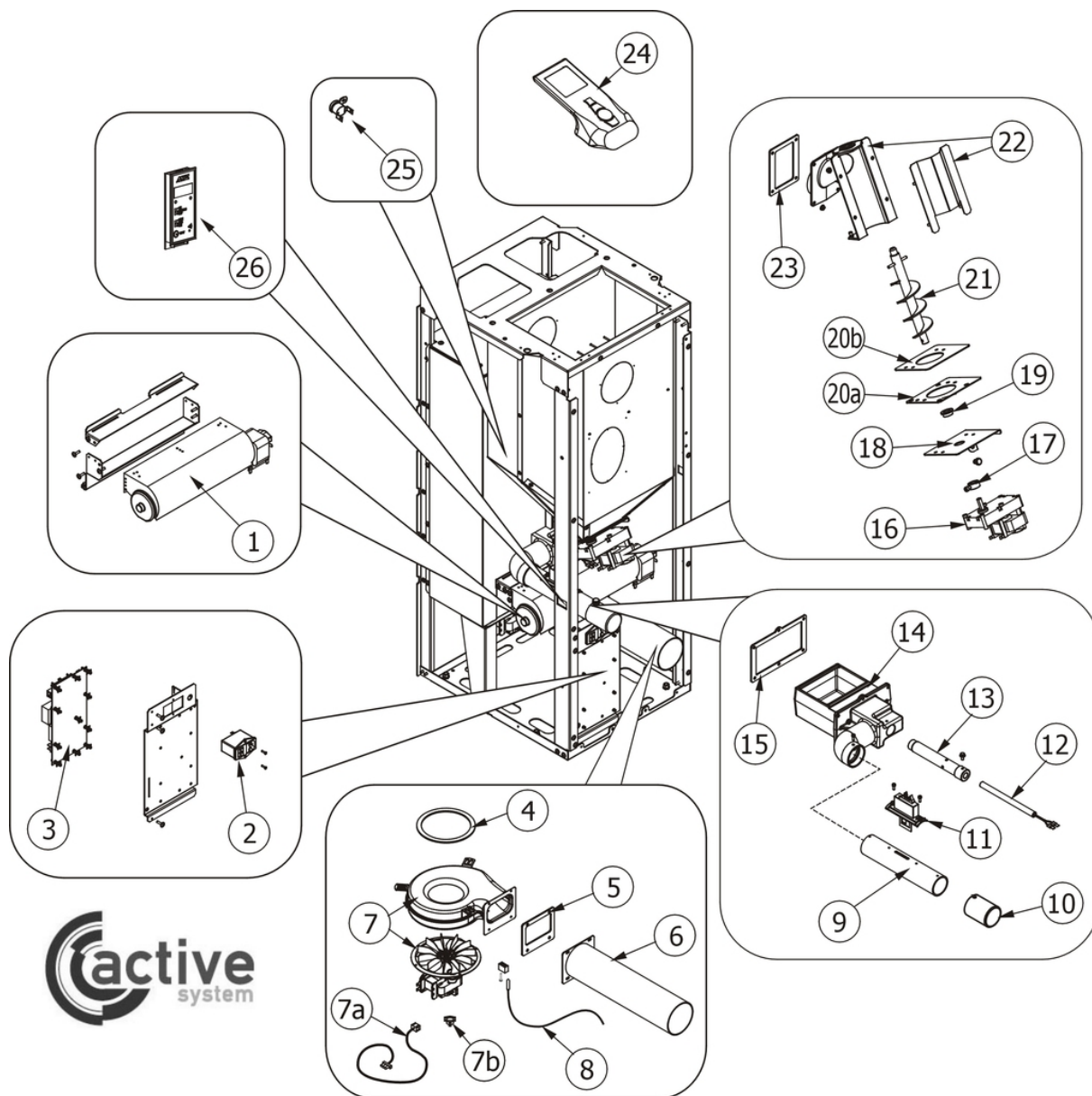

N°	Codice/Code	Descrizioni / Description / Beschreibung / Description / Descripción
1	41451002800	Ventilatore aria calda / Warm air fan / Warmluftgebläse / Ventilateur air chaud / Ventilador aire caliente
2	4160459	Pulsante accensione / On/Off button / Zündungstaste / Touche d'allumage / Botón encendido
3	41450907601	Scheda madre / Motherboard / Hauptplatine / Carte mère / Tarjeta madre
3	41801499750	Kit 868 / Kit 868 / Kit 868 / Kit 868 / Kit 868
4	41801002600	Guarnizione adesiva voluta fumi / Adhesive gasket smoke volute / Haftendichtung Rauchvolute / Joint adhesive volute fumées / Junta adhesiva voluta humos
4	41801599850	Kit 50 guarnizioni / Kit 50 gaskets / Bausatz 50 Dichtungen / Kit 50 joints / Kit 50 juntas
5	418008030	Guarnizione / Gasket / Dichtung / Joint / Junta
6	416008010	Tubo uscita fumi / Smoke outlet pipe / Rohr Rauchabzug / Tuyau sortie fumées / Tubo salida humos
7	41451003202	Ventilatore aspirazione fumi / Smoke exhausted fan / Rauchabsauggebläse / Ventilateur aspiration fumées / Ventilador aspiración humos
7	41801102500	Guarnizione / Gasket / Dichtung / Joint / Junta

7a	4160477	Cavo ENCODER / ENCODER cable / Drehzahlmesser kabel / Câble ENCODER / Cable ENCODER
7b	41451209300	Encoder per ventilatore fumi marchi LN2/SIT / Encoder for LN2/SIT smoke fan / Encoder für LN2/SIT Rauchgasgebläse / Encoder pour ventilateur des fumées marques LN2/SIT / Encoder para ventilador humos marcas LN2/SIT
8	41450901800	Sonda fumi Active System / Smoke sensor Active System / Rauchgasfühler ACTIVE SYSTEM / Sonde fumées ACTIVE SYSTEM / Sonda humos Active System
9	41200901200	Tubo ingresso aria / Air inlet pipe / Luftergangsrohr / Tuyau entrée air / Tubo entrada aire
10	41401036100	Filtro antipolvere / Anti-dust filter / Staubschutzfilter / Filtre antipoussière / Filtro de protección polvo
11	41451205000	Sensore aria completo / Complete air sensor / Kompletter Luftfühler / Capteur air complet / Sensor aire completo
12	41450905000	Candeletta accensione pellet / Pellet ignition sparkplug / Zündkerze Pelletzündung / Bougie d'allumage pellet / Bujía encendido pellet
12	41801599550	Kit 50 candelette / 50 Sparkplugs kit / Bausatz 50 Zündkerzen / Kit 50 Bougies / Kit 50 Bujías
13	41200903900	Condotto candeletta / Sparkplug conduit / Zündkerzenkanal / Conduit bougie / Conducto bujía
14	414008043	Tasca braciere in ghisa / Combustion pot container / Brenntopfkasten aus Gusseisen / Récipient braséro / Contenedor brasero
14	41401069141V	Tasca braciere / Combustion pot container / Brenntopfkasten / Récipient braséro / Contenedor brasero
15	418008027	Guarnizione / Gasket / Dichtung / Joint / Junta
16	4160278	Motoriduttore 1,5 RPM / Reduction motor 1,5 RPM / Getriebemotor 1,5 RPM / Motorréducteur 1,5 TPM / Motorreductor 1,5 RPM
17	4120398	Connettore motoriduttore-coclea / Reduction motor-feed screw connector / Verbindung Getriebemotor-Schnecke / Connecteur motorréducteur-vis sans fin / Conector motorreductor-cóclea
18	41400944351	Base della coclea / Feed screw base / Untergestell der Förderschnecke / Base de la vis sans fin / Base de la cóclea
19	4120614	Boccola grafitata (2 pz) / Etched bush (2 pcs) / Graphitbuchse (2 Stck) / Bride graphitée (2 pcs) / Brida grafitada (2 pz)
20a	4120615	Guarnizione base della coclea / Feed screw base gasket / Dichtung Untergestell der Förderschnecke / Joint pour la base de la vis sans fin / Junta base de la cóclea
20b	41400903310	Flangia condotto coclea / Base of feed screw conduit / Untergestell Rohrleitung der Förderschnecke / Base du conduit de la vis sans fin / Base de conducto de la cóclea
21	41200901040	Coclea di caricamento pellet / Pellet feed screw / Pelletsförderschnecke / Vis sans fin pour chargement du pellet / Cóclea de carga pellet
22	41401077540V	Condotto della coclea / Conduit of feed screw / Rohrleitung der Förderschnecke / Conduit de la vis sans fin / Conducto de la cóclea
24	41450901500	Telecomando / Remote control / Fernbedienung / Télécommande / Mando a distancia
24	41451106000	Telecomando / Remote control / Fernbedienung / Télécommande / Mando a distancia
24	41801499750	Kit 868 / Kit 868 / Kit 868 / Kit 868 / Kit 868
23	418008029	Guarnizione / Gasket / Dichtung / Joint / Junta
25	412007004	Clickson 110°C / Clickson 110°C / Clickson 110°C / Clickson 110°C / Clickson 110°C
26	41450900700	Pannello di emergenza / Emergency panel / Notfalldisplay / Tableau de secours / Panel d'emergencia
26	41450902500	Cavo flat / Flat cable / Flat-Kabel / Cable flat / Cable flat
26	41801499750	Kit 868 / Kit 868 / Kit 868 / Kit 868 / Kit 868