

RAAM COMFORT AIR 8 S1

Gruppo estetico / Aesthetic group / Aesthetische Gruppe / Groupe esthétique / Grupo estético

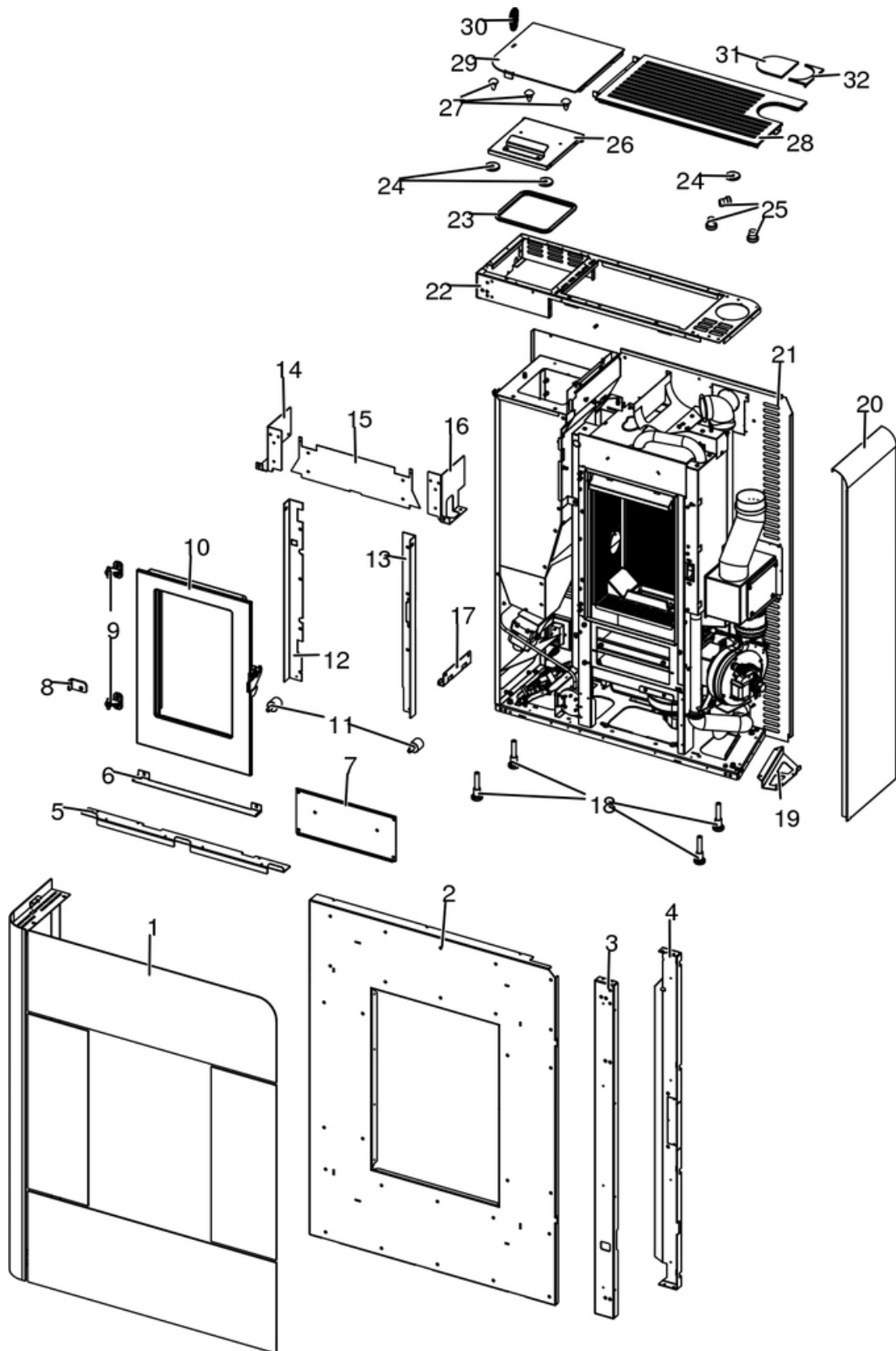

N°	Codice/Code	Descrizioni / Description / Beschreibung / Description / Descripcion
1	6918005	Rivestimento metallo White / Metal cladding White / Metallverkleidung White / Habillage metal White / Revestimiento metal White
1	6918006	Rivestimento metallo Dark / Metal cladding Dark / Metallverkleidung Dark / Habillage metal Dark / Revestimiento metal Dark
1	6918007	Rivestimento metallo Silver / Metal cladding Silver / Metallverkleidung Silver / Habillage metal Silver / Revestimiento metal Silver
1	6918008	Rivestimento metallo Bordeaux / Metal cladding Bordeaux / Metallverkleidung Bordeaux / Habillage metal Bordeaux / Revestimiento metal Bordeaux
2	4141184504000	Telaio frontale / Front frame / Vorderer Rahmen / Cadre frontal / Armazón frontal
3	41401727231	Montante anteriore / Frontal upright / Vorderaufrecht / Droit frontal / Vertical delantero
4	41401710930	Montante / Upright / Aufrecht / Droit / Vertical
5	41401806730	Supporto frontale / Frontal support / Vorderstuezte / Support frontal / Soporte frontal
6	4141184653000	Sottoporta / Door protection / Schutz unter der Tür / Protection sous porte / Resguardo abajo puerta
7	437018076	Tappo cenere / Ash cap / Asche Verschluss / Bouchon cendre / Tapón ceniza
7	4120573A	Guarnizione a nastro 8 mm (5 mt.) per porta / Door strip gasket 8 mm (5 m) / Türbanddichtung 8 mm (5 m) / Joint ruban 8 mm (5 m) pour porte / Guarnición de cinta para puerta 8 mm (5 m)
7	4120573B	Guarnizione a nastro 8 mm (50 mt.) per porta / Door strip gasket 8 mm (50 m) / Türbanddichtung 8 mm (50 m) / Joint ruban 8 mm (50 m) pour porte / Guarnición de cinta para puerta 8 mm (50 m)
8	4141184413000	Blocco porta ghisa / Door stop cast iron / Türstopper Guß / Stop pour porte fonte / Tope por puerta arrabio
9	41201504460	Cerniera porta (2 pz.) / Door hinge (2 pc.) / Tür Scharnier (2 Stk.) / Charnière porte (2 pc.) / Bisagra puerta (2)
10	437018069	Porta focolare / Fireplace door / Feuerstelle Tür / Porte foyer / Puerta hogar
11	41201105600	Antivibranti (10 pz) / anti-vibration mountings (10 pcs) / Schwingungsdämpfer (10 Stck) / Éléments antivibratoires (10 pcs) / Anti-vibraciones (10 pz)
12	4141184663100	Profilo interno / Internal profile / Innenprofil / Profil interieur / Perfile interno
13	4141184683100	Profilo interno dx / Internal profile R. / Innenprofil R. / Profil interieur D. / Perfile interno DCHA
14	4141185553000	Tamponazione sx / Filler L. / Stopfung L. / Tampon G. / Taponado IZDO
15	41401813210	Tamponazione anteriore / Frontal filling / Vorderabdichtung / Tampon frontal / Taponado frontal
16	4141184463000	Tamponazione / Filler / Stopfung / Tampon / Taponado
17	41401806530	Supporto fianco dx / Support R. side / Stütze Seiten R. / Support côté D. / Soporte lado DCHO
18	41200906660	Piedini di appoggio (4 pz.) / Support feet (4 pcs.) / Einstellfüße (4 Stck.) / Vérins d'appui (4 p.es) / Pies de apoyo (4 piezas)
19	41401721030	Supporto fianco dx / Support R. side / Stütze Seiten R. / Support côté D. / Soporte lado DCHO
20	4141184564000	Fianco dx / R. side / Seite R. / Côté D. / Lateral DCHO
21	41401806831	Schiena posteriore / Back / Hintere Rückwand / Dossieret postérieur / Parte trasera
22	4141184473000	Supporto top / Top support / Deckelhalbteügel / Support du dessus / Soporte del top
23	41801604700	Guarnizione tenuta serbatoio / Pellet hopper gasket / Pelletbehälter Dichtung / Joint réservoir pellet / Junta depósito pellet
24	41801657900	Magneti (pz.2) / Magnet (pcs.2) / Magnet (stk. 2) / Aimant (pcs.2) / Imán (pz.2)
25	4120180	Gommini paracolpi (4 pz) / Rubber bumpers (4 pcs.) / Schlagschutzgummi (4 Stck) / Pièces caoutchouc antichoc (4 pcs) / Cauchitos anti-golpes (4 pz)
26	41401714650	Coperchio tecnico / Technical cover / Technicher Deckel / Couvercle technique / Tapadera técnica
27	41801002300	Paracolpi in silicone Ø 8/5 (2pz) / Silicone bumpers Ø 8/5 (2pcs) / Schlagschutzgummi Ø 8/5 (2 Stck) / Pièces silicone antichoc Ø 8/5 (2pcs) / Anti-golpes en silicona Ø 8/5 (2pzs)
28	4141184444000	Top / Top / Abdeckplatte / Dessous / Top
29	4141184434000	Coperchio / Cover / Deckel / Couvercle / Tapa
30	41801602200	Maniglia silconica / silicone handle / Silikongriff / Poignée de silicone / Tirador de silicona
31	4141184514000	Tappo / Plug / Stopfen / Bouchon / Tapón
32	4141184524000	Tappo / Plug / Stopfen / Bouchon / Tapón

RAAM COMFORT AIR 8 S1

Gruppo camera di combustione / Combustion chamber group / Verbrennungskammer Gruppe / Group de chambre de combustion / Grupo cámara de combustión

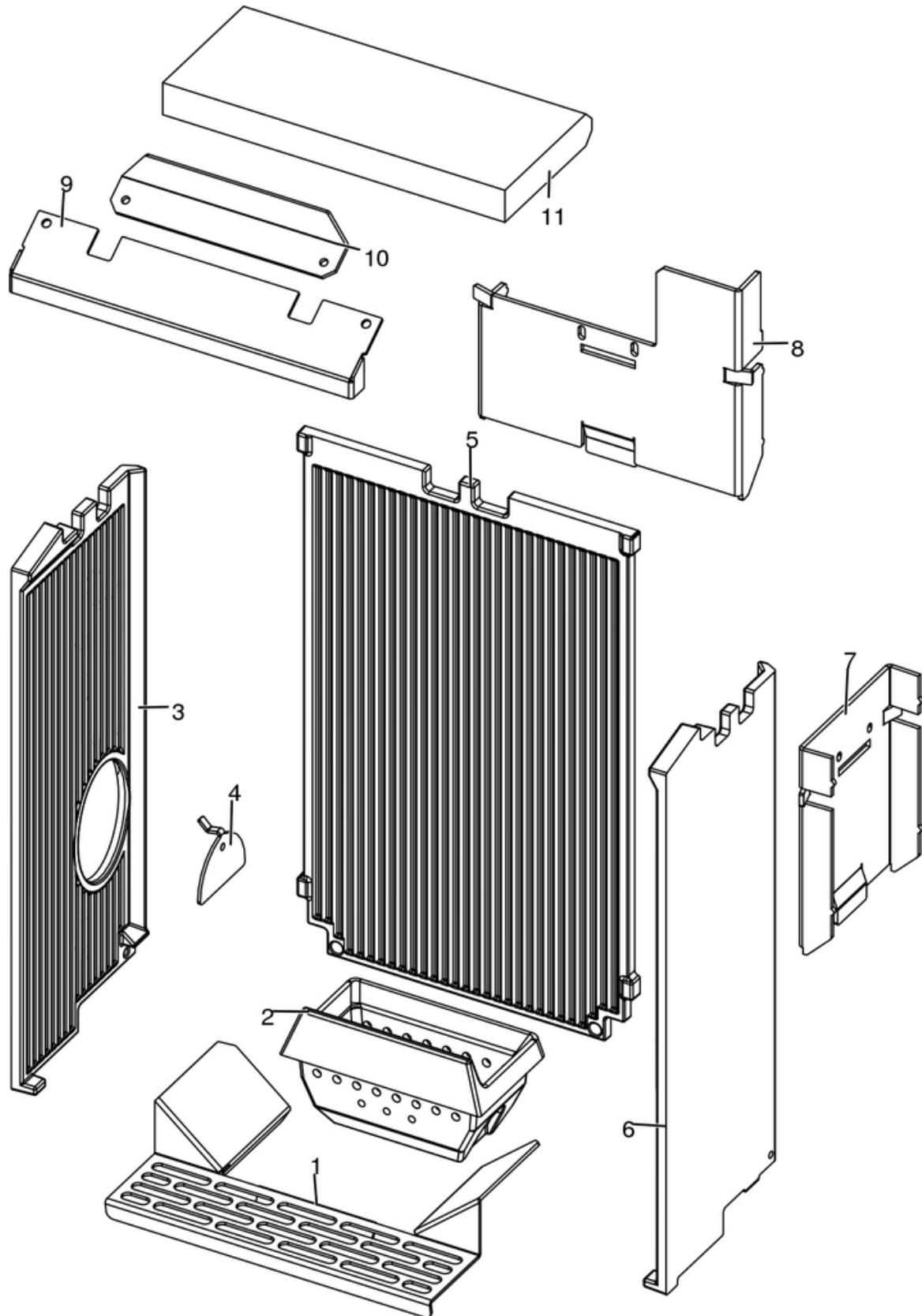

N°	Codice/Code	Descrizioni / Description / Beschreibung / Description / Descripción
1	41411742230V	Griglia focolare / Fire box grille / Feuerstellenrost / Grille foyer / Rejilla hogar
2	4130170030100	Braciere ghisa / Cast iron brazier / Brennschale aus Guß / Brasero en fonte / Brasero de arrabio
3	41301700600V	Fianco sinistro in ghisa / Left cast iron side / Linke Seite aus Guß / Coté gauche en fonte / Placa lateral izquierda de arrabio
4	41411613530V	Deflettore pellet / Pellet deflector / Pellet Leitblech / Deflecteur pellet / Deflector pellet
5	41301700700V	Schiena in ghisa / Cast iron back / Rückwand aus Guß / Fond en fonte / Parte trasera de arrabio
6	41301700500V	Fianco destro in ghisa / Right cast iron side / Rechte Seite aus Guß / Coté droit en fonte / Placa lateral derecha de arrabio
7	41411740231	Tappo lat. pulizia struttura / Lateral cap for structure cleaning / Seitlicher Stöpsel für Korpus Reinigung / Bouchon lateral pour nettoyage structure / Tapon lateral por limpieza estructura
8	41411740131	Tappo post. pulizia struttura / Rear cap for structure cleaning / Hinterer Stöpsel für Korpus Reinigung / Bouchon postérieur pour nettoyage structure / Tapon posterior por limpieza estructura
9	4141174234200	Deflettore pulizia vetro / Deflector for glass cleaning / Leitblech für Glassreinigung / Deflecteur pour nettoyage / Deflector por limpieza vidrio
10	41331702031	Protezione focolare inox / Inox fire protection / Feuerschutz aus Edelstahl / Protection foyer inox / Protección hogar inox
11	41151702000	Deflettore vermiculite / Vermiculite deflector / Leitblech aus Vermiculite / Défecteur en vermiculite / Deflector en vermiculite

RAAM COMFORT AIR 8 S1

Porta fuoco / Fire door / Feuertür / Porte foyer / Puerta hogar

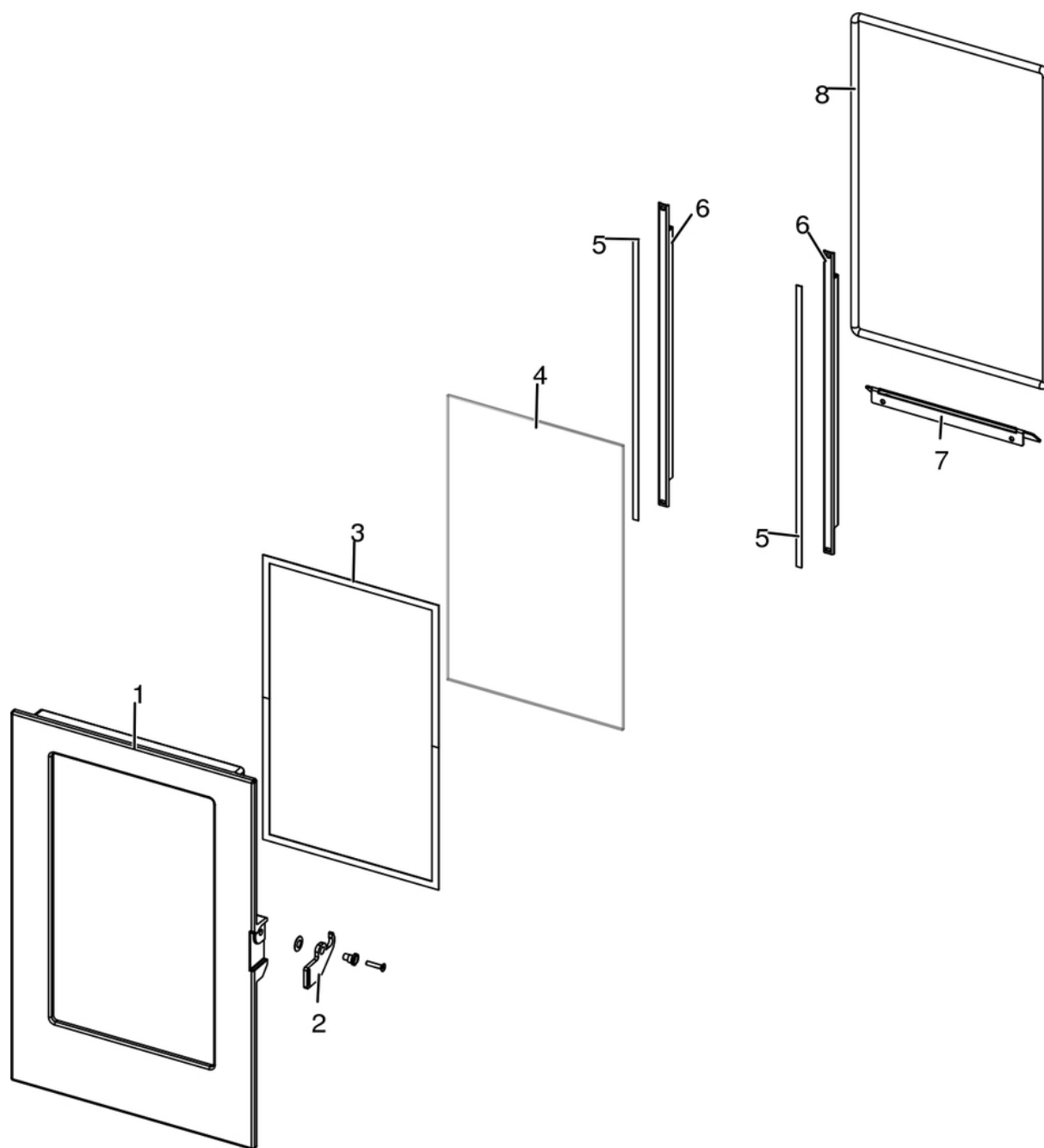

N°	Codice/Code	Descrizioni / Description / Beschreibung / Description / Descripción
1	4130170370000	Porta in ghisa / Cast iron door / Tür aus Gusseisen / Porte en fonte / Puerta de arrabio
2	41411844261	Maniglia porta / Door Handle / Türgriff / Poignée porte / Tirador
3	41801603300A	Guarnizione Ø5 5mt / Gasket Ø5 5mt / Dichtung Ø5 5mt / Joint Ø5 5mt / Junta Ø5 5mt
3	41801603300B	Guarnizione Ø5 50mt / Gasket Ø5 50mt / Dichtung Ø5 50mt / Joint Ø5 50mt / Junta Ø5 50mt
3	41801603300C	Guarnizione Ø5 5mt + silicone / Gasket Ø5 5mt + silic / Dichtung Ø5 5mt + Silikon / Joint Ø5 5mt + silic / Junta Ø5 5mt
4	41701701800	Vetroceramico porta tecnica / Technical door glass / Glas für technische Tür / Vitrocéramique porte technique / Cristal cerámico puerta técnica
5	4120573A	Guarnizione a nastro 8 mm (5 mt.) per porta / Door strip gasket 8 mm (5 m) / Türbanddichtung 8 mm (5 m) / Joint ruban 8 mm (5 m) pour porte / Guarnición de cinta para puerta 8 mm (5 m)

5	4120573B	Guarnizione a nastro 8 mm (50 mt.) per porta / Door strip gasket 8 mm (50 m) / Türbanddichtung 8 mm (50 m) / Joint ruban 8 mm (50 m) pour porte / Guarnición de cinta para puerta 8 mm (50 m)
6	4160170440000	Profilo fermavetro / Fastening bracket profile / Haltebügel für Scheibebefestigung Profil / Profil patte de fixation / Perfil fermacristal
7	4141174203200	Scivolo cenere / Ash ramp / Aschenrutsche / Glissèrie cendre / Tobogán ceniza
8	4120104A	Cordino fibroceramico Ø 12 mm (5 mt.) / Ceramic fibre cord Ø 12 mm (5 m.) / Keramikfaserschnur Ø 12 mm (5 m) / Cordon en fibre céramique Ø 12 mm (5 m) / Junta a cuerda de fibra cerámica Ø 12 mm (5 m)
8	4120104B	Cordino fibroceramico Ø 12 mm (50 mt.) / Ceramic fibre cord Ø 12 mm (50 m.) / Keramikfaserschnur Ø 12 mm (50 m) / Cordon en fibre céramique Ø 12 mm (50 m) / Junta a cuerda de fibra cerámica Ø 10 mm (52 m)
8	41201041	Kit sostituzione cordino (cordino+silicone) Ø 12 mm / Cord replacement kit (cord + silicon) Ø 12 mm / Schnuraustauschsatz (Schnur+Silikon) Ø 12 mm / Kit remplacement cordon (cordon + silicone) Ø 12 mm / Kit sustitución junta a cuerda (junta a cuerda+silicón) Ø 12 mm

RAAM COMFORT AIR 8 S1

Gruppo caricamento pellet / Pellet feed group / Pellet Fördergruppe / Groupe chargement du pellet / Grupo de carga pellet

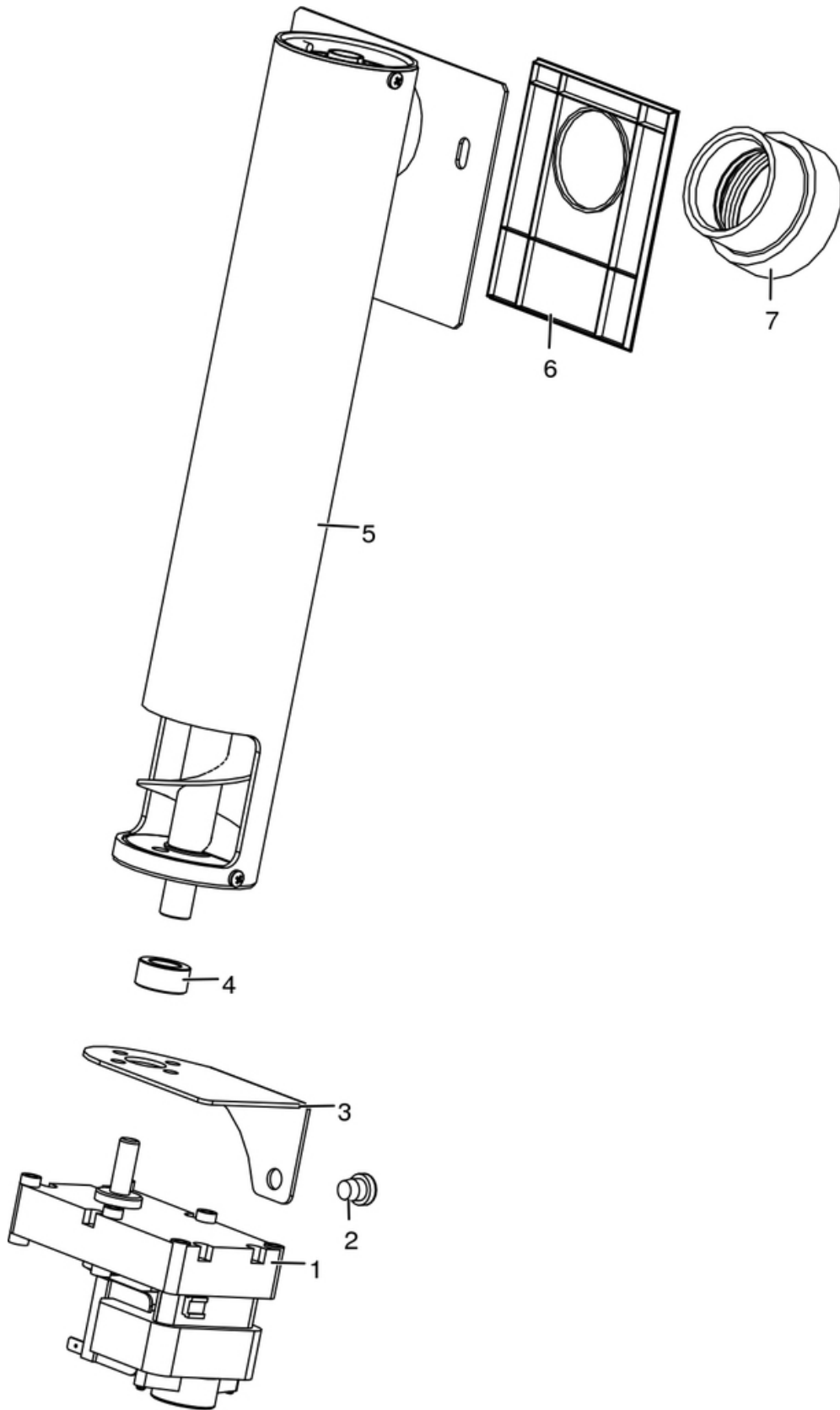

N°	Codice/Code	Descrizioni / Description / Beschreibung / Description / Descripcion
1	41451503100	Motoriduttore 2rpm / Gear motor 2rpm / Getriebemotor 2rpm / Motoréducteur 2rpm / Motorreductor 2rpm
2	4120180	Gommini paracolpi (4 pz) / Rubber bumpers (4 pcs.) / Schlagschutzgummi (4 Stck) / Pièces caoutchouc antichoc (4 pcs) / Cauchitos anti-golpes (4 pz)
3	41401623830	base coclea pellet / Feed screw base for pellet / Untergestell der Förderschnecke für Pellet / Base de la vis sans fin granulé / Base de la cóclea pellets
4	4120398	Connettore motoriduttore-coclea / Reduction motor-feed screw connector / Verbindung Getriebemotor-Schnecke / Connecteur motoréducteur-vis sans fin / Conector motorreductor-cóclea
5	41411741151	Alimentazione completa / Complete power / Komplette Anspeisung / Alimentation complète / Alimentacion completa
6	41801600400	Guarnizione gruppo caricamento / Gasket / Dichtung / Joint / Junta
7	41801702600	Disaccoppiatore mesc. Marrone / Brown disengaging device / Braun Verängungsrohr / Tuyau de découplage maron / Tubo de desvío marron

RAAM COMFORT AIR 8 S1

Gruppo elettrico ed elettronico / Electrical and electronic group / Elektrische und elektronische Gruppe / Groupe électrique et électronique / Grupo eléctrico y electrónico

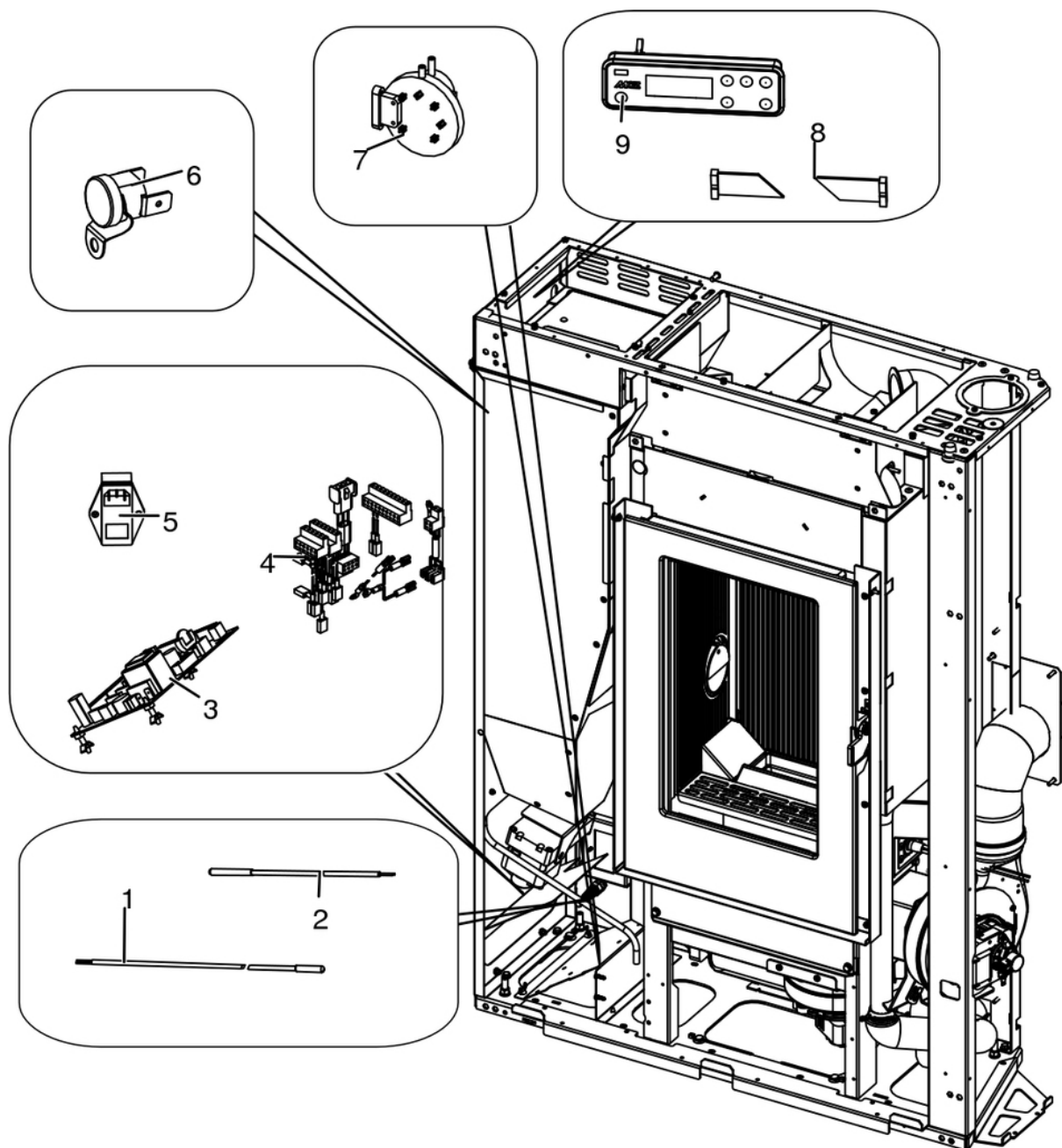

N°	Codice/Code	Descrizioni / Description / Beschreibung / Description / Description
1	4160386	Sonda temperatura ambiente/acqua / Room/Water temperature sensor / Raum- Wassertemperaturfühler / Sonde température ambiance/eau / Sonda temperatura ambiente/agua
2	41451703600	Sonda fumi con flangia con morsettiera L.980 / Smoke sensor with flange with terminal board L.980 / Rauchsonde mit Flansche mit Klemmenbrett L.980 / Sonde fumées avec bride avec serre-câble L.980 / Sonda humos con brida con borne L.980
3	41451400600C	Scheda madre con software precaricato / Motherboard with loaded software / Hauptplatine mit eingegebenem Software / Carte mère avec software préchargé / Tarjeta madre con software precargado
3	41451400600	Scheda madre vergine, senza software / Motherboard with no software / Hauptplatine ohne Software / Carte mère vierge, sans software / Tarjeta madre virgen, sin software
4	41451702800	Cablaggio elettrico / Electrical wiring / Elektrische Verkabelung / Câblage électrique / Cableado eléctrico
5	4160193	Pulsante accensione / On/Off button / Zündungstaste / Touche d'allumage / Botón encendido

6	412007004	Clickson 110°C / Clickson 110°C / Clickson 110°C / Clickson 110°C / Clickson 110°C
7	41451003700	Pressostato / Pressure switch / Druckschalter / Pressostat / Presostato
8	41451201900	Cavo Flat L 1,4 M / Flat cable L 1,4 M / Flat Kable L 1,4 M / Câble Flat L 1,4 M / Cable Flat L 1,4 M
9	41451701500	Pannello comandi / Control panel / Bedienblende / Tableau de commandes / Panel de mandos

RAAM COMFORT AIR 8 S1

Gruppo accensione / Ignition group / Entzündung Gruppe / Groupe d'allumage / Grupo ignición

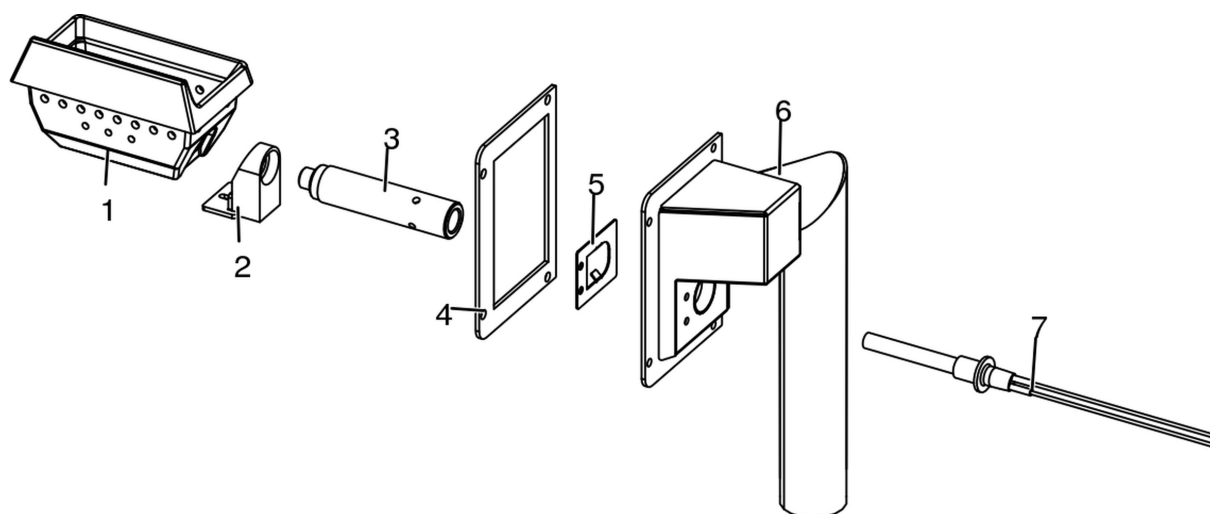

N°	Codice/Code	Descrizioni / Description / Beschreibung / Description / Descripción
1	4130170030100	Braciere ghisa / Cast iron brazier / Brennschale aus Guß / Brasero en fonte / Brasero de arrabio
2	41411741740V	Blocchetto / Little stop / Kleiner Stopper / Petit stop / Tope pequeno
3	41201705400	Condotto candelella / Sparkplug conduit / Zündkerzenkanal / Conduit bougie / Conducto bujía
4	41801702000	Guarnizione scatola / Box gasket / Gehäuse Dichtung / Joint de boite / Burlete caja
5	41401711131	Staffa a molla / Spring bracket / Federhalterung / Support à ressort / Soporte de resorte
6	41411741440V	Scatola aspirazione / Air inlet box / Lufteingangs Schachtel / Coffret entrée d'air / Caja entrada aire
7	41451308101	Candelella 315 Watt / Sparkplug 315 Watt / Zündkerze 315 Watt / Bougie 315 Watt / Bujía 315 Watt
7	41451308150	Kit 25 candelette 315 Watt / 25 Sparkplugs 315 Watt kit / Bausatz 25 Zündkerzen 315 Watt / Kit 25 Bougies 315 Watt / Kit 25 Bujías 315 Watt

RAAM COMFORT AIR 8 S1

Gruppo aria comburente / Combustion air group / Verbrennungsluft Gruppe / Groupe air comburant / Grupo aire comburente

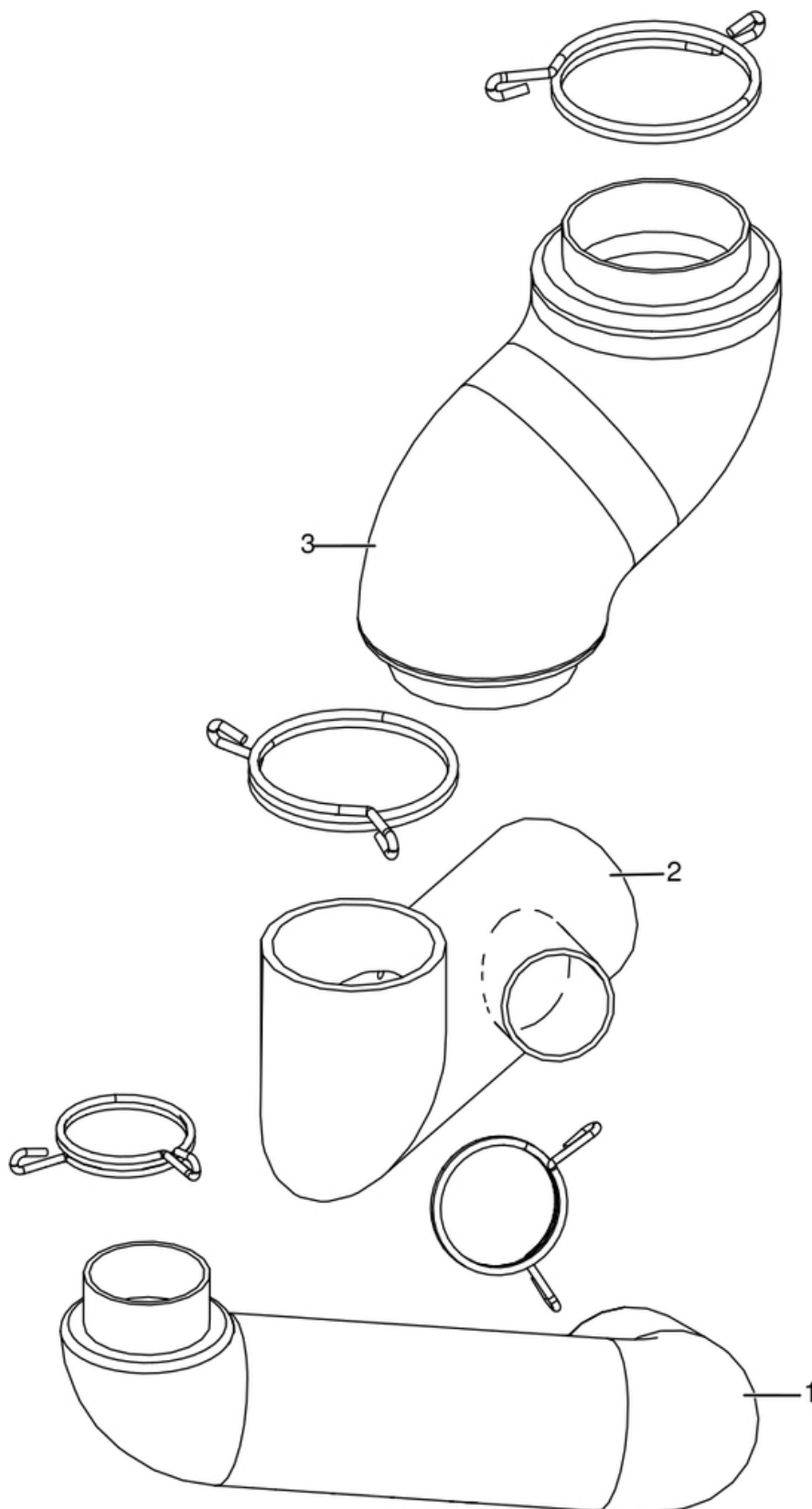

N°	Codice/Code	Descrizioni / Description / Beschreibung / Description / Descripción
1	41801601900	Tubo aspirazione pulizia vetro / Inlet pipe for cleaning glass air / Glassreinigungs Lufteingangsrohr / Tuyau entrée pour l'aire de nettoyage du vitre / Tubo entrada por l'aire de limpieza vidrio
2	41601704060	Tubo aspirazione / Aspiration pipe / Saugleitung / Tuyau d'aspiration / Tubo de aspiracion
3	41801601700	Tubo aspirazione camera combustione / Combustion chamber aspiration tube / Verbrennungskammer Förderrohr / Tuyay aspiration air chambre de combustion / Tubo aspiración aire cámara de combustión

RAAM COMFORT AIR 8 S1

Gruppo ventilazione / Ventilation group / Lüftungsgruppe / Groupe de ventilation / Grupo de ventilación

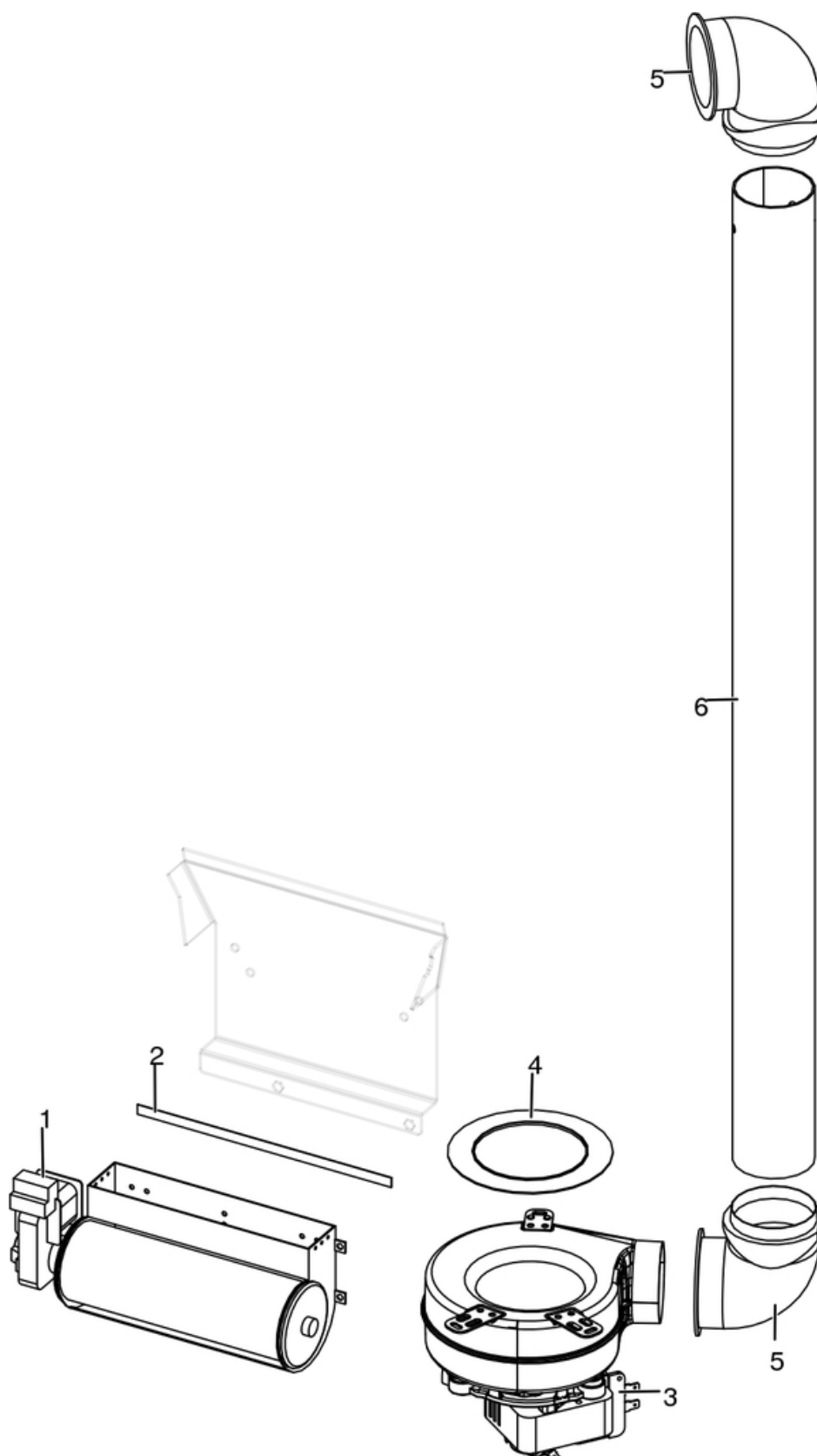

N°	Codice/Code	Descrizioni / Description / Beschreibung / Description / Descripcion
1	41451800900	Ventilatore tangenziale / Warm air fan / Luftgebläse / Ventilateur air / Ventilador aire
2	4120573A	Guarnizione a nastro 8 mm (5 mt.) per porta / Door strip gasket 8 mm (5 m) / Türbanddichtung 8 mm (5 m) / Joint ruban 8 mm (5 m) pour porte / Guarnición de cinta para puerta 8 mm (5 m)
2	4120573B	Guarnizione a nastro 8 mm (50 mt.) per porta / Door strip gasket 8 mm (50 m) / Türbanddichtung 8 mm (50 m) / Joint ruban 8 mm (50 m) pour porte / Guarnición de cinta para puerta 8 mm (50 m)
3	41451503300	Ventilatore centrifugo / Air fun / Lufgebläse / Vantilateur air / Ventilador aire
4	41801601600	Guarnizione ventilatore / Fan gasket / Dichtung des Gebläses / Joint du ventilateur / Junta ventilador
5	41601003600	Tubo 90° / Pipe 90° / Rohr 90° / Tuyau 90° / Tubo 90°
6	41601703160	Tubo aria Ø 60 lungo zincato / Long zinc-coated air pipe Ø 60 / Lang verzinkter Luftrohr Ø 60 / Tuyau air galvanisé long Ø 60 / Tubo aire cincado largo Ø 60

RAAM COMFORT AIR 8 S1

Gruppo fumi / Smoke group / Rauchgruppe / Groupe fumées / Grupo de humos

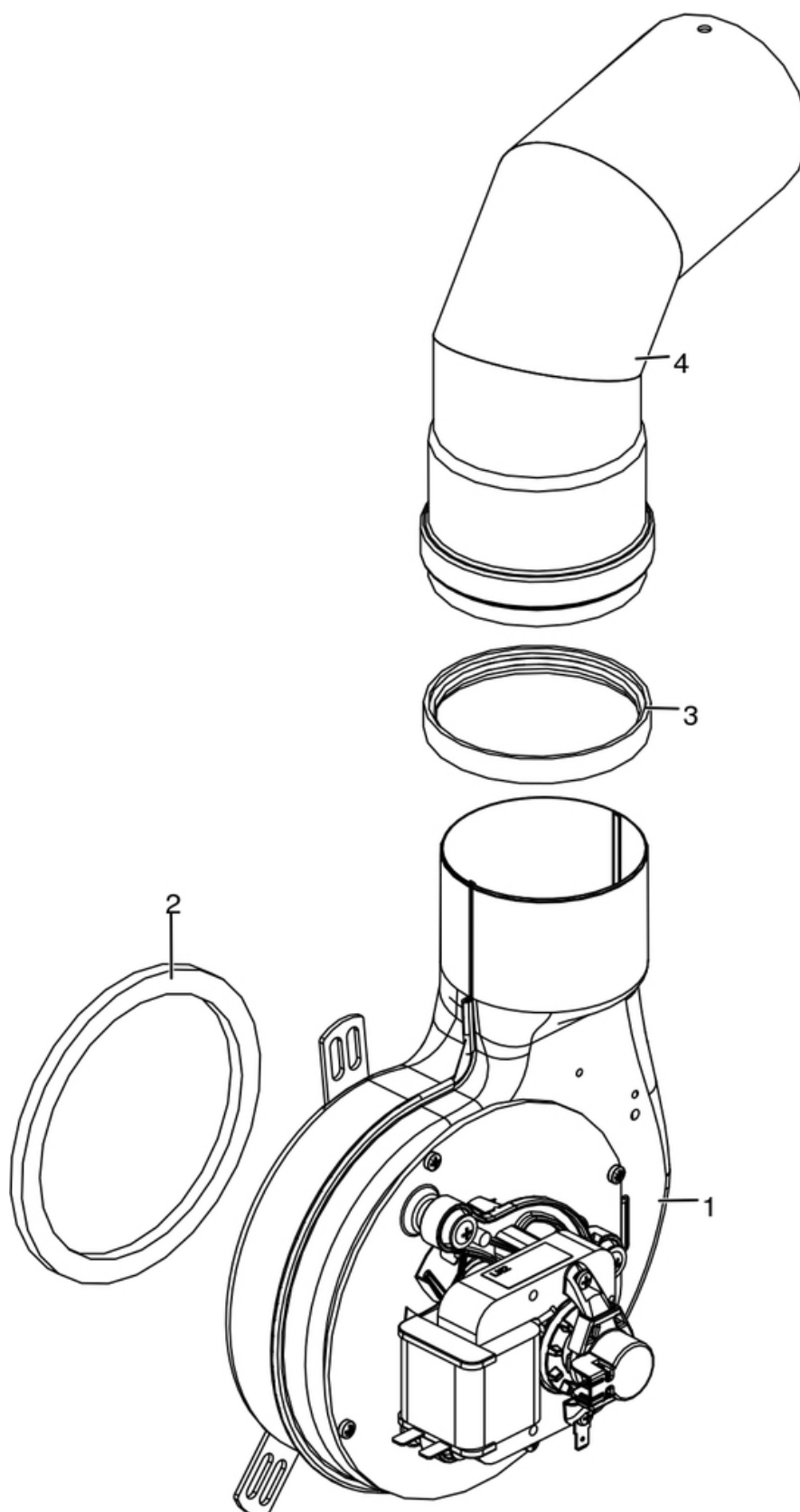

N°	Codice/Code	Descrizioni / Description / Beschreibung / Description / Descripcion
1	41451406501	Ventilatore fumi / Smoke exhausted fan / Rauchgasgebläse / Ventilateur fumées / Ventilador humos
1	41451209300	Encoder per ventilatore fumi marchi LN2/SIT / Encoder for LN2/SIT smoke fan / Encoder für LN2/SIT Rauchgasgebläse / Encoder pour ventilateur des fumées marques LN2/SIT / Encoder para ventilador humos marcas LN2/SIT
1	41452009200	Encoder ventilatore / Fan encoder / Lüfter Encoder / Encodeur de ventilateur / Codificador de ventilador
2	41801002600	Guarnizione adesiva voluta fumi / Adhesive gasket smoke volute / Haftendichtung Rauchvolute / Joint adhesive volute fumées / Junta adhesiva voluta humos
2	41801599850	Kit 50 guarnizioni / Kit 50 gaskets / Bausatz 50 Dichtungen / Kit 50 joints / Kit 50 juntas
3	40120969	Guarnizione silicone (5pz) / Silicone Gasket (5pc.) / Silikondichtung (5 St.) / Joint en silicone / Junta en silicona
4	40160467	Curva 90° Ø 8 Nera / Bend 90° Ø 8 Black / Verlauf 90° Ø 8 Schwarz / Coude 90° Ø 8 Noir / Curva 90° Ø 8 Negra