

DOC COMFORT AIR

Componenti Struttura Esterna / External structure components / Bauteile Aussenkorpus / Composants structure externe / Componentes estructura externa

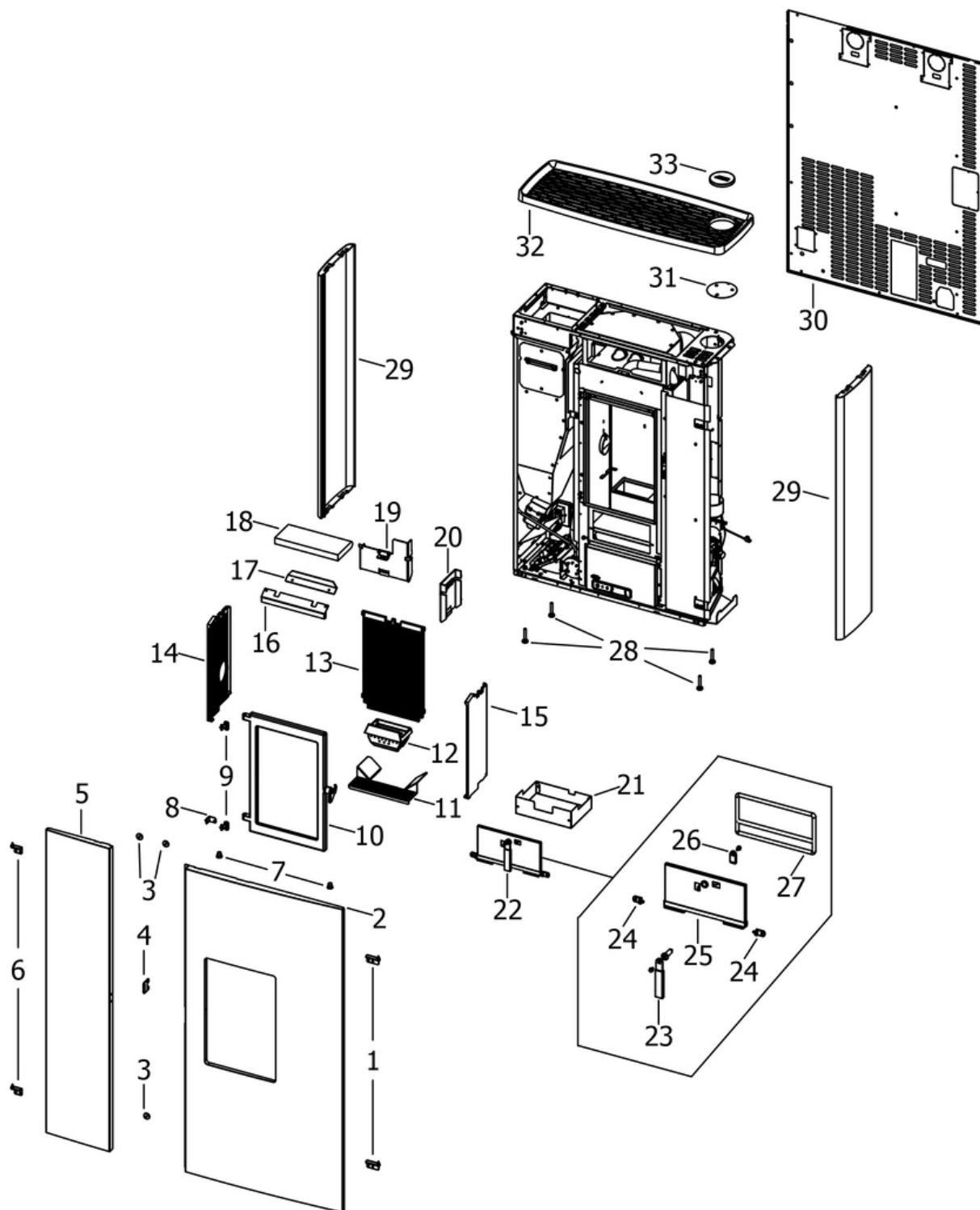

N°	Codice/Code	Descrizioni / Description / Beschreibung / Description / Description
1	41411750240V	Cerniere porta frontale (2 pz) / Hinges frontal door (2 pcs) / Scharniere vordere Tür (2 Stk) / Charnières porte frontale (2 pcs) / Bisagra puerta frontal (2 pz)
2	41411749540P	Porta frontale completa / Complete frontal door / Komplette Fronttür / Porte frontale complète / Puerta frontale completa
3	41801657900	Magneti (pz.2) / Magnet (pcs.2) / Magnet (stk. 2) / Aimant (pcs.2) / Imán (pz.2)

3	41801657900	Magneti (pz.2) / Magnet (pcs.2) / Magnet (stk. 2) / Aimant (pcs.2) / Imán (pz.2)
4	41411744460	Maniglia porta esterna / External door handle / Außentür Griff / Poignée porte extérieur / Tirador puerta exterior
5	41411748850	Porta caricamento pellet completa / Pellet loading door / Tür Pelleteinfüllung / Porte de chargement des pellets / Puerta de carga pellet
6	41411749440V	Cerniere porta caricamento (2 pz) / Hinges loading door (2 pcs) / Scharniere Pelleteinfüllung Tür (2 Stk) / Charnières porte chargement (2 pcs) / Bisagra puerta de carga (2 pz)
7	41801002300	Paracolpi in silicone Ø 8/5 (2pz) / Silicone bumpers Ø 8/5 (2pcs) / Schlagschutzgummi Ø 8/5 (2 Stck) / Pièces silicone antichoc Ø 8/5 (2pcs) / Anti-golpes en silicona Ø 8/5 (2pzs)
8	41411742730V	Blocco porta focolare / Stop for Fireplace door / Stopper für Feuerstelle Tür / Stop pour porte foyer / Tope por puerta hogar
9	41201504460	Cerniera porta (2 pz.) / Door hinge (2 pc.) / Tür Scharnier (2 Stk.) / Charnière porte (2 pc.) / Bisagra puerta (2)
10	437017119	Porta focolare / Fireplace door / Feuerstelle Tür / Porte foyer / Puerta hogar
11	41411742230V	Griglia focolare / Fire box grille / Feuerstellenrost / Grille foyer / Rejilla hogar
12	4130170030100	Braciere ghisa / Cast iron brazier / Brennschale aus Guß / Brasero en fonte / Brasero de arrabio
13	41301700700V	Schiena in ghisa / Cast iron back / Rückwand aus Guß / Fond en fonte / Parte trasera de arrabio
14	41301700600V	Fianco sinistro in ghisa / Left cast iron side / Linke Seite aus Guß / Coté gauche en fonte / Placa lateral izquierda de arrabio
14	41411613530V	Deflettore pellet / Pellet deflector / Pellet Leitblech / Deflecteur pellet / Deflector pellet
15	41301700500V	Fianco destro in ghisa / Right cast iron side / Rechte Seite aus Guß / Coté droit en fonte / Placa lateral derecha de arrabio
16	4141174234100	Deflettore pulizia vetro / Deflector for glass cleaning / Leitblech für Glassreinigung / Deflécteur pour nettoyage du verre / Deflector por limpieza vidrio
17	41331702030	Protezione focolare inox / Inox fire protection / Feuerschutz aus Edelstahl / Protection foyer inox / Protección hogar inox
18	41151702000	Deflettore vermiculite / Vermiculite deflector / Leitblech aus Vermiculite / Défecteur en vermiculite / Deflector en vermiculite
19	41411740131	Tappo post. pulizia struttura / Rear cap for structure cleaning / Hinterer Stöpsel für Korpus Reinigung / Bouchon postérieur pour nettoyage structure / Tapon posterior por limpieza estructura
20	41411740231	Tappo lat. pulizia struttura / Lateral cap for structure cleaning / Seitlicher Stöpsel für Korpus Reinigung / Bouchon lateral pour nettoyage structure / Tapon lateral por limpieza estructura
21	41401713930	Cassetto cenere / Ash drawer / Aschenkasten / Tiroir à cendres / Cajón ceniza
22	437017126	Porta cenere / Ash drawer door / Tür des Aschenkastens / Porte tiroir à cendres / Puerta cajón ceniza
23	41411621600	Maniglia con impugnatura porta cenere / Handle / Griff / Poignée / Tirador
24	41411623740V	Cerniera acciaio porta cenere / Ash compartment door steel hinge / Aschenklappe Stahlscharnier / Charnier en acier porte compartiment cendre / Bisagra en acero puerta compartimento cenizas
24	41411623740V	Cerniera acciaio porta cenere / Ash compartment door steel hinge / Aschenklappe Stahlscharnier / Charnier en acier porte compartiment cendre / Bisagra en acero puerta compartimento cenizas
25	41411742440V	Porta cenere / Ash drawer door / Tür des Aschenkastens / Porte tiroir à cendres / Puerta cajón ceniza
26	41201608400	Serratura porta cassetto cenere / Door lock for ash drawer / Türschloss für Aschenkasten / Serrure de porte du tiroir à cendres / Cerradura puerta cajón ceniza
27	412007003A	Cordino fibroceramico Ø 14 mm (5 mt.) / Ceramic fibre cord Ø 14 mm (5 m.) / Keramikfaserschnur Ø 14 mm (5 m) / Cordon en fibre céramique Ø 14 mm (5 m) / Junta a cuerda de fibra cerámica Ø 14 mm (5 m)
27	412007003B	Cordino fibroceramico Ø 14 mm (50 mt.) / Ceramic fibre cord Ø 14 mm (50 m.) / Keramikfaserschnur Ø 14 mm (50 m) / Cordon en fibre céramique Ø 14 mm (50 m) / Junta a cuerda de fibra cerámica Ø 14 mm (50 m)
27	412007003C	Kit sostituzione cordino (cordino+silicone) Ø 14 mm / Cord replacement kit (cord + silicon) Ø14 mm / Schnuraustauschsatz (Schnur +Silikon) Ø 14 mm / Kit remplacement cordon (cordon+silicon) Ø 14 / Kit sustitución junta a cuerda (junta a cuerda+silicón) Ø 14 mm
28	41200906660	Piedini di appoggio (4 pz.) / Support feet (4 pcs.) / Einstellfüße (4 Stck.) / Vérins d'appui (4 p.es) / Pies de apoyo (4 piezas)
29	41411750340P	Fianco destro/sinistro / Right/left side / Rechte/Linke Seite / Coté droit/gauche / Lateral DCHO/IZQDO
29	41411750340P	Fianco destro/sinistro / Right/left side / Rechte/Linke Seite / Coté droit/gauche / Lateral DCHO/IZQDO
30	41401716030	Schiena esterna posteriore / External rear back / Hintere Rückwand / Dossieret postérieur extérieur / Parte trasera
31	41401715910	Supporto tappo ghisa / Cast iron top support / Stöpselhalterung aus Guß / Support du bouchon en fonte / Supporte tapa en arrabio
32	6917015	Top Black metal_303 / Top Black metal_303 / Top Black metal_303 / Top Black metal_303 / Top Black metal_303
32	6917016	Top Aluminium metal_315 / Top Aluminium metal_315 / Top Aluminium metal_315 / Top Aluminium metal_315 / Top Aluminium metal_315
33	6917015	Top Black metal_303 / Top Black metal_303 / Top Black metal_303 / Top Black metal_303 / Top Black metal_303

33	6917016	Top Aluminuim metal_315 / Top Aluminuim metal_315 / Top Aluminuim metal_315 / Top Aluminuim metal_315 / Top Aluminuim metal_315
----	---------	---

DOC COMFORT AIR

Porta fuoco / Fire door / Feuertür / Porte foyer / Puerta hogar

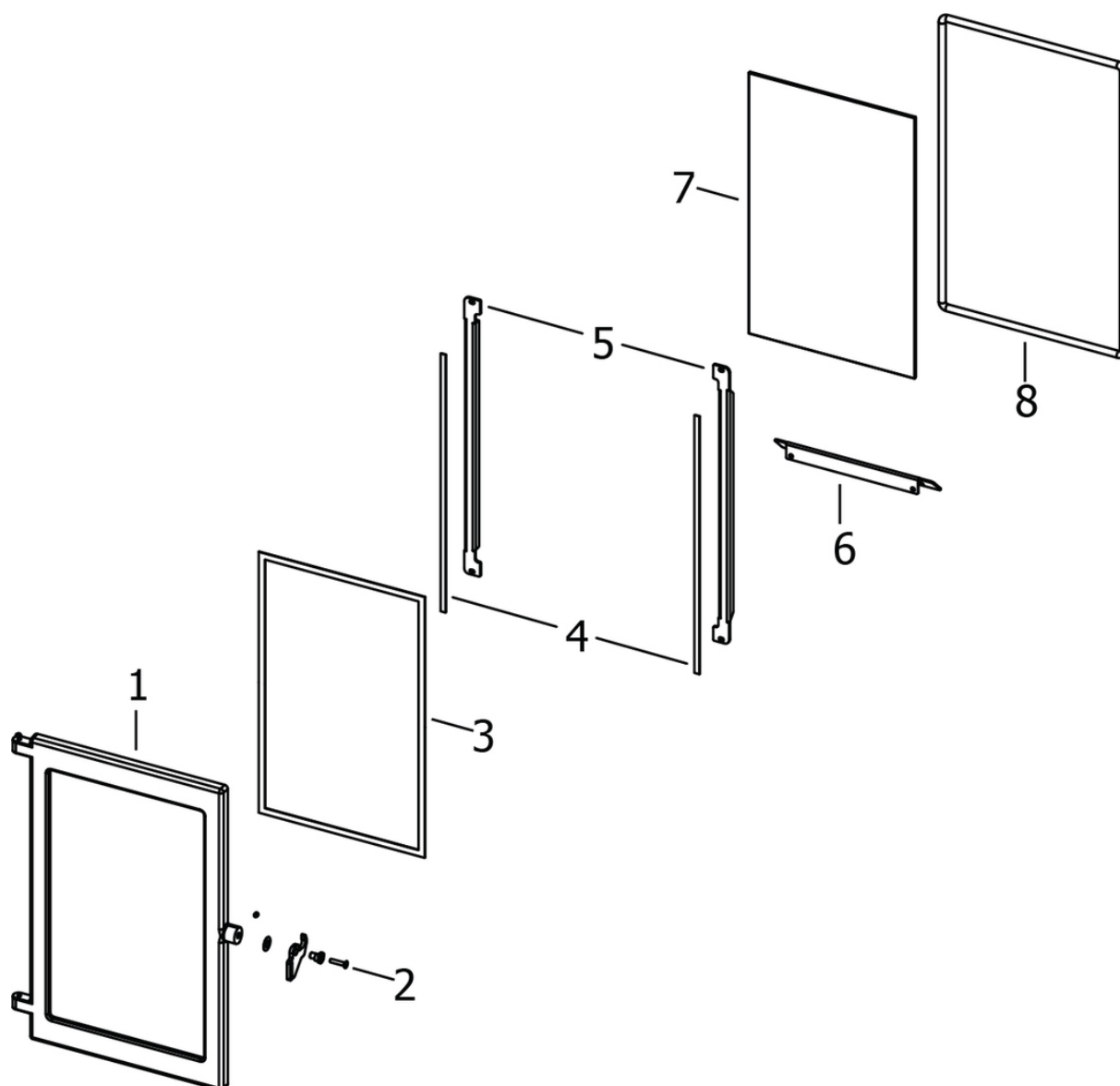

N°	Codice/Code	Descrizioni / Description / Beschreibung / Description / Descripción
1	41301700400V	Porta focolare ghisa / Cast iron fire door / Feuertür aus Guß / Porte foyer en fonte / Puerta hogar de arrabio
2	41411742161	Maniglia porta focolare / Fire door handle / Feuertür Griff / Poignée porte foyer / Tirador puerta fuego
3	41801603300A	Guarnizione Ø5 5mt / Gasket Ø5 5mt / Dichtung Ø5 5mt / Joint Ø5 5mt / Junta Ø5 5mt
3	41801603300B	Guarnizione Ø5 50mt / Gasket Ø5 50mt / Dichtung Ø5 50mt / Joint Ø5 50mt / Junta Ø5 50mt
3	41801603300C	Guarnizione Ø5 5mt + silicone / Gasket Ø5 5mt + silic / Dichtung Ø5 5mt + Silikon / Joint Ø5 5mt + silic / Junta Ø5 5mt
4	4120573A	Guarnizione a nastro 8 mm (5 mt.) per porta / Door strip gasket 8 mm (5 m) / Türbanddichtung 8 mm (5 m) / Joint ruban 8 mm (5 m) pour porte / Guarnición de cinta para puerta 8 mm (5 m)
4	4120573B	Guarnizione a nastro 8 mm (50 mt.) per porta / Door strip gasket 8 mm (50 m) / Türbanddichtung 8 mm (50 m) / Joint ruban 8 mm (50 m) pour porte / Guarnición de cinta para puerta 8 mm (50 m)
5	4160170440000	Profilo fermavetro / Fastening bracket profile / Haltebügel für Scheibebefestigung Profil / Profil patte de fixation / Perfil fermacristal
6	4141174203100	Scivolo cenere / Ash ramp / Aschenrutsche / Glissèrie cendre / Tobogán ceniza
7	41701701800	Vetroceramico porta tecnica / Technical door glass / Glas für technische Tür / Vitrocéramique porte technique / Cristal cerámico puerta técnica
8	4120104A	Cordino fibroceramico Ø 12 mm (5 mt.) / Ceramic fibre cord Ø 12 mm (5 m.) / Keramikfaserschnur Ø 12 mm (5 m) /

		Cordon en fibre céramique Ø 12 mm (5 m) / Junta a cuerda de fibra cerámica Ø 12 mm (5 m)
8	4120104B	Cordino fibroceramico Ø 12 mm (50 mt.) / Ceramic fibre cord Ø 12 mm (50 m.) / Keramikfaserschnur Ø 12 mm (50 m) / Cordon en fibre céramique Ø 12 mm (50 m) / Junta a cuerda de fibra cerámica Ø 10 mm (52 m)
8	41201041	Kit sostituzione cordino (cordino+silicone) Ø 12 mm / Cord replacement kit (cord + silicon) Ø 12 mm / Schnuraustauschsatz (Schnur+Silikon) Ø 12 mm / Kit remplacement cordon (cordon + silicone) Ø 12 mm / Kit sustitución junta a cuerda (junta a cuerda+silicón) Ø 12 mm

DOC COMFORT AIR

Componenti interni meccanici ed elettronici / Electronic and mechanic internal parts / Interne mechanische und elektronische Bauteile / Composants internes mécaniques et électroniques / Componentes internos electrónicos y mecánicos

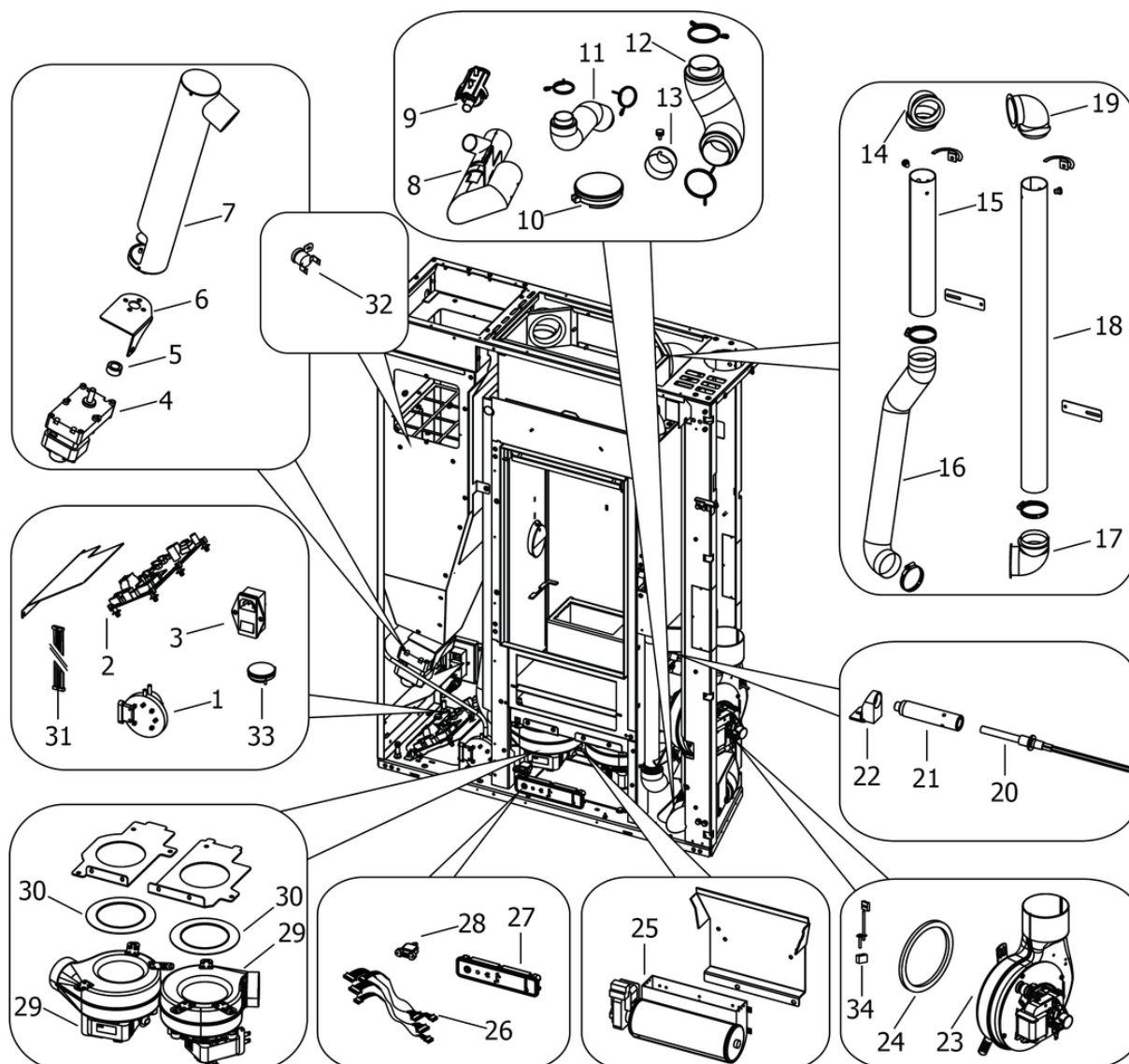

N°	Codice/Code	Descrizioni / Description / Beschreibung / Description / Descripción
1	41451003700	Pressostato / Pressure switch / Druckschalter / Pressostat / Presostato
2	41451602602	Scheda elettronica plus / Electronix mother board plus / Elektronische Platine Plus / Carte mère électronique plus / Tarjeta madre electronica plus
3	4160193	Pulsante accensione / On/Off button / Zündungstaste / Touche d'allumage / Botón encendido
4	41451503100	Motoriduttore 2rpm / Gear motor 2rpm / Getriebemotor 2rpm / Motoréducteur 2rpm / Motorreductor 2rpm
5	4120398	Connettore motoriduttore-coclea / Reduction motor-feed screw connector / Verbindung Getriebemotor-Schnecke / Connecteur motoréducteur-vis sans fin / Conector motorreductor-cóclea
6	41401623830	base coclea pellet / Feed screw base for pellet / Untergestell der Förderschnecke für Pellet / Base de la vis sans fin granulé / Base de la còclea pellets
7	41411741151	Alimentazione completa / Complete power / Komplette Anspeisung / Alimentation complète / Alimentacion completa
7	41801600400	Guarnizione gruppo caricamento / Gasket / Dichtung / Joint / Junta
7	41801702600	Disaccoppiatore misc. Marrone / Brown disengaging device / Braun Verängungsrohr / Tuyau de découplage maron / Tubo de desvío marron
8	41601703360	Tubo aspirazione zincato / Zinc-coated air inlet pipe / Verzinkter Lufteingangsrohr / Tuyau entrée d'air galvanisé / Tubo entrada aire cincando

9	41601301850	Componente rilevamento portata aria / Air flow measure component / Bauteil für Messung der Luftmenge / Composent pour la mesuration de la quantité d'air / Componente por la medida de l'aire
10	41451303400	Trasduttore di pressione / Pressure transducer / Active-Wandler / Transducteur de pression / Transductor de pression
10	4120631A	Tubicino silicónico - 5m / Silicon tube - 5m / Silikonrohr - 5m / Petit tuyau en silicone - 5m / Tubo silicónico - 5m
11	41801601900	Tubo aspirazione pulizia vetro / Inlet pipe for cleaning glass air / Glassreinigungs Lufteingangsrohr / Tuyau entrée pour l'aire de nettoyage du verre / Tubo entrada por l'aire de limpieza vidrio
12	41801601700	Tubo aspirazione camera combustione / Combustion chamber aspiration tube / Verbrennungskammer Förderrohr / Tuyau aspiration air chambre de combustion / Tubo aspiración aire cámara de combustión
13	41401036100	Filtro antipolvere / Anti-dust filter / Staubschutzfilter / Filtre antipoussière / Filtro de protección polvo
14	41601003600	Tubo 90° / Pipe 90° / Rohr 90° / Tuyau 90° / Tubo 90°
15	41601703260	Tubo aria Ø 60 corto zincato / Short zinc-coated air pipe Ø 60 / Kurz verzinkter Luftrohr Ø 60 / Tuyau air galvanisé court Ø 60 / Tubo aire cincado corto Ø 60
16	4009003	Tubo flessibile Ø 60 mm lunghezza 1,5 m / Flex pipe Ø 60 mm length 1,5 m / Schlauch Ø 60 mm Länge 1,5 m / Tuyau flexible Ø 60 mm longueur 1,5 m / Tubo flexible Ø 60 mm lunghezza 1,5 m
16	4009017	Tubo flessibile Ø 60 mm lunghezza 8 m / Flex pipe Ø 60 mm length 8 m / Schlauch Ø 60 mm Länge 8 m / Tuyau flexible Ø 60 mm longueur 8 m / Tubo flexible Ø 60 mm lunghezza 8 m
17	41601003600	Tubo 90° / Pipe 90° / Rohr 90° / Tuyau 90° / Tubo 90°
18	41601703160	Tubo aria Ø 60 lungo zincato / Long zinc-coated air pipe Ø 60 / Lang verzinkter Luftrohr Ø 60 / Tuyau air galvanisé long Ø 60 / Tubo aire cincado largo Ø 60
19	41601003600	Tubo 90° / Pipe 90° / Rohr 90° / Tuyau 90° / Tubo 90°
20	41451308101	Candeletta 315 Watt / Sparkplug 315 Watt / Zündkerze 315 Watt / Bougie 315 Watt / Bujia 315 Watt
20	41451308150	Kit 25 candelette 315 Watt / 25 Sparkplugs 315 Watt kit / Bausatz 25 Zündkerzen 315 Watt / Kit 25 Bougies 315 Watt / Kit 25 Bujias 315 Watt
21	41201705400	Condotto candeletta / Sparkplug conduit / Zündkerzenkanal / Conduit bougie / Conducto bujia
22	41411741740V	Blocchetto / Little stop / Kleiner Stopper / Petit stop / Tope pequeno
23	41451406501	Ventilatore fumi / Smoke exhausted fan / Rauchgasgebläse / Ventilateur fumées / Ventilador humos
23	41801102500	Guarnizione / Gasket / Dichtung / Joint / Junta
23	41451209300	Encoder per ventilatore fumi marchi LN2/SIT / Encoder for LN2/SIT smoke fan / Encoder für LN2/SIT Rauchgasgebläse / Encoder pour ventilateur des fumées marques LN2/SIT / Encoder para ventilador humos marcas LN2/SIT
23	41452009200	Encoder ventilatore / Fan encoder / Lüfter Encoder / Encodeur de ventilateur / Codificador de ventilador
24	41801002600	Guarnizione adesiva voluta fumi / Adhesive gasket smoke volute / Haftendichtung Rauchvolute / Joint adhesive volute fumées / Junta adhesiva voluta humos
24	41801599850	Kit 50 guarnizioni / Kit 50 gaskets / Bausatz 50 Dichtungen / Kit 50 joints / Kit 50 juntas
25	41451702300	Ventilatore tangenziale / Warm air fan / Luftgebläse / Ventilateur air / Ventilador aire
26	41451801600	Cavo flat 20 vie L.600 mm / Flat cable 20 pin L.600 mm / Flat-Kabel 20polig L.600 mm / Cable flat 20 voies L.600 mm / Flat cable 20 vias L.600 mm
27	41451602802	Pannello di emergenza Wireless / Wireless emergency display / Wireless Notfall-Blende / Panneau d'urgence wireless / Panel emergencia wireless
28	41451403200	Cavo USB da pannello L.500 / USB Cable from display L.500 / USB Kabel von Notfalldisplay L.500 / Câble USB de panneau L.500 / Cable USB del panel L.500
29	41451503300	Ventilatore centrifugo / Air fun / Lufgebläse / Vantilateur air / Ventilador aire
29	41451503300	Ventilatore centrifugo / Air fun / Lufgebläse / Vantilateur air / Ventilador aire
30	41801601600	Guarnizione ventilatore / Fan gasket / Dichtung des Gebläses / Joint du ventilateur / Junta ventilador
30	41801601600	Guarnizione ventilatore / Fan gasket / Dichtung des Gebläses / Joint du ventilateur / Junta ventilador
31	41451702400	Cablaggio elettrico / Electrical wiring / Elektrische Verkabelung / Câblage électrique / Cableado eléctrico
32	412007004	Clickson 110°C / Clickson 110°C / Clickson 110°C / Clickson 110°C / Clickson 110°C
33	4020006	Telecomando / Remote control / Fernbedienung / Télécommande / Mando a distancia
33	4017014	Sensore temperatura Wireless / temperature sensor Wireless / Temperaturfühler Wireless / Capteur de Temperatur Wiresless / Sensor de temperatura Wireless
34	41451703600	Sonda fumi con flangia con morsetti L.980 / Smoke sensor with flange with terminal board L.980 / Rauchsonde mit Flansche mit Klemmbrett L.980 / Sonde fumées avec bride avec serre-câble L.980 / Sonda humos con brida con borne L.980