

## ALYSSA AIR 6 M1

Gruppo estetico / Aesthetic group / Aesthetische Gruppe / Groupe esthétique / Grupo estético

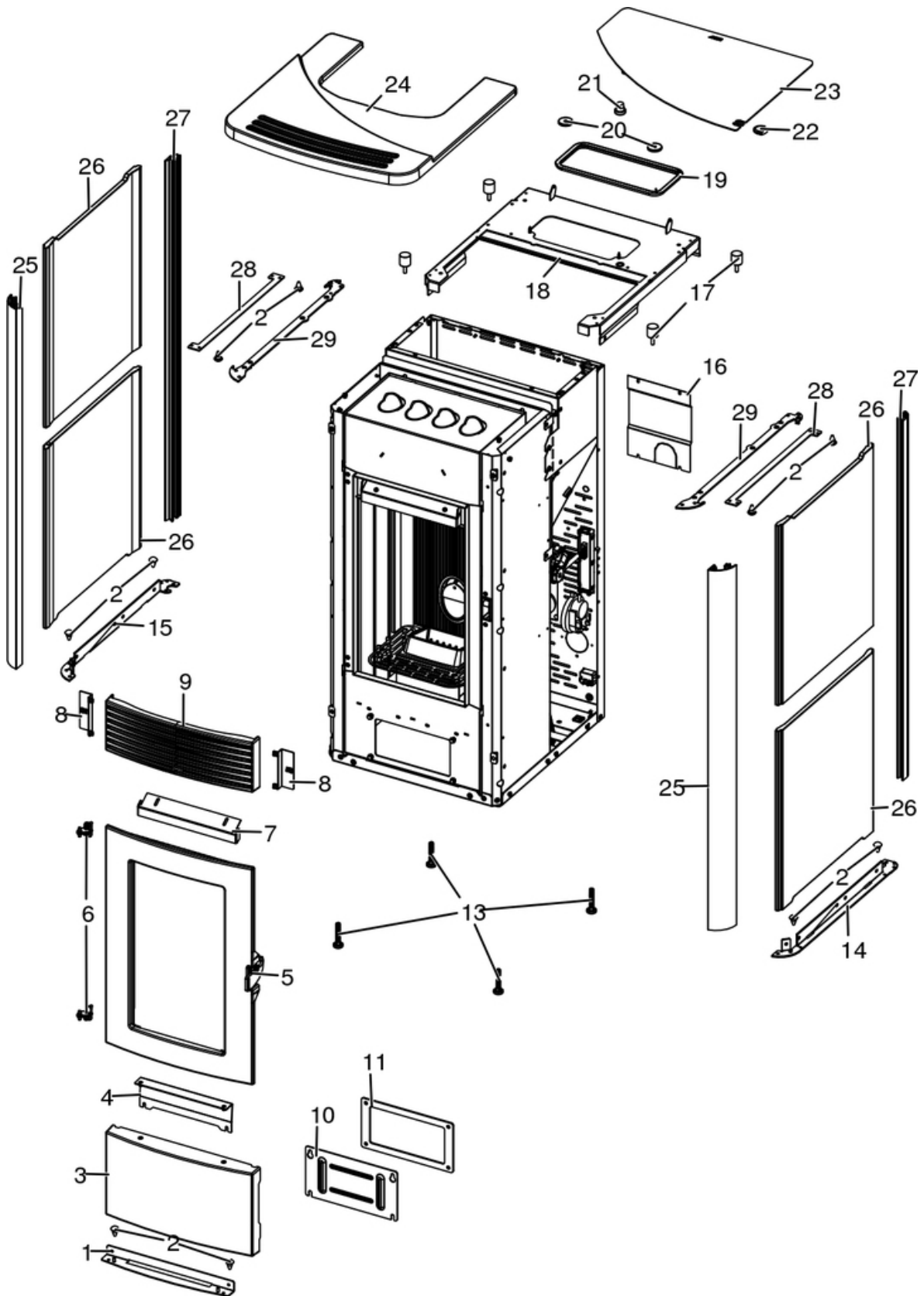

N°	Codice/Code	Descrizioni / Description / Beschreibung / Description / Descripcion
1	41411904440	Staffa inferiore / Lower bracket / Hunterer Halterung / Support inférieur / Soporte inferior
2	41801002300	Paracolpi in silicone Ø 8/5 (2pz) / Silicone bumpers Ø 8/5 (2pcs) / Schlagschutzgummi Ø 8/5 (2 Stck) / Pièces silicone antichoc Ø 8/5 (2pcs) / Anti-golpes en silicona Ø 8/5 (2pzs)
3	4130180160000	Pannello inferiore in ghisa / Cast iron lower panel / Unteres Paneel aus Gusseisen / Panneau inférieur en fonte / Panel inferior en arrabio
4	41401852130	Staffa bloccaggio ghisa / Cast iron blocking bracket / Gusseisen- Haltebügel / Étrier blocage en fonte / Abrazadera bloqueo en arrabio
5	437019043	Porta completa / Complete door / Komplette Tür / Porte complète / Puerta completa
6	41201504460	Cerniera porta (2 pz.) / Door hinge (2 pc.) / Tür Scharnier (2 Stk.) / Charnière porte (2 pc.) / Bisagra puerta (2)
7	41411615430V	Deflettore aria / Air deflector / Luftleitblech / Déflecteur aire / Deflector aire
8	41411904560	Staffa sostegno griglia / Grille support bracket / Stahlrost- Haltebügel / Etrier support de grille / Abrazadera de soporte Rejilla
9	4130180150000	Pannello superiore nero in ghisa / Upper black cast iron panel / Obere schwarze Paneel aus Gusseisen / Panneau supérieur noir en fonte / Panel superior negro de arrabio
10	41401339610	Tappo ispezione vano fumi / Smoke compartment inspection plug / Inspektionsdeckel Rauchabzug / Clapet inspection compartiment fumées / Tapón inspección compartimento humos
11	41800900600	Guarnizione / Gasket / Dichtung / Joint / Junta
11	41801599750	Kit 50 guarnizioni / Kit 50 gaskets / Bausatz 50 Dichtungen / Kit 50 joints / Kit 50 juntas
13	41200906660	Piedini di appoggio (4 pz.) / Support feet (4 pcs.) / Einstellfüße (4 Stck.) / Vérins d'appui (4 p.es) / Pies de apoyo (4 piezas)
14	4141190373000	Supporto dx / RH support / RS Halterung / Supprt droite / Soporte DCHO
15	4141190383000	Supporto sx / LH support / LS Halterung / Support gauche / Soporto IZDO
16	41401612530	Coperchio motoriduttore / Reduction motor cover / Deckel des Getriebemotors / Couvercle motoréducteur / Tapa del motorreductor
17	41201701950	Gommini antivibrante / Vibration damper rubber / Rammschutz Gummi / Caoutchouc antivibratoire / Cauchitos antivibración
18	4141190414000	Supporto top / Cover support / Deckel- Halterung / Supprt du couvercle / Soporte tapadera
19	41801601400	Guarnizione coperchio serbatoio / Pellet hopper cover gasket / Deckel Pelletbehälter Dichtung / Joint couvercle réervoir pellet / Junta tapa depósito pellet
20	41801657900	Magneti (pz.2) / Magnet (pcs.2) / Magnet (stk. 2) / Aimant (pcs.2) / Imán (pz.2)
21	4120180	Gommini paracolpi (4 pz) / Rubber bumpers (4 pcs.) / Schlagschutzgummi (4 Stck) / Pièces caoutchouc antichoc (4 pcs) / Cauchitos anti-golpes (4 pz)
22	41801903700	Maniglia / Handle / Griff / Poignée / Tirador
23	4141190404000	Coperchio nero / Black cover / Schwarze Deckel / Couvercle noir / Tapadera negra
23	41801701400	Logo MCZ / MCZ logo / MCZ logo / MCZ logo / MCZ logo
24	4130180170000	Top nero / Black top / Schwarze Top / Top noir / Top negro
25	4131180275000	Profilo anteriore completo in alluminio / Front aluminium profile / Komplettes vordere Profil aus Aluminium / Profil antérieur complet en aluminium / Perfil anterior completo en aluminio
26	4125180170000	Ceramica laterale Warm grey / Warm grey side ceramic / Seitliche Keramik Warm grey / Céramique latérale Warm grey / Cerámica lateral Warm grey
26	4125180170001	Ceramica laterale Bordeaux / Bordeaux side ceramic / Seitliche Keramik Bordeaux / Céramique latérale Bordeaux / Cerámica lateral Bordeaux
26	4125180170002	Ceramica laterale White / White side ceramic / Seitliche Keramik White / Céramique latérale White / Cerámica lateral White
27	4131180285000	Profilo posteriore completo in alluminio / Rear aluminium profile / Komplettes hintere Profil aus Aluminium / Profil postérieur complet en aluminium / Perfil posterior completo en aluminio
28	4141190201000	Staffa bloccaggio ceramica / Ceramic blocking bracket / Keramik-Haltebügel / Étrier blocage carreaux en céramique / Abrazadera bloqueo cerámicas
29	4141190211000	Piastra superiore / Upper plate / Obere Platte / Plaque supérieure / Placa superior

## ALYSSA AIR 6 M1

Gruppo camera di combustione / Combustion chamber group / Verbrennungskammer Gruppe / Group de chambre de combustion / Grupo cámara de combustión

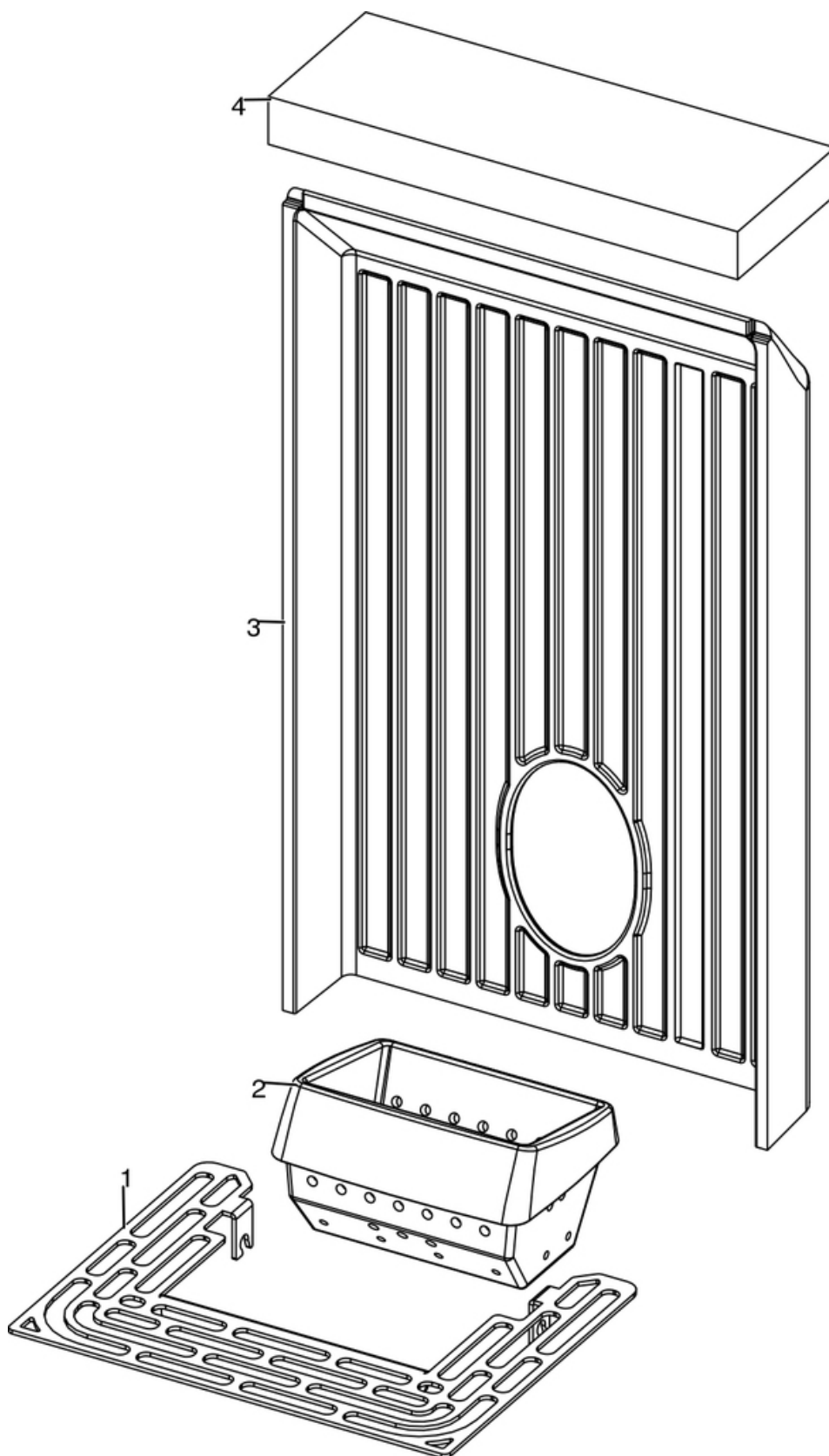

N°	Codice/Code	Descrizioni / Description / Beschreibung / Description / Descripcion
1	41411634830V	Griglia focolare / Fire Box Grille / Feuerstellenrost / Grille Foyer / Rejilla Hogar
2	41301502400V	Braciare ghisa / Cast iron grate / Brennertopf aus Gusseisen / Brasero en fonte / Brasero en arrabio
3	41301502600V	Schiena ghisa / Cast iron back / Rückwand aus Gusseisen / Dossieret en fonte / Parte trasera en arrabio
4	41151600200	Deflettore focolare in vermiculite / Vermiculite deflector / Leitblech aus Vermiculite / Déflecteur en vermiculite / Deflector en vermiculite

## ALYSSA AIR 6 M1

Porta fuoco / Fire door / Feuertür / Porte foyer / Puerta hogar

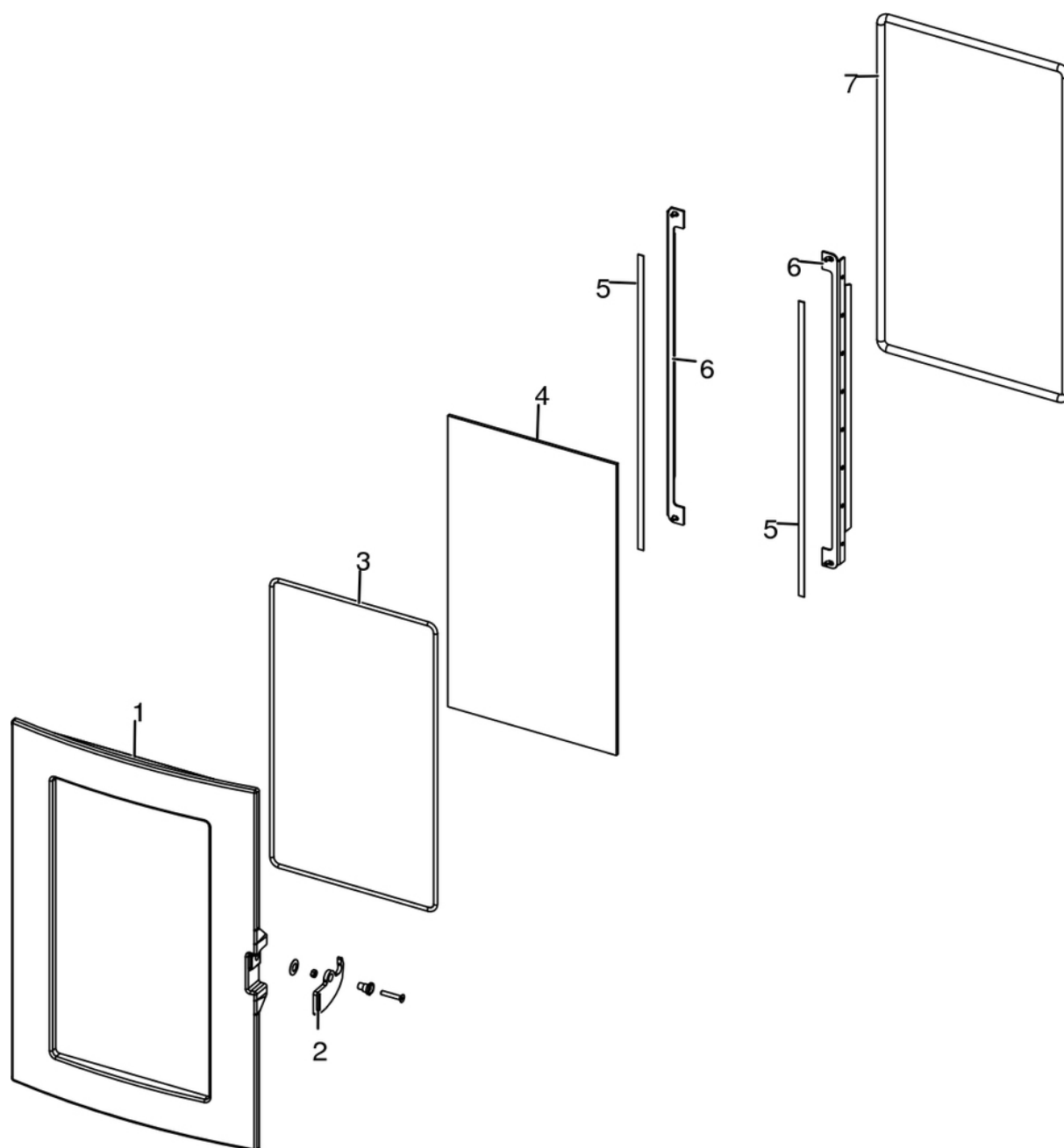

N°	Codice/Code	Descrizioni / Description / Beschreibung / Description / Descripción
1	41301600400V	Porta fuoco in ghisa / Cast iron fire door / Feuertür aus Guß / Porte foyer en fonte / Puerta hogar de arrabio
2	41401424160	Maniglia completa / Complete handle / Kompletter Griff / Poignée complète / Tirador completo
3	41801603300A	Guarnizione Ø5 5mt / Gasket Ø5 5mt / Dichtung Ø5 5mt / Joint Ø5 5mt / Junta Ø5 5mt
3	41801603300B	Guarnizione Ø5 50mt / Gasket Ø5 50mt / Dichtung Ø5 50mt / Joint Ø5 50mt / Junta Ø5 50mt
3	41801603300C	Guarnizione Ø5 5mt + silicone / Gasket Ø5 5mt + silic / Dichtung Ø5 5mt + Silikon / Joint Ø5 5mt + silic / Junta Ø5 5mt
4	41701600300	Vetroceramico porta ghisa / Cast iron door glass / Glaskeramikscheibe Tür aus Gusseise / Vitrocéremique porte en fonte / Cristal cerámico puerta en arrabio
5	4120573A	Guarnizione a nastro 8 mm (5 mt.) per porta / Door strip gasket 8 mm (5 m) / Türbanddichtung 8 mm (5 m) / Joint ruban 8 mm (5 m) pour porte / Guarnición de cinta para puerta 8 mm (5 m)
5	4120573B	Guarnizione a nastro 8 mm (50 mt.) per porta / Door strip gasket 8 mm (50 m) / Türbanddichtung 8 mm (50 m) / Joint ruban 8 mm (50 m) pour porte / Guarnición de cinta para puerta 8 mm (50 m)

<b>6</b>	<b>41411622030V</b>	Profilo fermavetro / Fastening bracket profile / Haltebügel für Scheibebefestigung Profil / Profil patte de fixation / Perfil fermacristal
<b>7</b>	<b>4120104A</b>	Cordino fibroceramico Ø 12 mm (5 mt.) / Ceramic fibre cord Ø 12 mm (5 m.) / Keramikfaserschnur Ø 12 mm (5 m) / Cordon en fibre céramique Ø 12 mm (5 m) / Junta a cuerda de fibra cerámica Ø 12 mm (5 m)
<b>7</b>	<b>4120104B</b>	Cordino fibroceramico Ø 12 mm (50 mt.) / Ceramic fibre cord Ø 12 mm (50 m.) / Keramikfaserschnur Ø 12 mm (50 m) / Cordon en fibre céramique Ø 12 mm (50 m) / Junta a cuerda de fibra cerámica Ø 10 mm (52 m)
<b>7</b>	<b>41201041</b>	Kit sostituzione cordino (cordino+silicone) Ø 12 mm / Cord replacement kit (cord + silicon) Ø 12 mm / Schnuraustauschsatz (Schnur+Silikon) Ø 12 mm / Kit remplacement cordon (cordon + silicone) Ø 12 mm / Kit sustitución junta a cuerda (junta a cuerda+silicón) Ø 12 mm

## ALYSSA AIR 6 M1

Gruppo accensione / Ignition group / Entzündung Gruppe / Groupe d'allumage / Grupo ignición

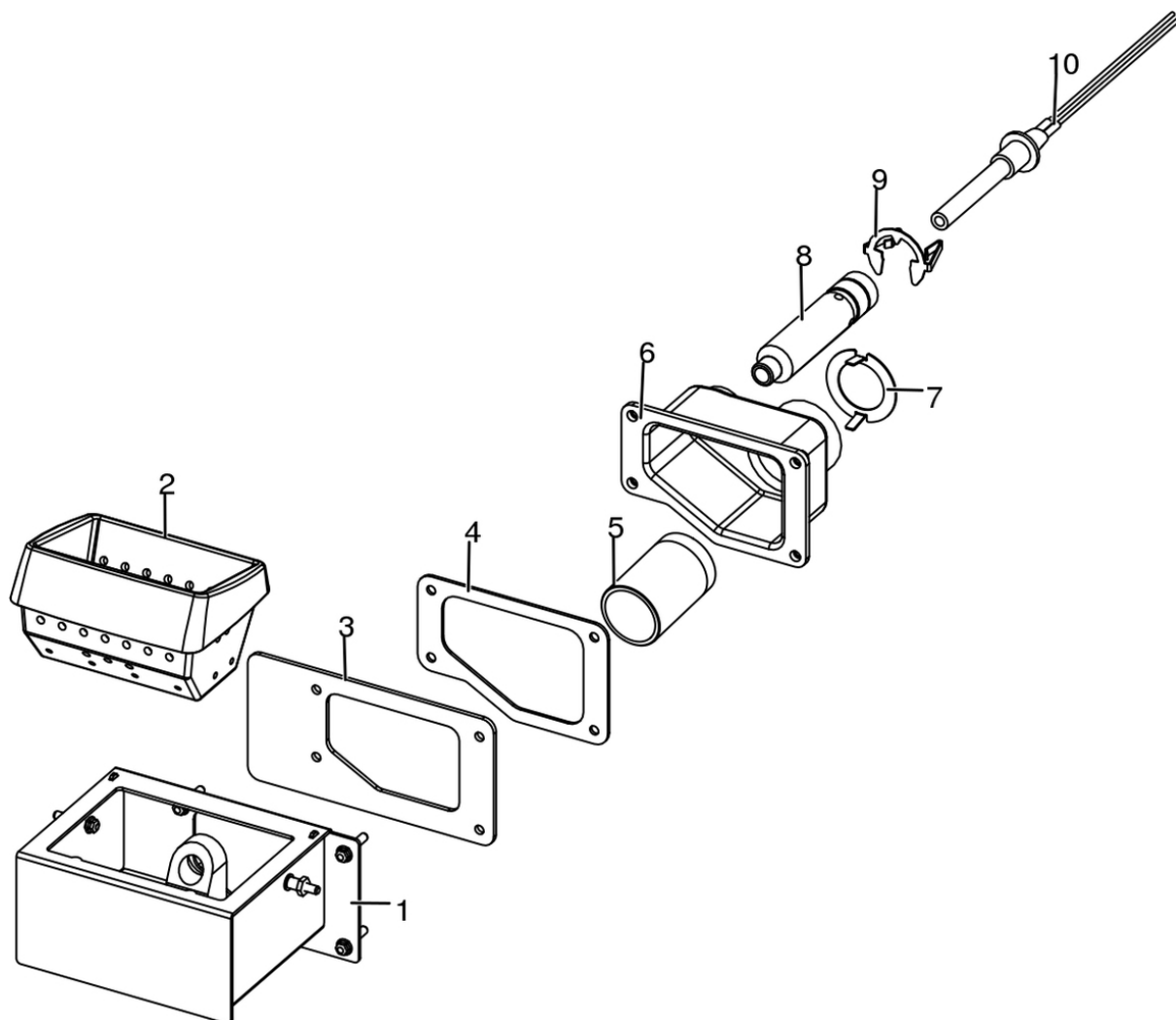

N°	Codice/Code	Descrizioni / Description / Beschreibung / Description / Descripción
1	41411613140V	Tasca braciere / Combustion pot container / Brenntopfkasten / Récipient brasero / Contenidor brasero
2	41301502400V	Braciere ghisa / Cast iron grate / Brennertopf aus Gusseisen / Brasero en fonte / Brasero en arrabio
3	41801601500	Guarnizione tasca braciere / Combustion pot container gasket / Brenntopfkasten Dichtung / Joint récipient brasero / Junta contenidor brasero
4	41801602300	Guarniziono codolo / Gasket / Dicktung / Joint / Junta
5	41501701599	Manicotto potenziamento accensione / Combustion air extension pipe / Zusatzrohr für Nachrüstung / Tuyau amélioration allumage / Tubo impulso de encendido
6	41311803500	Codolo / Tool chuck / Einspannschaft / Outil d'emmanchement / Mango
7	41401629410	Regolatore ingresso aria comburente / Combustion air intake adjuster / Regler Eingang Verbrennungsluft / Régulateur arrivée air comburant / Regulador entrada aire comburente
8	41601601000	Condotto candeletta / Sparkplug Conduit / Zündkerzenkanal / Conduit Bougie / Conducto Bujía
9	41201601500	Anello arresto candeletta / Sparkplug stop / Zündkerzestopper / Butée bougie / Tope bujía
10	41451308101	Candeletta 315 Watt / Sparkplug 315 Watt / Zündkerze 315 Watt / Bougie 315 Watt / Bujía 315 Watt
10	41451308150	Kit 25 candelette 315 Watt / 25 Sparkplugs 315 Watt kit / Bausatz 25 Zündkerzen 315 Watt / Kit 25 Bougies 315 Watt / Kit 25 Bujías 315 Watt

## ALYSSA AIR 6 M1

Gruppo caricamento pellet / Pellet feed group / Pellet Fördergruppe / Groupe chargement du pellet / Grupo de carga pellet

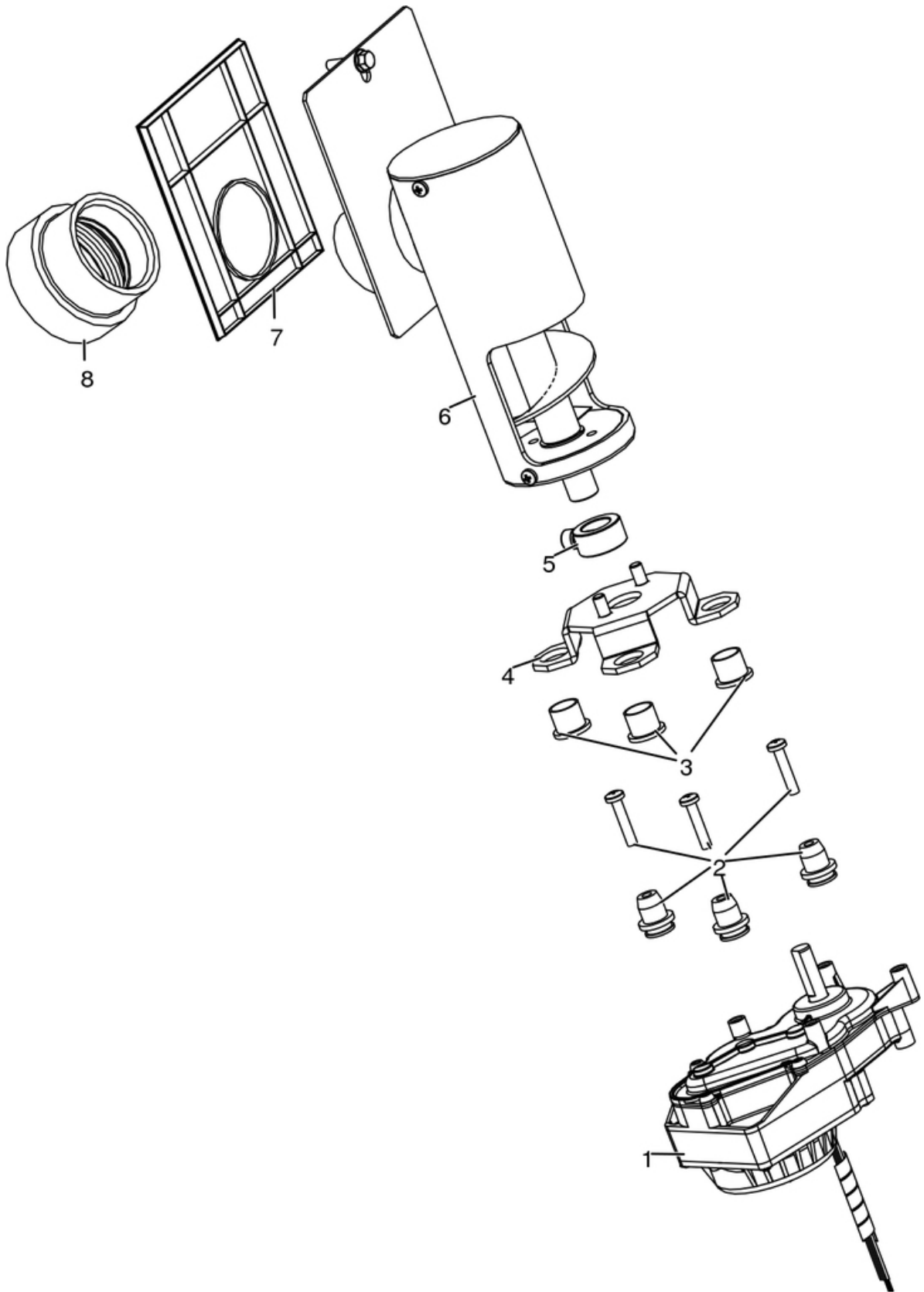



N°	Codice/Code	Descrizioni / Description / Beschreibung / Description / Descripción
1	41451702200	Motoriduttore brushless / Brushless reduction motor / Brushless Getriebemotor / Motoréducteur brushless / Motorreductor brushless
2	41801703700	Gommini antivibrante / Vibration damper rubber / Rammschutz Gummi / Caoutchouc antivibratoire / Cauchitos antivibración
3	41201800700	Boccola (3 pz) / Bushing (3 pcs) / Buchse (3 Stk) / Douille (3 pcs) / Abrazadera (3 pzs)
4	41411779331	Supporto coclea "Ragno" / Pellet feed screw bracket "spider" / "Spinne" Schenke Gestell / Support vis sans fin "Araignée" / Soporte coclea "Araña"
5	4120398	Connettore motoriduttore-coclea / Reduction motor-feed screw connector / Verbindung Getriebemotor-Schnecke / Connecteur motoréducteur-vis sans fin / Conector motorreductor-cóclea
6	41411800151	Gruppo alimentazione completo / Complete feed screw / Komplette Förderschnecke / Vis sans fin complète / Coclea de carga completa
7	41801600400	Guarnizione gruppo caricamento / Gasket / Dichtung / Joint / Junta
8	41801702600	Disaccoppiatore mesc. Marrone / Brown disengaging device / Braun Verängungsrohr / Tuyau de découplage maron / Tubo de desvío marron

## ALYSSA AIR 6 M1

Gruppo aria comburente / Combustion air group / Verbrennungsluft Gruppe / Groupe air comburant / Grupo aire comburente

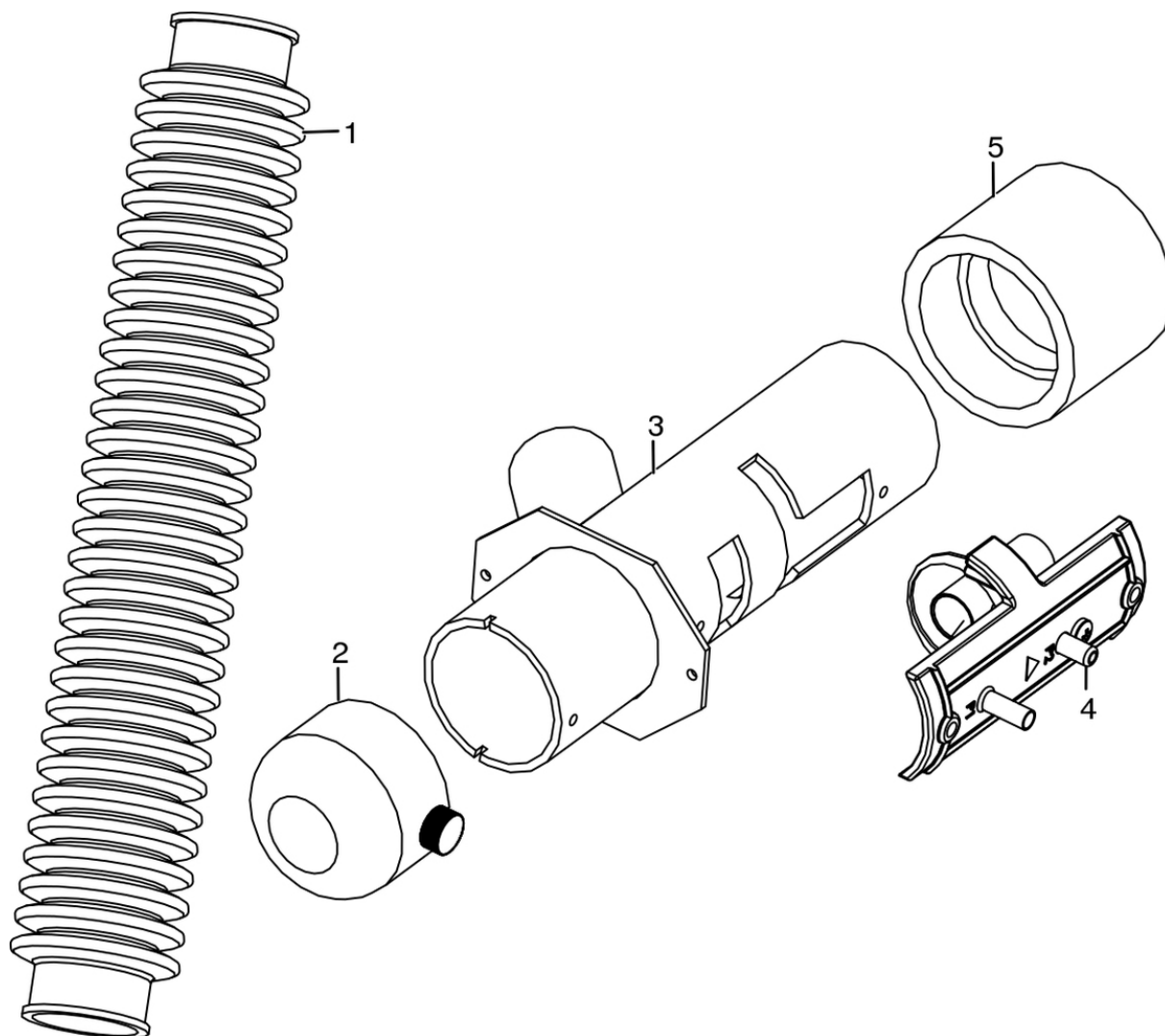

N°	Codice/Code	Descrizioni / Description / Beschreibung / Description / Descripción
1	41801601900	Tubo aspirazione pulizia vetro / Inlet pipe for cleaning glass air / Glassreinigungslufteingangsrohr / Tuyau entrée pour l'aire de nettoyage du vitre / Tubo entrada por l'aire de limpieza vidrio
2	41401036100	Filtro antipolvere / Anti-dust filter / Staubschutzfilter / Filtre antipoussière / Filtro de protección polvo
3	41601604461	Tubo aspirazione / Air inlet pipe / Lufteingangsrohr / Tuyau entrée d'air / Tubo entrada aire
4	41601301850	Componente rilevamento portata aria / Air flow measure component / Bauteil für Messung der Luftmenge / Composent pour la mesuration de la quantité d'air / Componente por la medida de l'aire
5	41201707900	Manicotto in gomma / Rubber pipe / Gummi Zusatzrohr / Tuyau gomme / Tubo en goma

## ALYSSA AIR 6 M1

Gruppo elettrico ed elettronico / Electrical and electronic group / Elektrische und elektronische Gruppe / Groupe électrique et électronique / Grupo eléctrico y electrónico

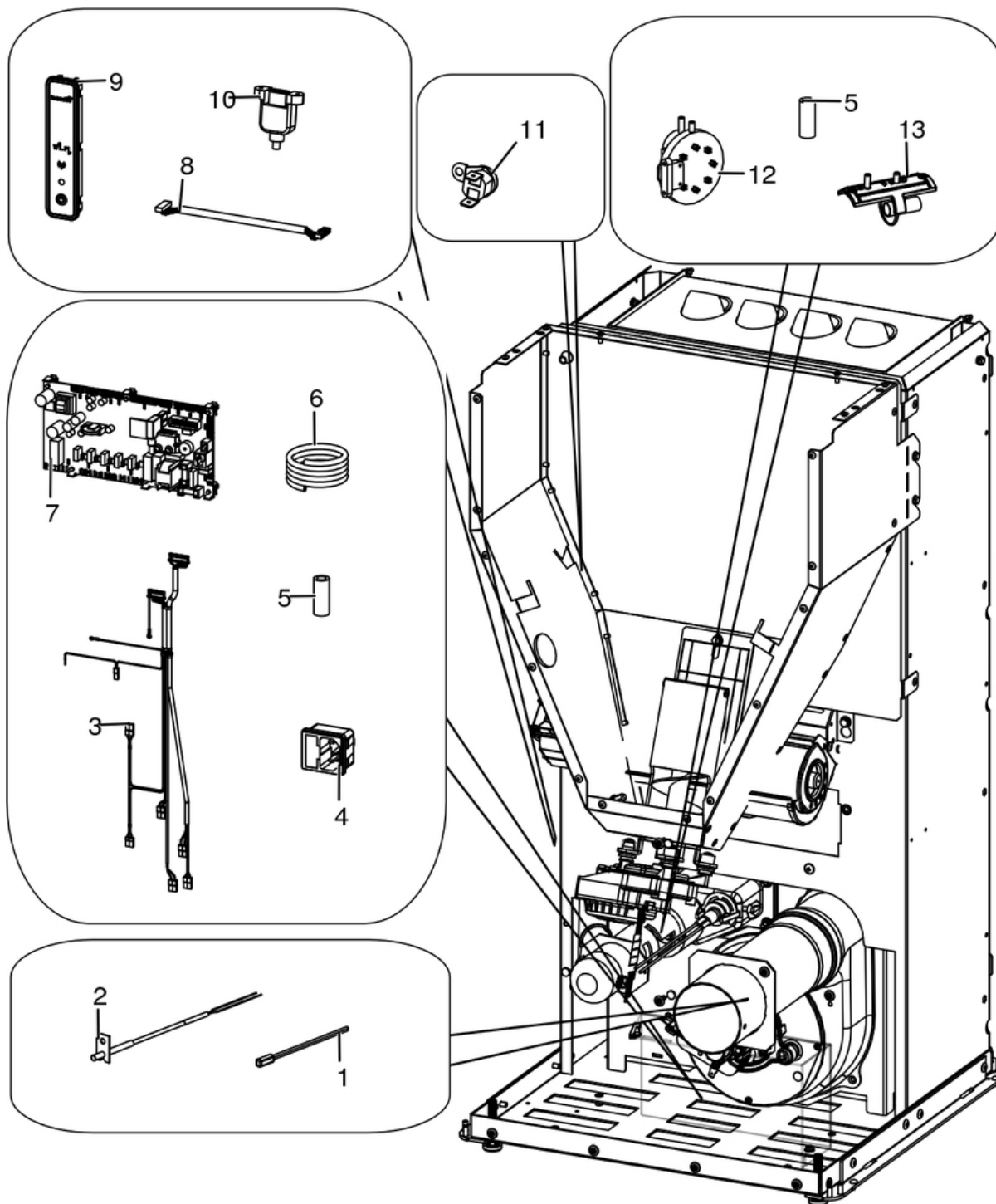

N°	Codice/Code	Descrizioni / Description / Beschreibung / Description / Description
1	4160386	Sonda temperatura ambiente/acqua / Room/Water temperature sensor / Raum- Wassertemperaturfühler / Sonde température ambiance/eau / Sonda temperatura ambiente/agua
2	41451703600	Sonda fumi con flangia con morsetteria L.980 / Smoke sensor with flange with terminal board L.980 / Rauchsonde mit Flansche mit Klemmenbrett L.980 / Sonde fumées avec bride avec serre-câble L.980 / Sonda humos con brida con borne L.980
3	41451904700	Cablaggio elettrico Maestro / Maestro electrical wiring / Elektrische Verkabelung Maestro / Câblage électrique Maestro / Cableado eléctrico Maestro

<b>3</b>	<b>4145200500</b>	Cavo motoriduttore / Reduction motor cable / Kabel Getriebemotor / Câble motoréducteur / Cable motorreductor
<b>4</b>	<b>41451104100</b>	Presca con fusibile / Socket with fuse / Steckdose mit Sicherung / Prise avec fusible / Toma con fusible
<b>5</b>	<b>4120631A</b>	Tubicino silicónico - 5m / Silicon tube - 5m / Silikonrohr - 5m / Petit tuyau en silicone - 5m / Tubo silicónico - 5m
<b>6</b>	<b>41801902500A</b>	Spirale Rilsan (5 spire) / Rilsan spiral (5 coils) / Spirale Rilsan (5 Windungen) / Spirale Rilsan (5 spires) / Espiral Rilsan (5 espire)
<b>6</b>	<b>41801902500</b>	Spirale Rilsan (30 m.) / Rilsan spiral (30 m.) / Spirale Rilsan (30 M.) / Spirale Rilsan (30 m.) / Espiral Rilsan (30 m.)
<b>7</b>	<b>41451904300</b>	Scheda madre / Motherboard / Hauptplatine / Carte mère / Tarjeta madre
<b>7</b>	<b>41451904300A</b>	Sensirion / Sensirion / Sensirion / Sensirion / Sensirion
<b>8</b>	<b>41451801600</b>	Cavo flat 20 vie L.600 mm / Flat cable 20 pin L.600 mm / Flat-Kabel 20polig L.600 mm / Cable flat 20 voies L.600 mm / Flat cable 20 vias L.600 mm
<b>9</b>	<b>41451602802</b>	Pannello di emergenza Wireless / Wireless emergency display / Wireless Notfall-Blende / Panneau d'urgence wireless / Panel emergencia wireless
<b>10</b>	<b>41451403200</b>	Cavo USB da pannello L.500 / USB Cable from display L.500 / USB Kabel von Notfalldisplay L.500 / Câble USB de panneau L.500 / Cable USB del panel L.500
<b>11</b>	<b>412007004</b>	Clickson 110°C / Clickson 110°C / Clickson 110°C / Clickson 110°C / Clickson 110°C
<b>12</b>	<b>41451003700</b>	Pressostato / Pressure switch / Druckschalter / Pressostat / Presostato
<b>13</b>	<b>41601301850</b>	Componente rilevamento portata aria / Air flow measure component / Bauteil für Messung der Luftmenge / Composent pour la mesuration de la quantité d'air / Componente por la medida de l'aire

## ALYSSA AIR 6 M1

Gruppo fumi / Smoke group / Rauchgruppe / Groupe fumées / Grupo de humos

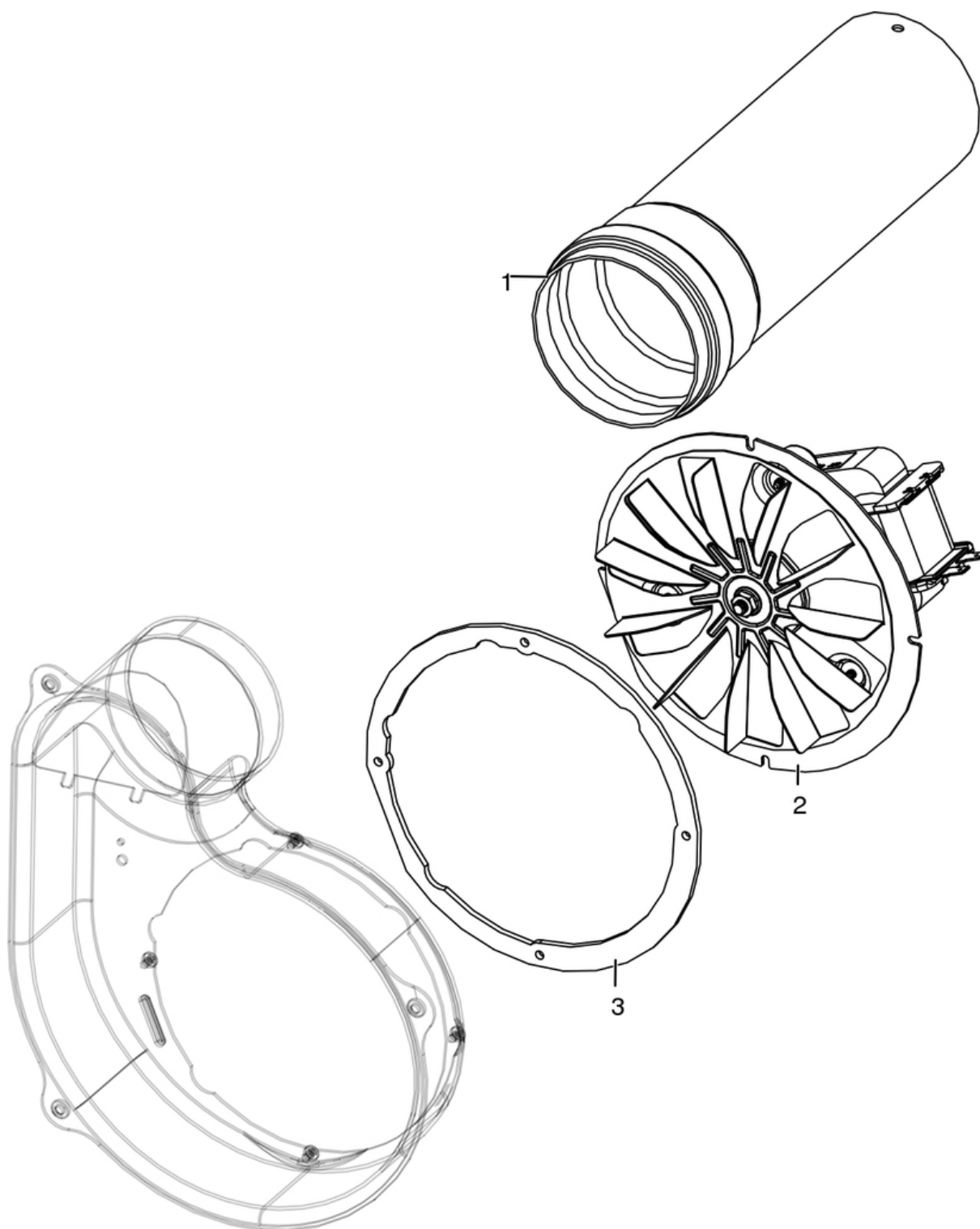

N°	Codice/Code	Descrizioni / Description / Beschreibung / Description / Descripcion
1	41601603000	Tubo Ø8 L.25 con guarnizione / Pipe Ø8 L.25 with gasket / Rohr Ø8 L.14 mit Dichtung / Tuyau Ø8 L.25 avec joint / Tubo Ø8 L.25 con guarnición
2	41451503200	Ventilatore fumi stagno / Air-tight smoke exhausted fan / Luftdichtes Rauchgasgebläse / Ventilateur fumées étanche / Ventilador humos hermético
2	41451703000	Encoder per ventilatore fumi marchio EBM / Encoder for EMB smoke fan / Encoder für EBM Rauchgasgebläse /

		Encoder pour ventilateur des fumées marque EBM / Encoder para ventilador humos marca EBM
<b>2</b>	<b>41451209300</b>	Encoder per ventilatore fumi marchi LN2/SIT / Encoder for LN2/SIT smoke fan / Encoder für LN2/SIT Rauchgasgebläse / Encoder pour ventilateur des fumées marques LN2/SIT / Encoder para ventilador humos marcas LN2/SIT
<b>2</b>	<b>41452009200</b>	Encoder ventilatore / Fan encoder / Lüfter Encoder / Encodeur de ventilateur / Codificador de ventilador
<b>3</b>	<b>41801600800</b>	Guarnizione ventilatore fumi / Smoke exhaust fan gasket / Dichtung Rauchabsauggebläse / Joint Ventilateur aspiration fumées / Junta ventilador aspiración humos

## ALYSSA AIR 6 M1

Gruppo ventilazione / Ventilation group / Lüftungsgruppe / Groupe de ventilation / Grupo de ventilación

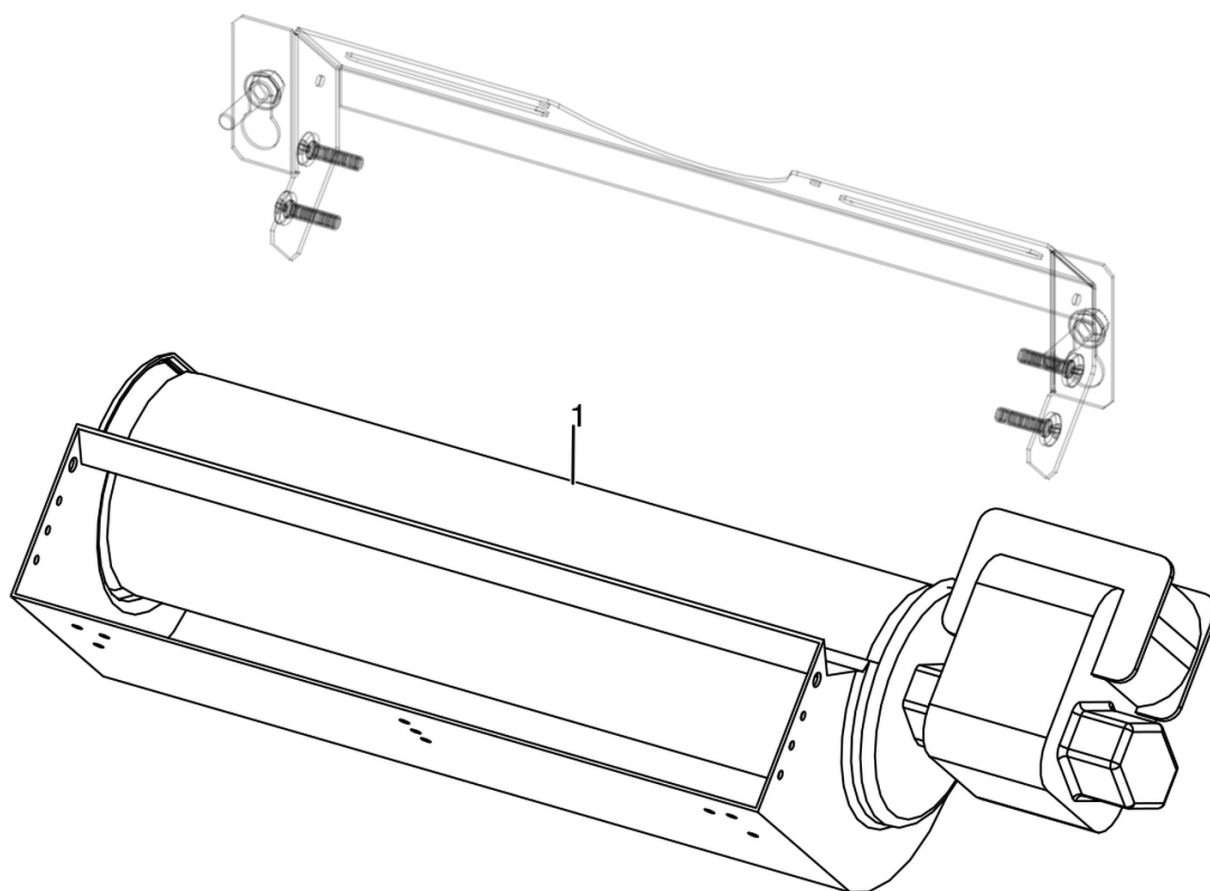

N°	Codice/Code	Descrizioni / Description / Beschreibung / Description / Descripción
1	41451600800	Ventilatore aria / Air fan / Luftgebläse / Ventilateur air / Ventilador aire