

## LOOP AIR 8 M1

Gruppo estetico / Aesthetic group / Aesthetische Gruppe / Groupe esthétique / Grupo estético

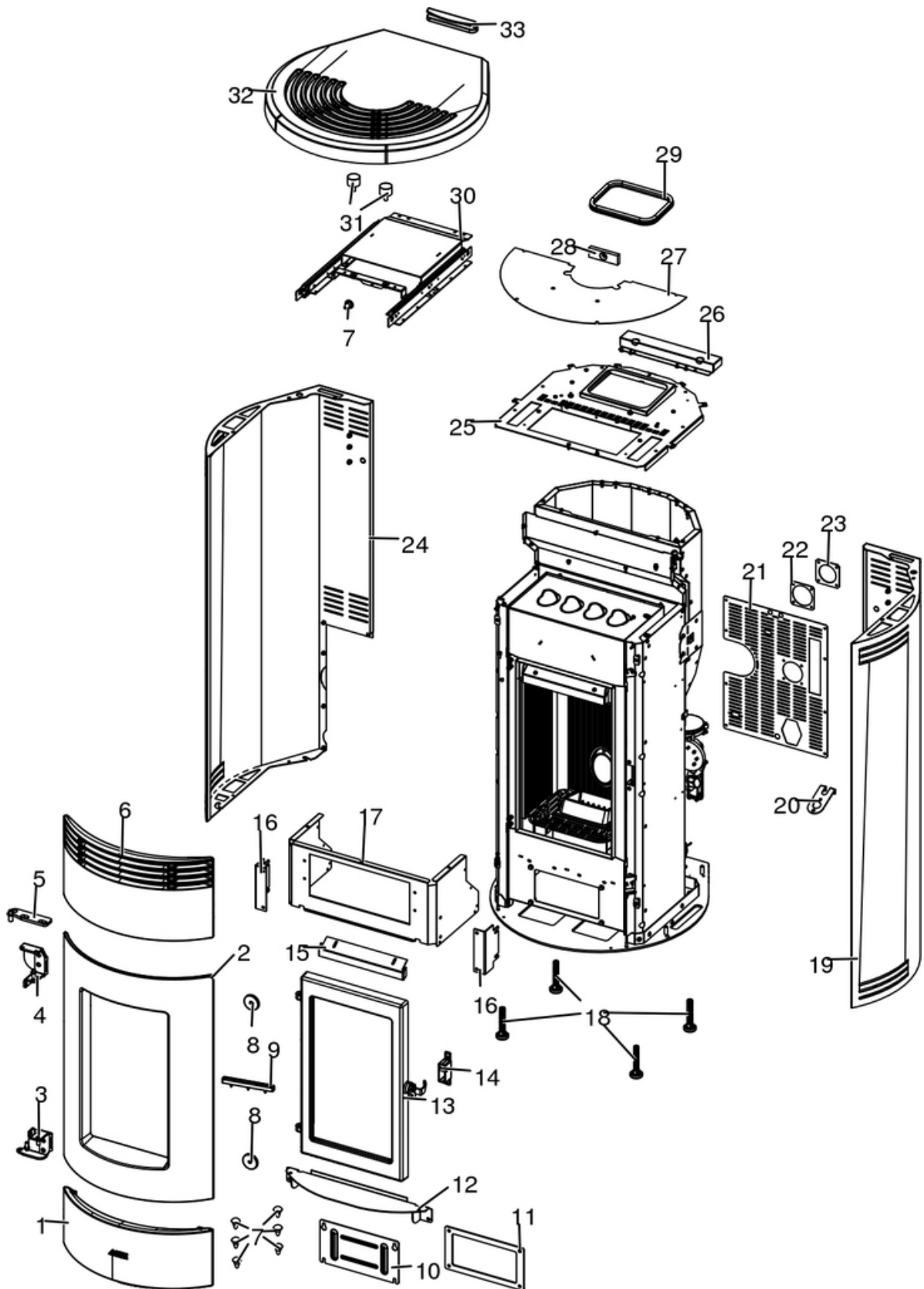

N°	Codice/Code	Descrizioni / Description / Beschreibung / Description / Descripcion
1	4130170330100	Frontalino in ghisa / Cast iron filler / Stopfung aus Gusseisen / Plaque en fonte / Tapa de arrabio
2	4130170350100	Porta estetica ghisa / Cast iron aesthetic door / Ästhetische Tür aus Gusseisen / Porte esthétique en fonte / Puerta estética de arrabio
3	4141181164000	Cerniera inferiore nera / Lower hinge-Black / Unteres Scharnier-Schwarz / Charnière inférieure noire / Bisagra inferior negra
4	4141181174000	Cerniera superiore nera / Upper hinge-Black / Oberes Scharnier-Schwarz / Charnière supérieure noire / Bisagra superior negra
5	4141181184100	Perno superiore nero / Upper pivot-Black / Oberes Angelpunkt-Schwarz / Pivot superieur noir / Perno superior negro
6	4130170340000	Frontale ghisa nera / Cast iron front panel black / Vordere Platte aus Guss schwarz / Plaque frontale en fonte noir / Panel frontal de arrabio negro
7	41801002300	Paracolpi in silicone Ø 8/5 (2pz) / Silicone bumpers Ø 8/5 (2pcs) / Schlagschutzgummi Ø 8/5 (2 Stck) / Pièces silicone antichoc Ø 8/5 (2pcs) / Anti-golpes en silicona Ø 8/5 (2pzs)
8	41801657900	Magneti (pz.2) / Magnet (pcs.2) / Magnet (stk. 2) / Aimant (pcs.2) / Imán (pz.2)
9	41801500900	Paracolpi porta esterna / External door bumper / Außentürstoßfänger / Butoir porte extérieure / Paragolpes puerta exterior
10	41401339610	Tappo ispezione vano fumi / Smoke compartment inspection plug / Inspektionsdeckel Rauchabzug / Clapet inspection compartiment fumées / Tapón inspección compartimento humos
11	41800900600	Guarnizione / Gasket / Dichtung / Joint / Junta
11	41801599750	Kit 50 guarnizioni / Kit 50 gaskets / Bausatz 50 Dichtungen / Kit 50 joints / Kit 50 juntas
12	4141181223000	Staffa inferiore nera / Lower door bracket-Black / Hunterer Bügel-Schwarz / Étrier inférieur noir / Abrazadera inferior negra
13	437017082	Porta fuoco in ghisa / Cast iron fireplace door / Feuerür aus Gusseisen / Porte foyer en fonte / Puerta hogar de arrabio
14	41411599950	Kit serratura ammortizzato / Pressur relief kit / Bausatz Überdruckablauf Brennkammer / Kit decompression chambre comcusion / Kit decompression camara combustion
15	41411615430V	Deflettore aria / Air deflector / Luftleitblech / Déflecteur aire / Deflector aire
16	4141181233000	Supporto dx/sx frontale nero / Front L./R. support-Black / Vordere R./L. Gestell-Schwarz / Support D./G. panneau antérieur noir / Soporte DCHO/IZDO panel frontal negro
17	4141180433000	Convogliatore / Air duct / Förder / Convoyeur / Conductor
18	41200906660	Piedini di appoggio (4 pz.) / Support feet (4 pcs.) / Einstellfüße (4 Stck.) / Vérins d'appui (4 p.es) / Pies de apoyo (4 piezas)
19	4141181414100	Fianco dx black / R. side black / Seite R. Schwarz / Côté D. noir / Lateral DCHO negro
19	4141181414101	Fianco dx silver / R. side silver / Seite R. Silver / Côté D. Silver / Lateral DCHO Silver
20	41401800930	Supporto posteriore fianchi / Back sides support / Hintere Seiten Stütze / Support posterieur côtés / Soporte posterior lados
21	4141181241100	Pannello posteriore / Back panel / Hintere Paneel / Panneau posterieur / Panel posterior
22	41401228110	Supporto guarnizione / Seal support / Dichtungsunterstützung / Support de joint / Sello de soporte
23	41801200300	Guarnizione collettore aria / Air manifold gasket / Luftkollektor Dichtung / Joint collecteur air / Burlete del colector aire
24	4141181424100	Fianco sx black / L. side black / Seite L. Schwarz / Côté G. noir / Lateral IZDO negro
24	4141181424101	Fianco sx silver / L. side silver / Seite L. Silver / Côté G. Silver / Lateral IZDO Silver
25	4141181204000	Supporto top nero / Top support-Black / Deckelhaltebügel-Schwarz / Support du dessus noir / Soporte del top negro
26	4141181273000	Lamiera posteriore / Back sheet / Hintere Platte / Tôle posterieure / Hoja posterior
27	4180180071000	Rete protezione / Protection grid / Schutznetz / Grillage protection / Red protección
28	41801800600	Magnete / Magnet / Magnet / Aimant / Imán
29	41801208002	Guarnizione - 2,5 m / Gasket - 2,5 m / Dichtung - 2,5 m / Joint - 2,5 m / Junta - 2,5 m
29	41801208000	Guarnizione - 5 m / Gasket - 5 m / Dichtung - 5 m / Joint - 5 m / Junta - 5 m
29	41801208001	Guarnizione - 50 m / Gasket - 50 m / Dichtung - 50 m / Joint - 50 m / Junta - 50 m
30	437018031	Assieme carrello top / Top trolley / Top Wagen / Top roulante / Carrito top
31	41201704500	Supporti antivibranti (10pz) / Anti-vibration supports (10pcs) / Schwingungsdämpfend Halterungen (10 Stck.) / Suport pour éléments antivibrations (10 pcs) / Apoyo anti-vibraciones (10 pzs)
32	4130170320100	Top in ghisa / Cast iron top / Top aus Gusseisen / Dessus en fonte / Top de arrabio
33	41801803500	Maniglia / Handle / Griff / Poignée / Maneta

## LOOP AIR 8 M1

Porta fuoco / Fire door / Feuertür / Porte foyer / Puerta hogar

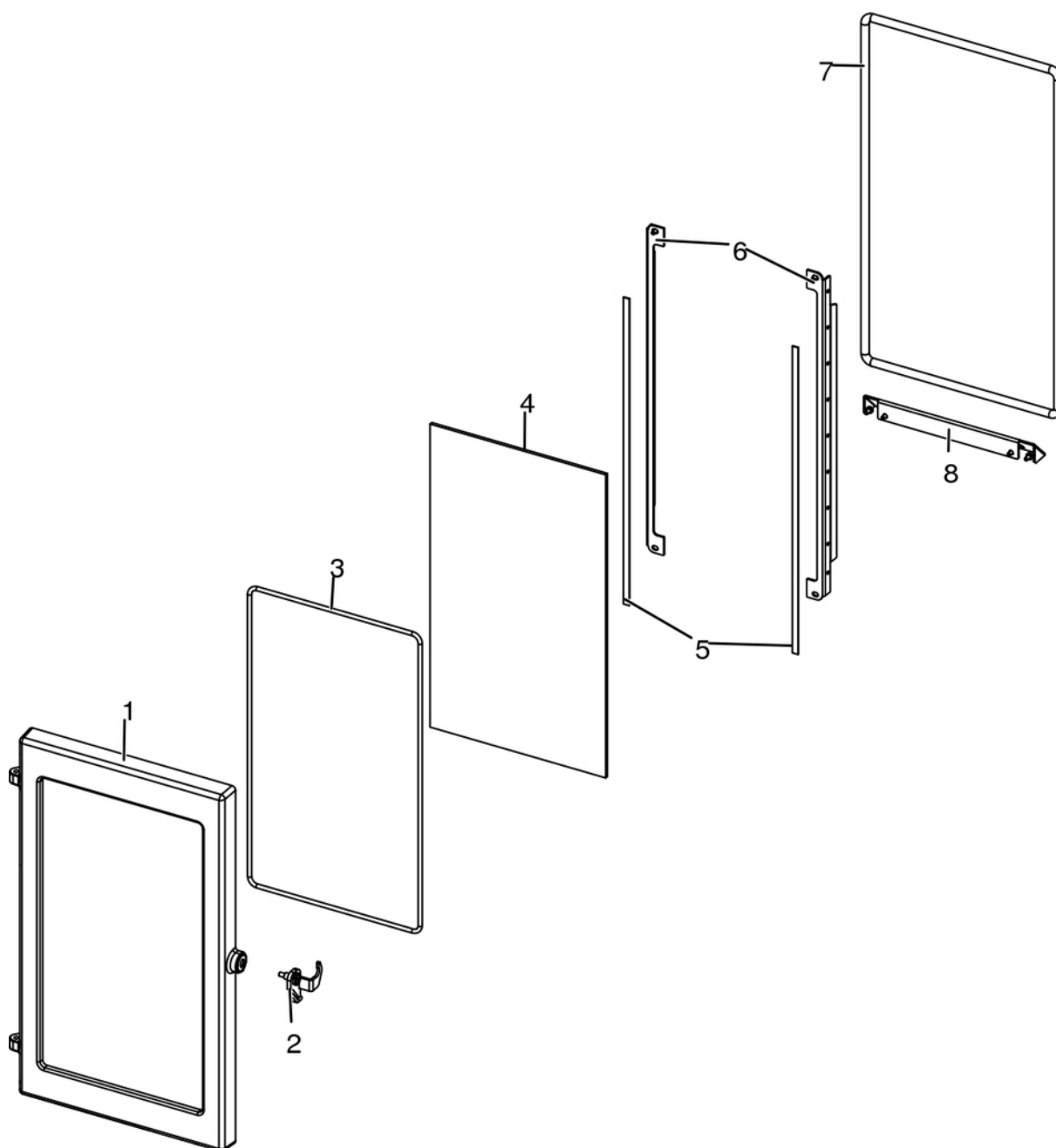

N°	Codice/Code	Descrizioni / Description / Beschreibung / Description / Description
1	41301602500V	Telaio porta fuoco / Fire door frame / Feuertürrahmen / Cadre foyer / Armazón puerta de arrabio
2	41411616560	Maniglia porta nera / Door Handle / Türgriff / Poignée porte / Tirador
3	41801603300A	Guarnizione Ø5 5mt / Gasket Ø5 5mt / Dichtung Ø5 5mt / Joint Ø5 5mt / Junta Ø5 5mt
3	41801603300B	Guarnizione Ø5 50mt / Gasket Ø5 50mt / Dichtung Ø5 50mt / Joint Ø5 50mt / Junta Ø5 50mt
3	41801603300C	Guarnizione Ø5 5mt + silicone / Gasket Ø5 5mt + silic / Dichtung Ø5 5mt + Silikon / Joint Ø5 5mt + silic / Junta Ø5 5mt
4	41701600300	Vetroceramico porta ghisa / Cast iron door glass / Glaskeramikscheibe Tür aus Gusseise / Vitrocéremique porte en fonte / Cristal cerámico puerta en arrabio
5	4120573A	Guarnizione a nastro 8 mm (5 mt.) per porta / Door strip gasket 8 mm (5 m) / Türbanddichtung 8 mm (5 m) / Joint ruban 8 mm (5 m) pour porte / Guarnición de cinta para puerta 8 mm (5 m)
5	4120573B	Guarnizione a nastro 8 mm (50 mt.) per porta / Door strip gasket 8 mm (50 m) / Türbanddichtung 8 mm (50 m) / Joint ruban 8 mm (50 m) pour porte / Guarnición de cinta para puerta 8 mm (50 m)

<b>6</b>	<b>41411622030V</b>	Profilo fermavetro / Fastening bracket profile / Haltebügel für Scheibebefestigung Profil / Profil patte de fixation / Perfil fermacristal
<b>7</b>	<b>4120104A</b>	Cordino fibroceramico Ø 12 mm (5 mt.) / Ceramic fibre cord Ø 12 mm (5 m.) / Keramikfaserschnur Ø 12 mm (5 m) / Cordon en fibre céramique Ø 12 mm (5 m) / Junta a cuerda de fibra cerámica Ø 12 mm (5 m)
<b>7</b>	<b>4120104B</b>	Cordino fibroceramico Ø 12 mm (50 mt.) / Ceramic fibre cord Ø 12 mm (50 m.) / Keramikfaserschnur Ø 12 mm (50 m) / Cordon en fibre céramique Ø 12 mm (50 m) / Junta a cuerda de fibra cerámica Ø 10 mm (52 m)
<b>7</b>	<b>41201041</b>	Kit sostituzione cordino (cordino+silicone) Ø 12 mm / Cord replacement kit (cord + silicon) Ø 12 mm / Schnuraustauschsatz (Schnur+Silikon) Ø 12 mm / Kit remplacement cordon (cordon + silicone) Ø 12 mm / Kit sustitución junta a cuerda (junta a cuerda+silicón) Ø 12 mm
<b>8</b>	<b>41411622130V</b>	Scivolo cenere / Ash ramp / Aschenrutsche / Glissière cendre / Tobogán ceniza

## LOOP AIR 8 M1

Gruppo camera di combustione / Combustion chamber group / Verbrennungskammer Gruppe / Group de chambre de combustion / Grupo cámara de combustión

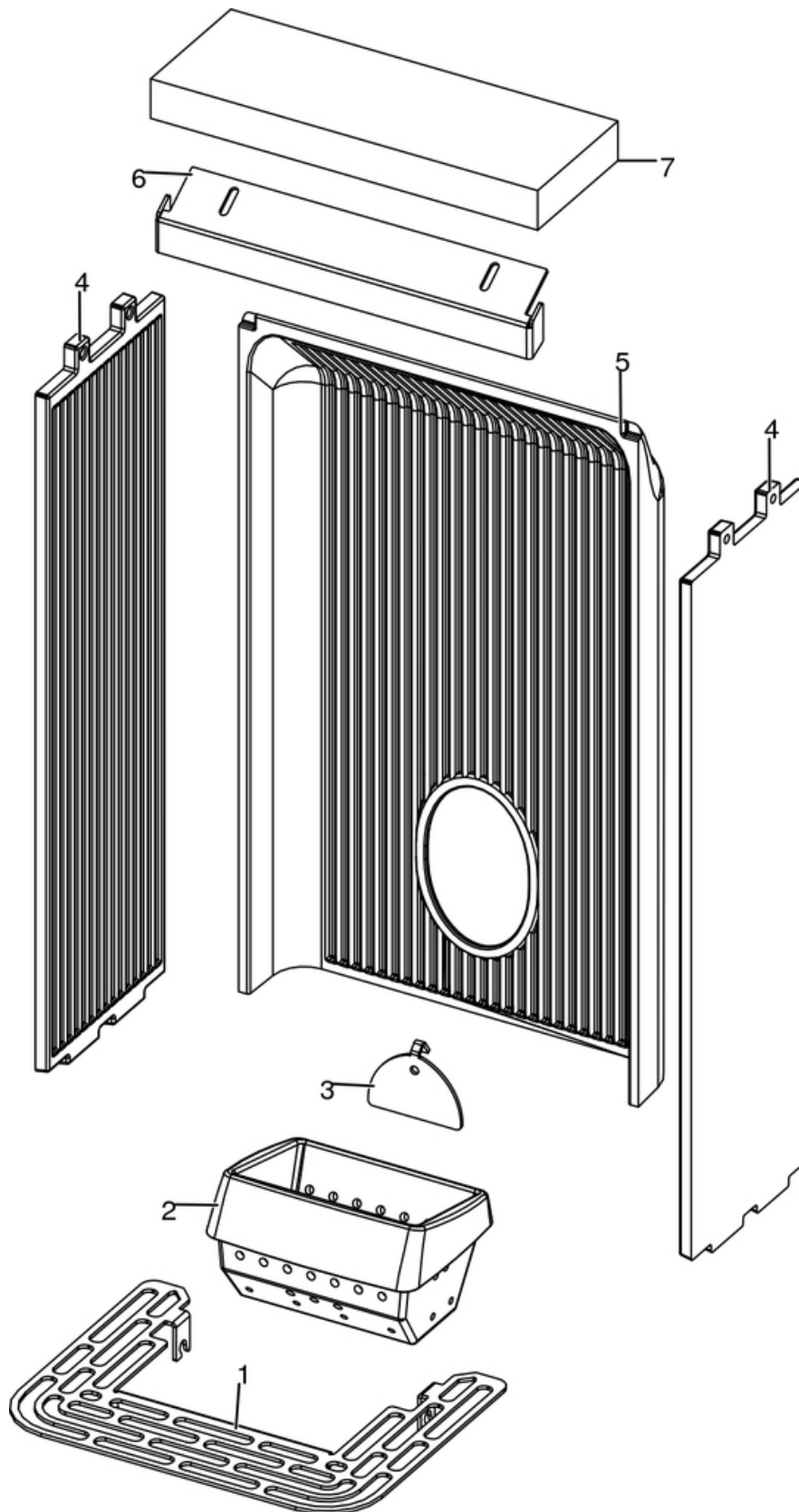

N°	Codice/Code	Descrizioni / Description / Beschreibung / Description / Descripcion
1	41411634830V	Griglia focolare / Fire Box Grille / Feuerstellenrost / Grille Foyer / Rejilla Hogar
2	41301502400V	Braciere ghisa / Cast iron grate / Brennertopf aus Gusseisen / Brasero en fonte / Brasero en arrabio
3	41411613530V	Deflettore pellet / Pellet deflector / Pellet Leitblech / Deflecteur pellet / Deflector pellet
4	41301502500V	Fianco ghisa / Cast iron side / Seite aus Guß / Côté en fonte / Placa lateral de arrabio
5	41301502600V	Schiena ghisa / Cast iron back / Rückwand aus Gusseisen / Dossieret en fonte / Parte trasera en arrabio
6	41411615430V	Deflettore aria / Air deflector / Luftleitblech / Déflecteur aire / Deflector aire
7	41151600200	Deflettore focolare in vermiculite / Vermiculite deflector / Leitblech aus Vermiculite / Déflecteur en vermiculite / Deflector en vermiculite

## LOOP AIR 8 M1

Gruppo accensione / Ignition group / Entzündung Gruppe / Groupe d'allumage / Grupo ignición

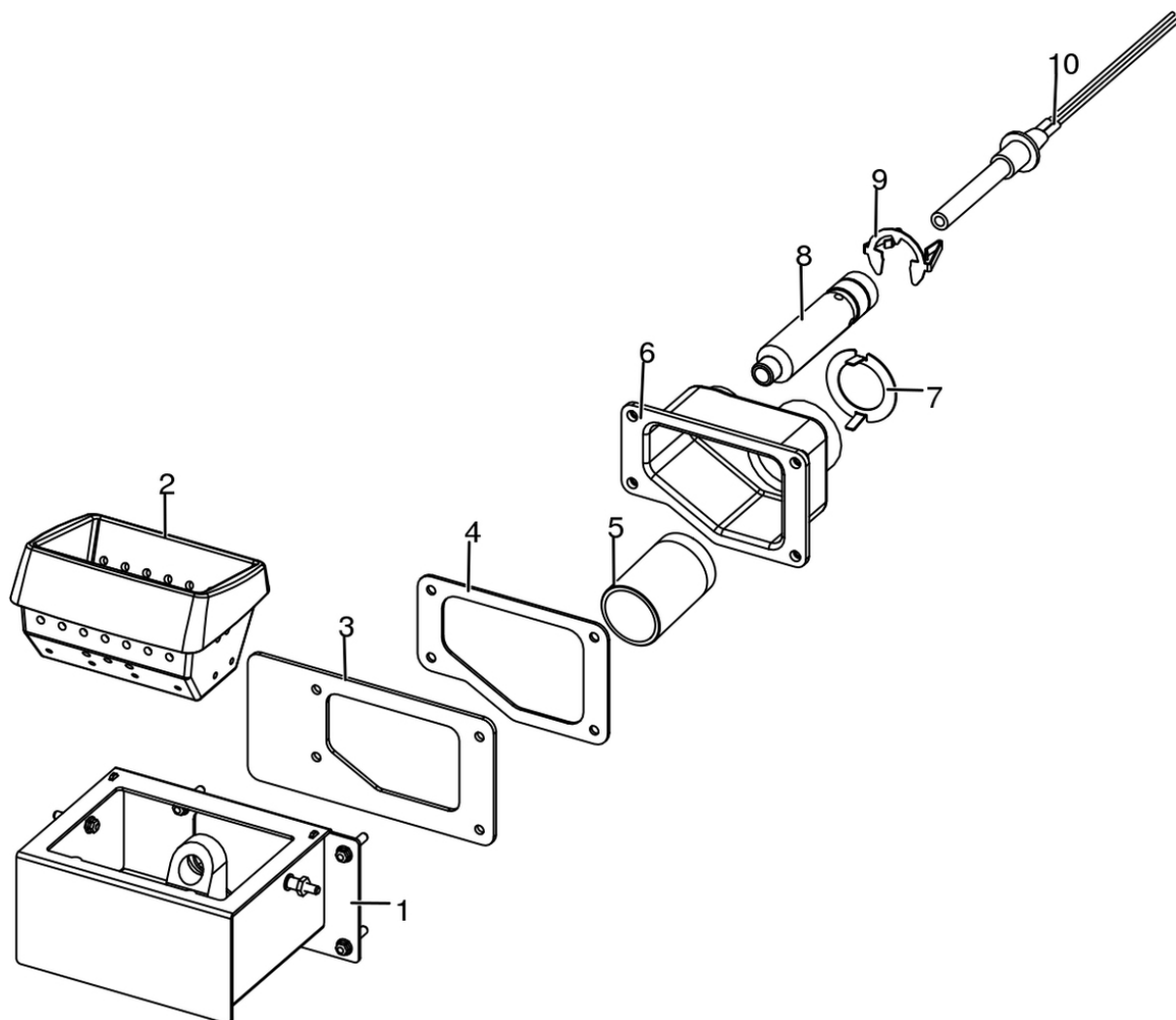

N°	Codice/Code	Descrizioni / Description / Beschreibung / Description / Descripción
1	41411613140V	Tasca braciere / Combustion pot container / Brenntopfkasten / Récipient brasero / Contenidor brasero
2	41301502400V	Braciere ghisa / Cast iron grate / Brennertopf aus Gusseisen / Brasero en fonte / Brasero en arrabio
3	41801601500	Guarnizione tasca braciere / Combustion pot container gasket / Brenntopfkasten Dichtung / Joint récipient brasero / Junta contenidor brasero
4	41801602300	Guarnizione codolo / Gasket / Dickung / Joint / Junta
5	41501701599	Manicotto potenziamento accensione / Combustion air extension pipe / Zusatzrohr für Nachrüstung / Tuyau amélioration allumage / Tubo impulso de encendido
6	41311803500	Codolo / Tool chuck / Einspannschaft / Outil d'emmanchement / Mango
7	41401629410	Regolatore ingresso aria comburente / Combustion air intake adjuster / Regler Eingang Verbrennungsluft / Régulateur arrivée air comburant / Regulador entrada aire comburente
8	41601601000	Condotto candeledda / Sparkplug Conduit / Zündkerzenkanal / Conduit Bougie / Conducto Bujía
9	41201601500	Anello arresto candeledda / Sparkplug stop / Zündkerzestopper / Butée bougie / Tope bujía
10	41451308101	Candeledda 315 Watt / Sparkplug 315 Watt / Zündkerze 315 Watt / Bougie 315 Watt / Bujía 315 Watt
10	41451308150	Kit 25 candeledda 315 Watt / 25 Sparkplugs 315 Watt kit / Bausatz 25 Zündkerzen 315 Watt / Kit 25 Bougies 315 Watt / Kit 25 Bujías 315 Watt

## LOOP AIR 8 M1

Gruppo caricamento pellet / Pellet feed group / Pellet Fördergruppe / Groupe chargement du pellet / Grupo de carga pellet

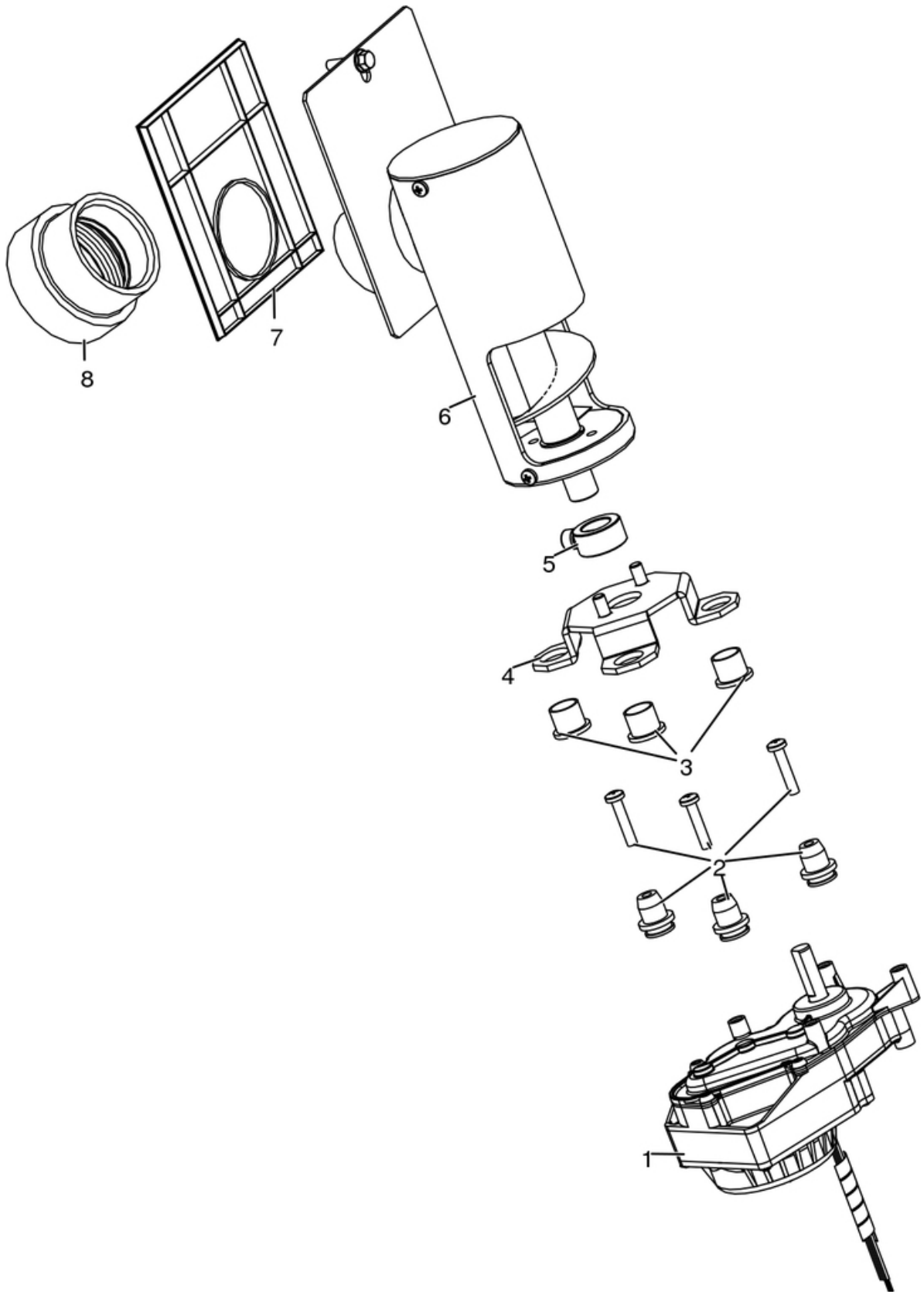



N°	Codice/Code	Descrizioni / Description / Beschreibung / Description / Descripción
1	41451702200	Motoriduttore brushless / Brushless reduction motor / Brushless Getriebemotor / Motoréducteur brushless / Motorreductor brushless
2	41801703700	Gommini antivibrante / Vibration damper rubber / Rammschutz Gummi / Caoutchouc antivibratoire / Cauchitos antivibración
3	41201800700	Boccola (3 pz) / Bushing (3 pcs) / Buchse (3 Stk) / Douille (3 pcs) / Abrazadera (3 pzs)
4	41411779331	Supporto coclea "Ragno" / Pellet feed screw bracket "spider" / "Spinne" Schenke Gestell / Support vis sans fin "Araignée" / Soporte coclea "Araña"
5	4120398	Connettore motoriduttore-coclea / Reduction motor-feed screw connector / Verbindung Getriebemotor-Schnecke / Connecteur motoréducteur-vis sans fin / Conector motorreductor-cóclea
6	41411800151	Gruppo alimentazione completo / Complete feed screw / Komplette Förderschnecke / Vis sans fin complète / Coclea de carga completa
7	41801600400	Guarnizione gruppo caricamento / Gasket / Dichtung / Joint / Junta
8	41801702600	Disaccoppiatore mesc. Marrone / Brown disengaging device / Braun Verängungsrohr / Tuyau de découplage maron / Tubo de desvío marron

## LOOP AIR 8 M1

Gruppo aria comburente / Combustion air group / Verbrennungsluft Gruppe / Groupe air comburant / Grupo aire comburente

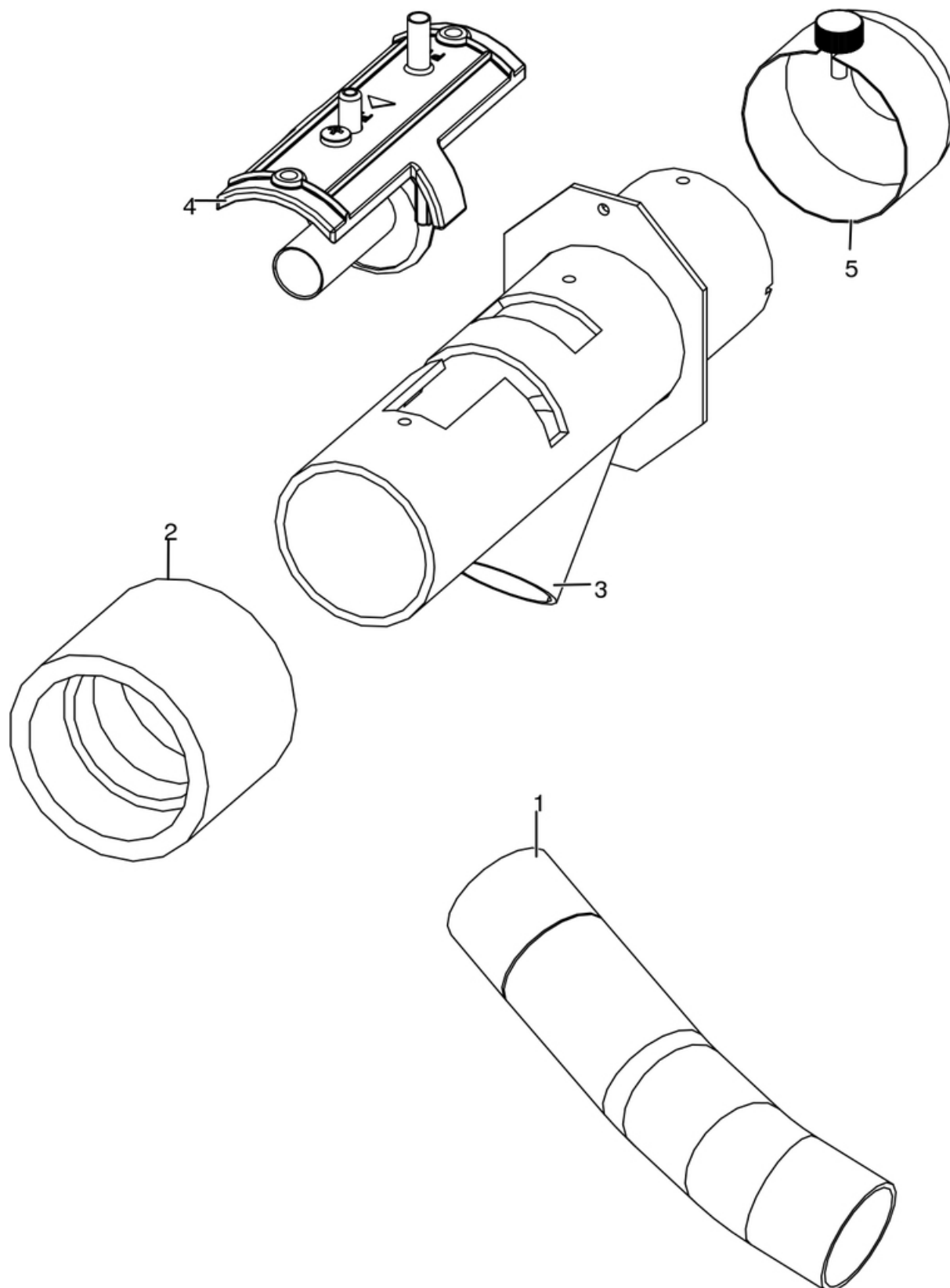

N°	Codice/Code	Descrizioni / Description / Beschreibung / Description / Descripción
1	41801601900	Tubo aspirazione pulizia vetro / Inlet pipe for cleaning glass air / Glassreinigungslufteingangsrohr / Tuyau entrée pour l'aire de nettoyage du vitre / Tubo entrada por l'aire de limpieza vidrio
2	41201707900	Manicotto in gomma / Rubber pipe / Gummi Zusatzrohr / Tuyau gomme / Tubo en goma
3	41601604461	Tubo aspirazione / Air inlet pipe / Lufteingangsrohr / Tuyau entrée d'air / Tubo entrada aire
4	41601301850	Componente rilevamento portata aria / Air flow measure component / Bauteil für Messung der Luftmenge / Composent pour la mesuration de la quantité d'air / Componente por la medida de l'aire
5	41401036100	Filtro antipolvere / Anti-dust filter / Staubschutzfilter / Filtre antipoussière / Filtro de protección polvo

## LOOP AIR 8 M1

Gruppo elettrico ed elettronico fino al SN 2103180010006 / Electrical and electronic group up to SN 2103180010006 / Elektrische und elektronische Gruppe bis zur SN 2103180010006 / Groupe électrique et électronique jusqu'au NS 2103180010006 / Grupo eléctrico y electrónico hasta NS 2103180010006

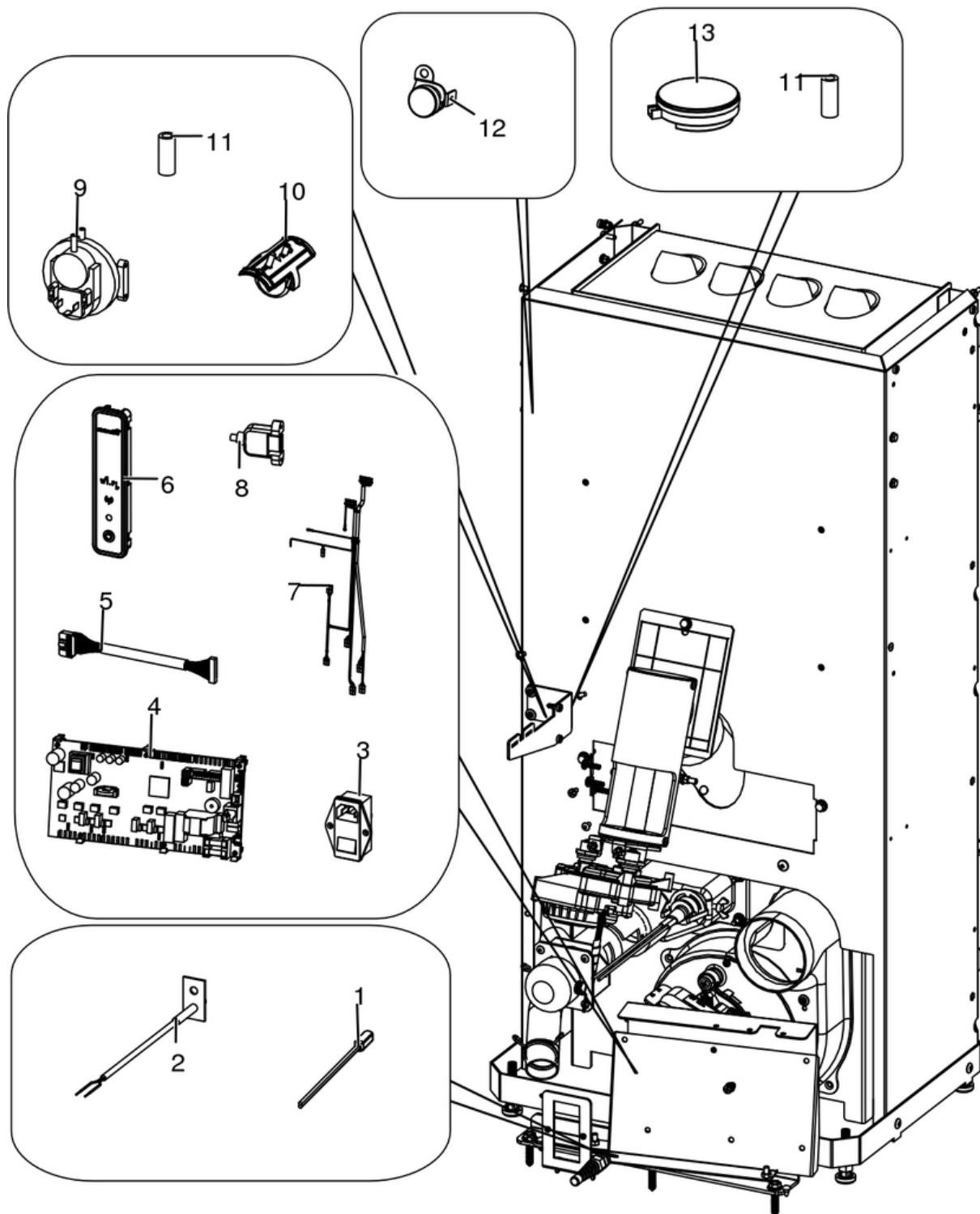

N°	Codice/Code	Descrizioni / Description / Beschreibung / Description / Descripción
1	4160386	Sonda temperatura ambiente/acqua / Room/Water temperature sensor / Raum- Wassertemperaturfühler / Sonde température ambiance/eau / Sonda temperatura ambiente/agua
2	41451703600	Sonda fumi con flangia con morsettiera L.980 / Smoke sensor with flange with terminal board L.980 / Rauchsonde mit Flansche mit Klemmenbrett L.980 / Sonde fumées avec bride avec serre-câble L.980 / Sonda humos con brida

		con borne L.980
<b>3</b>	<b>4160193</b>	Pulsante accensione / On/Off button / Zündungstaste / Touche d'allumage / Botón encendido
<b>4</b>	<b>41451802200</b>	Scheda elettronica / Electronic board / Elektronische Platine / Carte electronique / Tarjeta electronica
<b>5</b>	<b>41451801600</b>	Cavo flat 20 vie L.600 mm / Flat cable 20 pin L.600 mm / Flat-Kabel 20polig L.600 mm / Cable flat 20 voies L.600 mm / Flat cable 20 vias L.600 mm
<b>6</b>	<b>41451602802</b>	Pannello di emergenza Wireless / Wireless emergency display / Wireless Notfall-Blende / Panneau d'urgence wireless / Panel emergencia wireless
<b>7</b>	<b>41451801400</b>	Cablaggio / Wiring / Verdrahtung / Cablage / Cableado
<b>8</b>	<b>41451403200</b>	Cavo USB da pannello L.500 / USB Cable from display L.500 / USB Kabel von Notfalldisplay L.500 / Câble USB de panneau L.500 / Cable USB del panel L.500
<b>9</b>	<b>41451003700</b>	Pressostato / Pressure switch / Druckschalter / Pressostat / Presostato
<b>10</b>	<b>41601301850</b>	Componente rilevamento portata aria / Air flow measure component / Bauteil für Messung der Luftmenge / Composent pour la mesuration de la quantité d'air / Componente por la medida de l'aire
<b>11</b>	<b>4120631A</b>	Tubicino siliconico - 5m / Silicon tube - 5m / Silikonrohr - 5m / Petit tuyau en silicone - 5m / Tubo silicónico - 5m
<b>12</b>	<b>412007004</b>	Clickson 110°C / Clickson 110°C / Clickson 110°C / Clickson 110°C / Clickson 110°C
<b>13</b>	<b>41451303400</b>	Trasduttore di pressione / Pressure transducer / Active-Wandler / Transducteur de pression / Transductor de pression

## LOOP AIR 8 M1

Gruppo elettrico ed elettronico dal SN 2103180010006 / Electrical and electronic group starting from SN 2103180010006 / Elektrische und elektronische Gruppe ab SN 2103180010006 / Groupe électrique et électronique à partir du NS 2103180010006 / Grupo eléctrico y electrónico a partir de NS 2103180010006

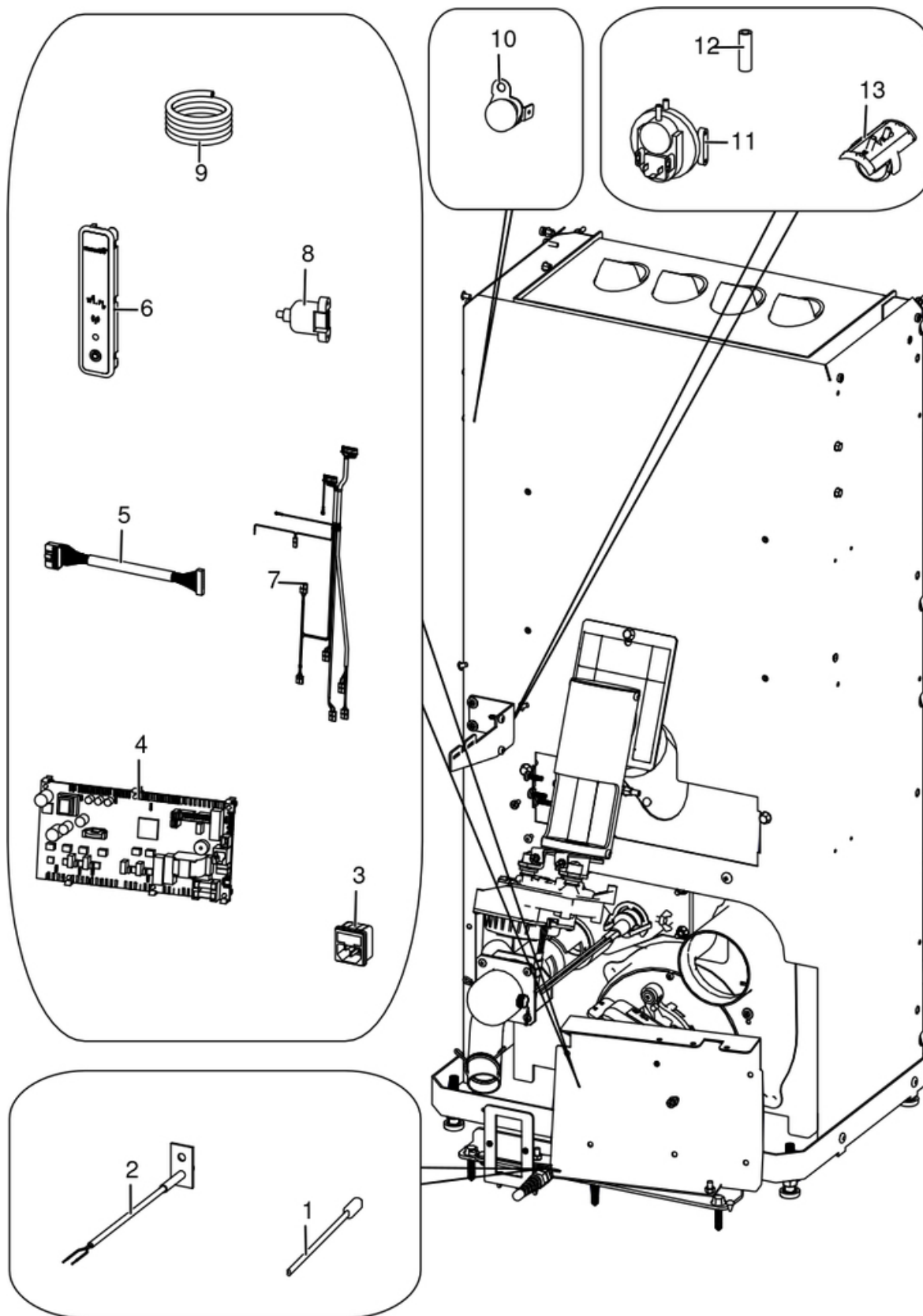

N°	Codice/Code	Descrizioni / Description / Beschreibung / Description / Descripción
1	4160386	Sonda temperatura ambiente/acqua / Room/Water temperature sensor / Raum- Wassertemperaturfühler / Sonde température ambiance/eau / Sonda temperatura ambiente/agua
2	41451703600	Sonda fumi con flangia con morsettiera L.980 / Smoke sensor with flange with terminal board L.980 / Rauchsonde mit Flansche mit Klemmenbrett L.980 / Sonde fumées avec bride avec serre-câble L.980 / Sonda humos con brida con borne L.980
3	41451104100	Presa con fusibile / Socket with fuse / Steckdose mit Sicherung / Prise avec fusible / Toma con fusible
4	41451904300	Scheda madre / Motherboard / Hauptplatine / Carte mère / Tarjeta madre
4	41451904300A	Sensirion / Sensirion / Sensirion / Sensirion / Sensirion
5	41451801600	Cavo flat 20 vie L.600 mm / Flat cable 20 pin L.600 mm / Flat-Kabel 20polig L.600 mm / Cable flat 20 voies L.600 mm / Flat cable 20 vias L.600 mm
6	41451602802	Pannello di emergenza Wireless / Wireless emergency display / Wireless Notfall-Blende / Panneau d'urgence wireless / Panel emergencia wireless
7	41451800302	Cablaggio elettrico / Electrical wiring / Elektrische Verkabelung / Câblage électrique / Cableado eléctrico
8	41451403200	Cavo USB da pannello L.500 / USB Cable from display L.500 / USB Kabel von Notfalldisplay L.500 / Câble USB de panneau L.500 / Cable USB del panel L.500
9	41801902500	Spirale Rilsan (30 m.) / Rilsan spiral (30 m.) / Spirale Rilsan (30 M.) / Spirale Rilsan (30 m.) / Espiral Rilsan (30 m.)
9	41801902500A	Spirale Rilsan (5 spire) / Rilsan spiral (5 coils) / Spirale Rilsan (5 Windungen) / Spirale Rilsan (5 spires) / Espiral Rilsan (5 espire)
10	412007004	Clickson 110°C / Clickson 110°C / Clickson 110°C / Clickson 110°C / Clickson 110°C
11	41451003700	Pressostato / Pressure switch / Druckschalter / Pressostat / Presostato
12	4120631A	Tubicino siliconico - 5m / Silicon tube - 5m / Silikonrohr - 5m / Petit tuyau en silicone - 5m / Tubo silicónico - 5m
13	41601301850	Componente rilevamento portata aria / Air flow measure component / Bauteil für Messung der Luftmenge / Composent pour la mesuration de la quantité d'air / Componente por la medida de l'aire

## LOOP AIR 8 M1

Gruppo fumi / Smoke group / Rauchgruppe / Groupe fumées / Grupo de humos

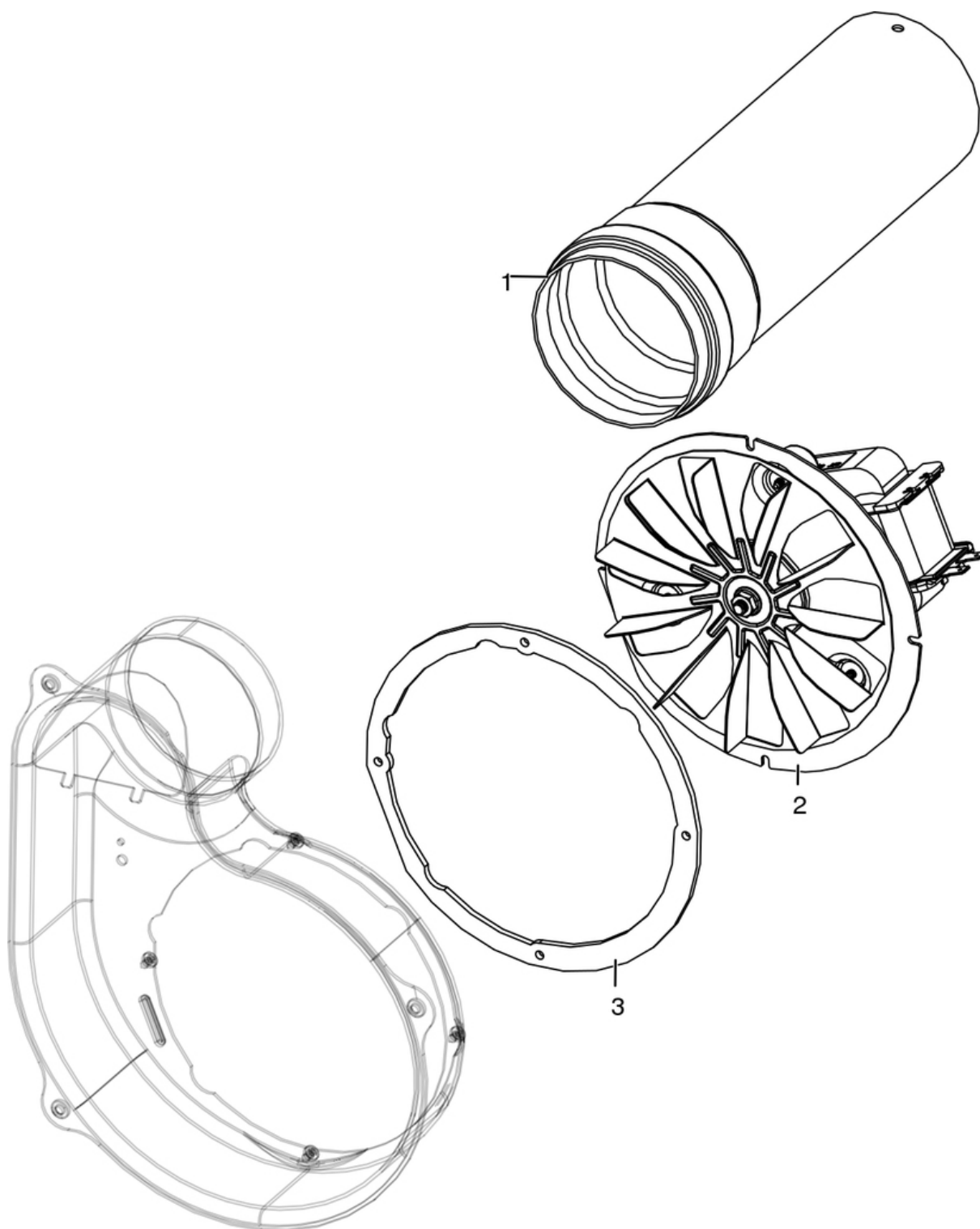

N°	Codice/Code	Descrizioni / Description / Beschreibung / Description / Descripcion
1	41601603000	Tubo Ø8 L.25 con guarnizione / Pipe Ø8 L.25 with gasket / Rohr Ø8 L.14 mit Dichtung / Tuyau Ø8 L.25 avec joint / Tubo Ø8 L.25 con guarnición
2	41451503200	Ventilatore fumi stagno / Air-tight smoke exhausted fan / Luftdichtes Rauchgasgebläse / Ventilateur fumées étanche / Ventilador humos hermético
2	41451703000	Encoder per ventilatore fumi marchio EBM / Encoder for EMB smoke fan / Encoder für EBM Rauchgasgebläse /



		Encoder pour ventilateur des fumées marque EBM / Encoder para ventilador humos marca EBM
<b>2</b>	<b>41451209300</b>	Encoder per ventilatore fumi marchi LN2/SIT / Encoder for LN2/SIT smoke fan / Encoder für LN2/SIT Rauchgasgebläse / Encoder pour ventilateur des fumées marques LN2/SIT / Encoder para ventilador humos marcas LN2/SIT
<b>2</b>	<b>41452009200</b>	Encoder ventilatore / Fan encoder / Lüfter Encoder / Encodeur de ventilateur / Codificador de ventilador
<b>3</b>	<b>41801600800</b>	Guarnizione ventilatore fumi / Smoke exhaust fan gasket / Dichtung Rauchabsauggebläse / Joint Ventilateur aspiration fumées / Junta ventilador aspiración humos

## LOOP AIR 8 M1

Gruppo ventilazione / Ventilation group / Lüftungsgruppe / Groupe de ventilation / Grupo de ventilación

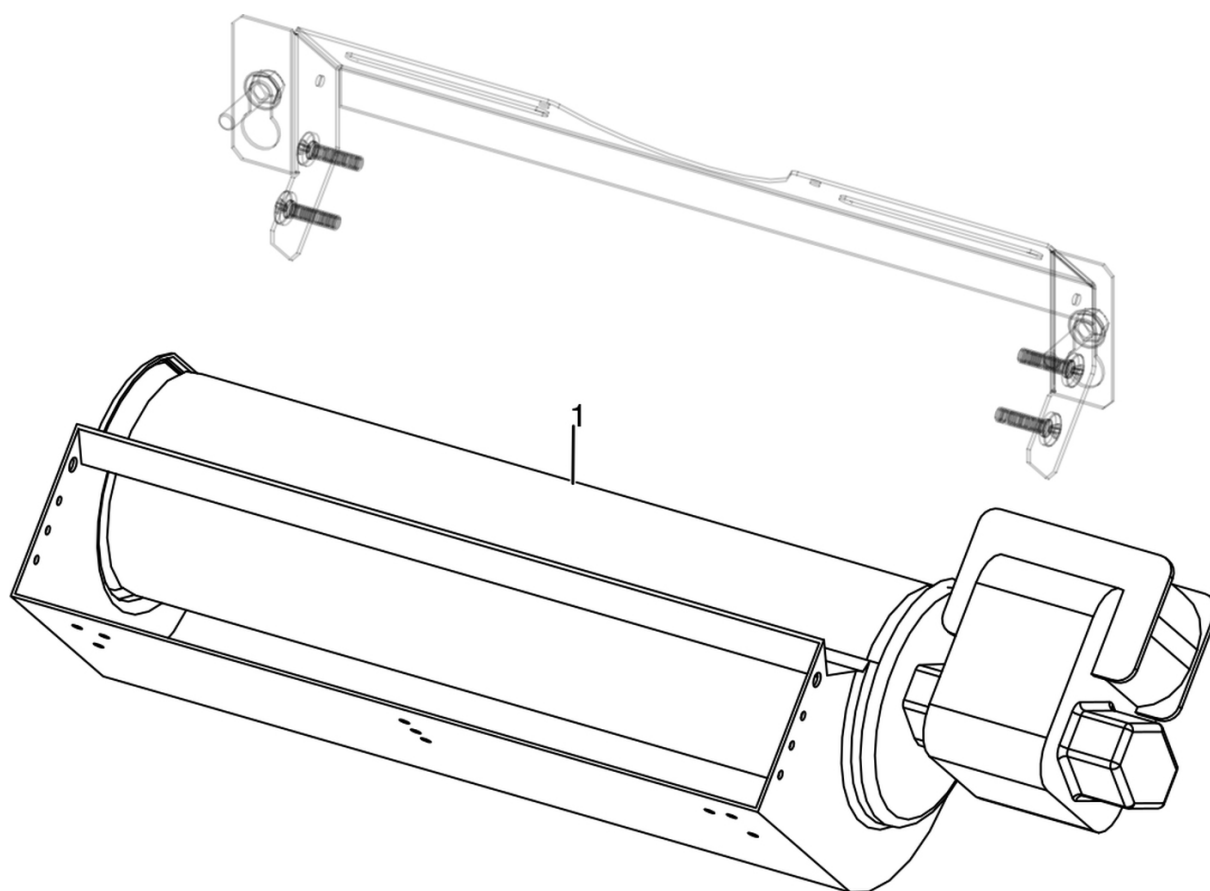

N°	Codice/Code	Descrizioni / Description / Beschreibung / Description / Descripción
1	41451600800	Ventilatore aria / Air fan / Luftgebläse / Ventilateur air / Ventilador aire