

TOBA HYDRO 22 HE

Componenti Struttura Esterna / External structure components / Bauteile Aussenkorpus / Composants structure externe / Componentes estructura externa

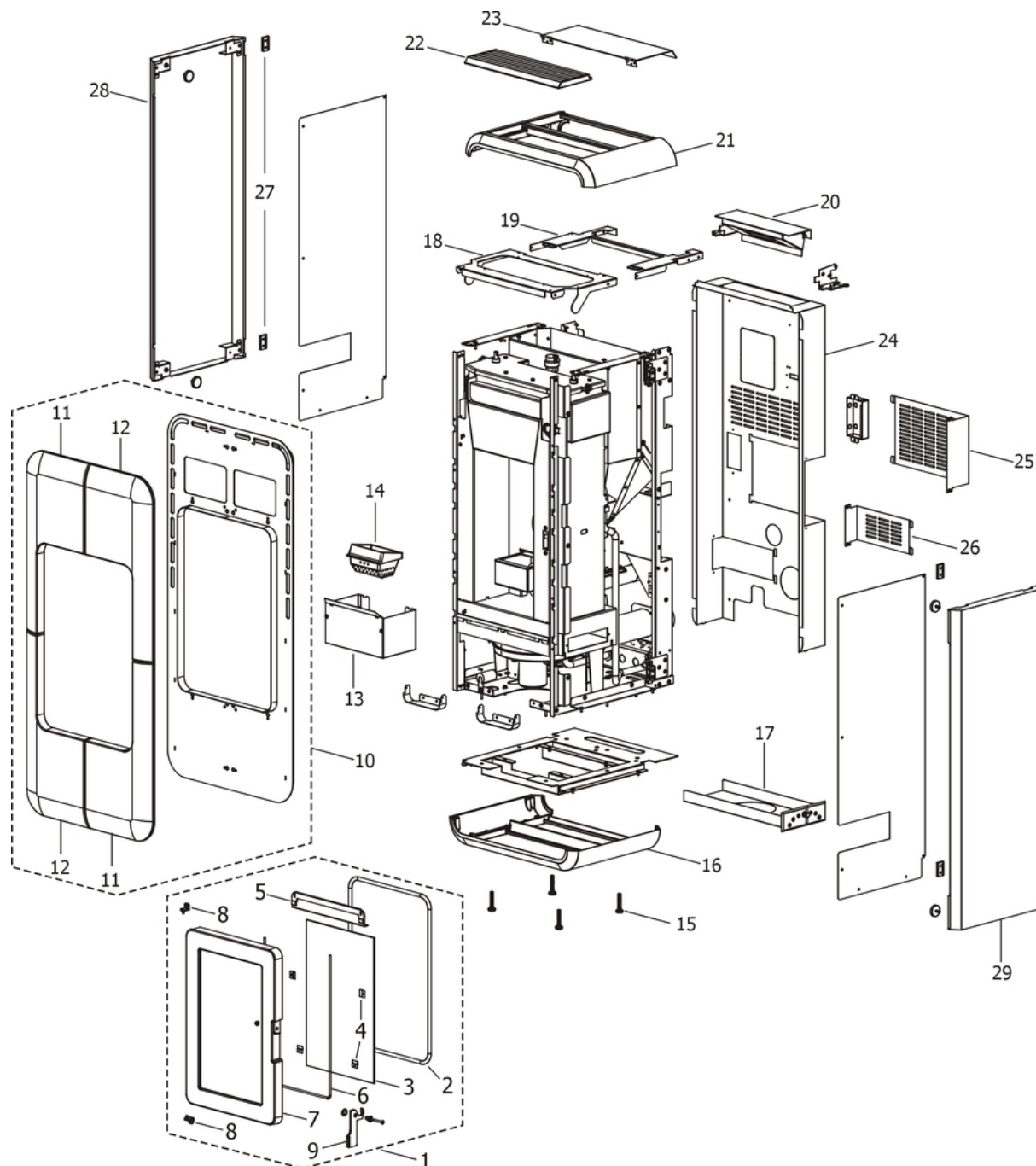

N°	Codice/Code	Descrizioni / Description / Beschreibung / Description / Descripción
1	41301301550	Porta fuoco completa in ghisa / Cast iron complete fire door / Komplette Feuertür aus Guß / Porte foyer complète en fonte / Puerta hogar completa de arrabio
2	41201031	Kit sostituzione cordino (cordino+silicone) Ø 10 mm / Cord replacement kit (cord + silicon) Ø 10 mm / Schnuraustauschsatz (Schnur+Silikon) Ø 10 mm / Kit remplacement cordon (cordon + silicone) Ø 10 mm / Kit sustitución junta a cuerda (junta a cuerda+silicón) Ø 10 mm
2	4120103A	Cordino fibroceramico Ø 10 mm (5 mt.) / Ceramic fibre cord Ø 10 mm (5 m) / Keramikfaserschnur Ø 10 mm (5 m) / Cordon en fibre céramique Ø 10 mm (5 m) / Junta a cuerda de fibra cerámica Ø 10 mm (5 m)
2	4120103B	Cordino fibroceramico Ø 10 mm (50 mt.) / Ceramic fibre cord Ø 10 mm (50 m) / Keramikfaserschnur Ø 10 mm (50 m) / Cordon en fibre céramique Ø 10 mm (50 m) / Junta a cuerda de fibra cerámica Ø 10 mm (50 m)
3	41700901060	Vetroceramico completo di guarnizione / Glass with gasket / Glaskeramikscheibe mit Dichtung / Vitrocéramique avec

		joint / Cristal cerámico con guarnición	
4	41401077430	Staffe di fissaggio vetroceramico (4 pz.) / Pyroceram fastening brackets (4 pcs.) / Befestigungsbügel Glaskeramik (4 Stck.) / Étrier de fixation vitrocéramique (4 pz.) / Abrazaderas de fijación vidrio cerámico (4 piezas)	
5	41411303330V	Deflettore / Deflector / Leitblech / Déflecteur / Deflector	
6	4120106	Guarnizione a nastro fireglass / Fireglass tape gasket / Banddichtung Fireglass / Joint ruban Fireglass / Guarnición a cinta Fireglass	
7	41301301650V	Telaio porta fuoco in ghisa / Cast iron fire door frame / Feuertürrahment aus Guß / Cadre porte foyer en fonte / Armazón puerta hogar de arrabio	
8	412008063	Cerniere porta fuoco (2 pz) / Fire door hinge (2pcs) / Scharnier Feuertür (2 Stck) / Charnière porte foyer (2 pcs) / bisagra puerta del hogar (2 pz)	
8	412008063	Cerniere porta fuoco (2 pz) / Fire door hinge (2pcs) / Scharnier Feuertür (2 Stck) / Charnière porte foyer (2 pcs) / bisagra puerta del hogar (2 pz)	
9	41400939760	Maniglia completa / Complete handle / Kompletter Griff / Poignée complète / Tirador completo	
10	41400945360	Telaio in acciaio nero / Black steel frame / Rahmen aus schwarzem Stahl / Cadre en acier noir / Marco en acero negro	
11	41250912150	Ceramica sup. Sx ed inf. Dx white / White upper L. LEFT and lower R. ceramic / Ober LI. und unten RE White Keramik / Céramique sup. G. et inf. D. white / Cerámica sup. IZDA e inf. DCHA white	
11	41250912150	Ceramica sup. Sx ed inf. Dx white / White upper L. LEFT and lower R. ceramic / Ober LI. und unten RE White Keramik / Céramique sup. G. et inf. D. white / Cerámica sup. IZDA e inf. DCHA white	
11	41250912350	Ceramica sup. SX ed inf. DX - BORDEAUX / Upper ceramic LEFT and lower RIGHT - BORDEAUX / Obere Keramik LI. und unten RE. - BORDEAUX / Céramique sup. GAUCHE et inf. DROITE - BORDEAUX / Cerámica sup. IZDA e inf. DCHA - BORDEAUX	
11	41250912350	Ceramica sup. SX ed inf. DX - BORDEAUX / Upper ceramic LEFT and lower RIGHT - BORDEAUX / Obere Keramik LI. und unten RE. - BORDEAUX / Céramique sup. GAUCHE et inf. DROITE - BORDEAUX / Cerámica sup. IZDA e inf. DCHA - BORDEAUX	
11	41250912450	Ceramica sup. SX ed inf. DX - BLACK / Upper ceramic LEFT and lower RIGHT - BLACK / Obere Keramik LI. und unten.RE. - BLACK / Céramique sup. GAUCHE et inf. DROITE - BLACK / Cerámica sup. IZDA e inf. DCHA - BLACK	-
11	41250912450	Ceramica sup. SX ed inf. DX - BLACK / Upper ceramic LEFT and lower RIGHT - BLACK / Obere Keramik LI. und unten.RE. - BLACK / Céramique sup. GAUCHE et inf. DROITE - BLACK / Cerámica sup. IZDA e inf. DCHA - BLACK	-
11	41250912550	Ceramica sup. Sx ed inf. Dx Skin / Skin upper L. LEFT and lower R. ceramic / Ober LI. und unten RE. Skin Keramik / Céramique sup. G. et inf. D. Skin / Cerámica sup. IZDA e inf. DCHA Skin	
11	41250912550	Ceramica sup. Sx ed inf. Dx Skin / Skin upper L. LEFT and lower R. ceramic / Ober LI. und unten RE. Skin Keramik / Céramique sup. G. et inf. D. Skin / Cerámica sup. IZDA e inf. DCHA Skin	
11	41250914050	Soapstone sup. Sx ed inf. Dx / Upper L. and lower R. soapstone / Ober LI. und unten. RE. Soapstone / Soapstone sup. G. et inf. D. / Soapstone sup. IZDA e inf. DCHA	
11	41250914050	Soapstone sup. Sx ed inf. Dx / Upper L. and lower R. soapstone / Ober LI. und unten. RE. Soapstone / Soapstone sup. G. et inf. D. / Soapstone sup. IZDA e inf. DCHA	
11	41251103750	Ceramica sup. Sx ed inf. Dx Sandstone / Sandstone upper L. LEFT and lower R. ceramic / Ober LI. und unten RE Keramik Sandstone / Céramique sup. G. et inf. D. Sandstone / Cerámica sup. IZDA e inf. DCHA Sandstone	
11	41251103750	Ceramica sup. Sx ed inf. Dx Sandstone / Sandstone upper L. LEFT and lower R. ceramic / Ober LI. und unten RE Keramik Sandstone / Céramique sup. G. et inf. D. Sandstone / Cerámica sup. IZDA e inf. DCHA Sandstone	
12	41250913150	Ceramica sup. DX ed inf. SX White / White upper R. and lower L. ceramic / Obere RE. und unten LI. White Keramik / Céramique sup. D et inf. G. white / Cerámica sup. DCHA e inf. IZDA white	
12	41250913150	Ceramica sup. DX ed inf. SX White / White upper R. and lower L. ceramic / Obere RE. und unten LI. White Keramik / Céramique sup. D et inf. G. white / Cerámica sup. DCHA e inf. IZDA white	
12	41250913350	Ceramica sup. Dx ed inf. Sx bordeaux / Burgundy upper R. and lower L. ceramic / Obere RE. und unten LI. Keramik bordeaux / Céramique sup. D. et inf. G. bordeaux / Cerámica sup. DCHA e inf. IZDA burgundi	
12	41250913350	Ceramica sup. Dx ed inf. Sx bordeaux / Burgundy upper R. and lower L. ceramic / Obere RE. und unten LI. Keramik bordeaux / Céramique sup. D. et inf. G. bordeaux / Cerámica sup. DCHA e inf. IZDA burgundi	
12	41250913450	Ceramica sup. Dx ed inf. Sx Black / Black upper R. and lower L. ceramic / Obere RE. und unten LI. Black Keramik / Céramique sup. D. et inf. G. black / Cerámica sup. DCHA e inf. IZDA black	
12	41250913450	Ceramica sup. Dx ed inf. Sx Black / Black upper R. and lower L. ceramic / Obere RE. und unten LI. Black Keramik / Céramique sup. D. et inf. G. black / Cerámica sup. DCHA e inf. IZDA black	
12	41250913550	Ceramica sup. DX ed inf. SX Skin / Skin upper R. and lower L. ceramic / Obere RE. und unten LI. Skin Keramik / Céramique sup. D et inf. G. Skin / Cerámica sup. DCHA e inf. IZDA Skin	
12	41250913550	Ceramica sup. DX ed inf. SX Skin / Skin upper R. and lower L. ceramic / Obere RE. und unten LI. Skin Keramik / Céramique sup. D et inf. G. Skin / Cerámica sup. DCHA e inf. IZDA Skin	
12	41250914150	Soapstone sup. DX ed inf. SX / Upper R. and lower L. Soapstone / Ober Re. und unten LI. Soapstone / Soapstone sup. D. et inf. G. / Soapstone sup. DCHA e inf. IZDA	
12	41250914150	Soapstone sup. DX ed inf. SX / Upper R. and lower L. Soapstone / Ober Re. und unten LI. Soapstone / Soapstone sup. D. et inf. G. / Soapstone sup. DCHA e inf. IZDA	
12	41251103850	Ceramica sup. DX ed inf. SX Sandstone / Sandstone upper R. and lower L. ceramic / Obere RE. und unten LI.	

		Keramik Sandstone / Céramique sup. D et inf. G. Sandstone / Cerámica sup. DCHA e inf. IZDA Sandstone
12	41251103850	Ceramica sup. DX ed inf. SX Sandstone / Sandstone upper R. and lower L. ceramic / Obere RE. und unten LI. Keramik Sandstone / Céramique sup. D et inf. G. Sandstone / Cerámica sup. DCHA e inf. IZDA Sandstone
13	41400915531V	Cassetto cenere / Ash drawer / Aschenkasten / Tiroir à cendres / Cajón ceniza
14	413008003	Braciere completo in ghisa / Cast iron complete grate / Kompletter Brennerkopf aus Gusseisen / Brasero complet en fonte / Brasero completo de arrabio
15	41200906660	Piedini di appoggio (4 pz.) / Support feet (4 pcs.) / Einstellfüße (4 Stck.) / Vérins d'appui (4 p.es) / Pies de apoyo (4 piezas)
16	41310900660	Base in acciaio nero verniciato / Black painted base / Basis aus Stahl Schwarz lackiert / Base en acier laqué noir / Base en acero negro barnizado
17	41411300430	Cassetto cenere inferiore / Lower ash drawer / Untere Aschenkasten / Tiroir à cendres inférieur / Cajón ceniza inferior
18	41411300930V	Supporto top anteriore / Frontal top support / Vordere Deckelhaltebügel / Support du dessus antérieur / Soporte top anterior
19	41411300830	Supporto top posteriore / Rear top support / Hintere Deckelhaltebügel / Support du dessus postérieur / Soporte top posterior
20	41411302250	Supporto pannello comandi / Display stand / Fassung für Bedienblende / Support panneau des commandes / Soporte panel de mandos
21	41310900160	Top in acciaio nero verniciato / Black painted steel top / Abdeckplatte aus Stahl Schwarz lackiert / Dessus en acier laqué noir / Top en acero negro barnizado
22	41310900260	Griglia uscita aria calda / Hot air outlet grille / Gitter Wärmeluftaustritt / Grille sortie air chaud / Rejilla salida aire caliente
23	41400945960	Coperchio serbatoio pellet / Pellet hopper cover / Deckel Pelletbehälter / Couvercle réservoir pellet / Tapa depósito pellet
24	41411302660	Schiena posterior / Rear back / Hintere Rückwand / Dossieret postérieur / Parte trasera
25	41411302760	Coperchio scheda madre / Motherboard cover / Hauptplatine Deckel / Couvercle carte mère / Tapa tarjeta madre
26	41411302860	Coperchio pompa circolazione / Pump cover / Pumpe Deckel / Couvercle pompe de circulation / Tapa bomba de circulación
27	41201104500	Cerniera pz.2 / Hinge Pcs.2 / Scharnier St.2 / Charnière Pcs.2 / Bisagra Pz.2
28	41411302360	Fianco nero / Black side / Schwarze Seite / Côté noir / Lateral negro
29	41411302360	Fianco nero / Black side / Schwarze Seite / Côté noir / Lateral negro

TOBA HYDRO 22 HE

Componenti interni meccanici ed elettronici / Electronic and mechanic internal parts / Interne mechanische und elektronische Bauteile / Composants internes mécaniques et électroniques / Componentes internos electrónicos y mecánicos

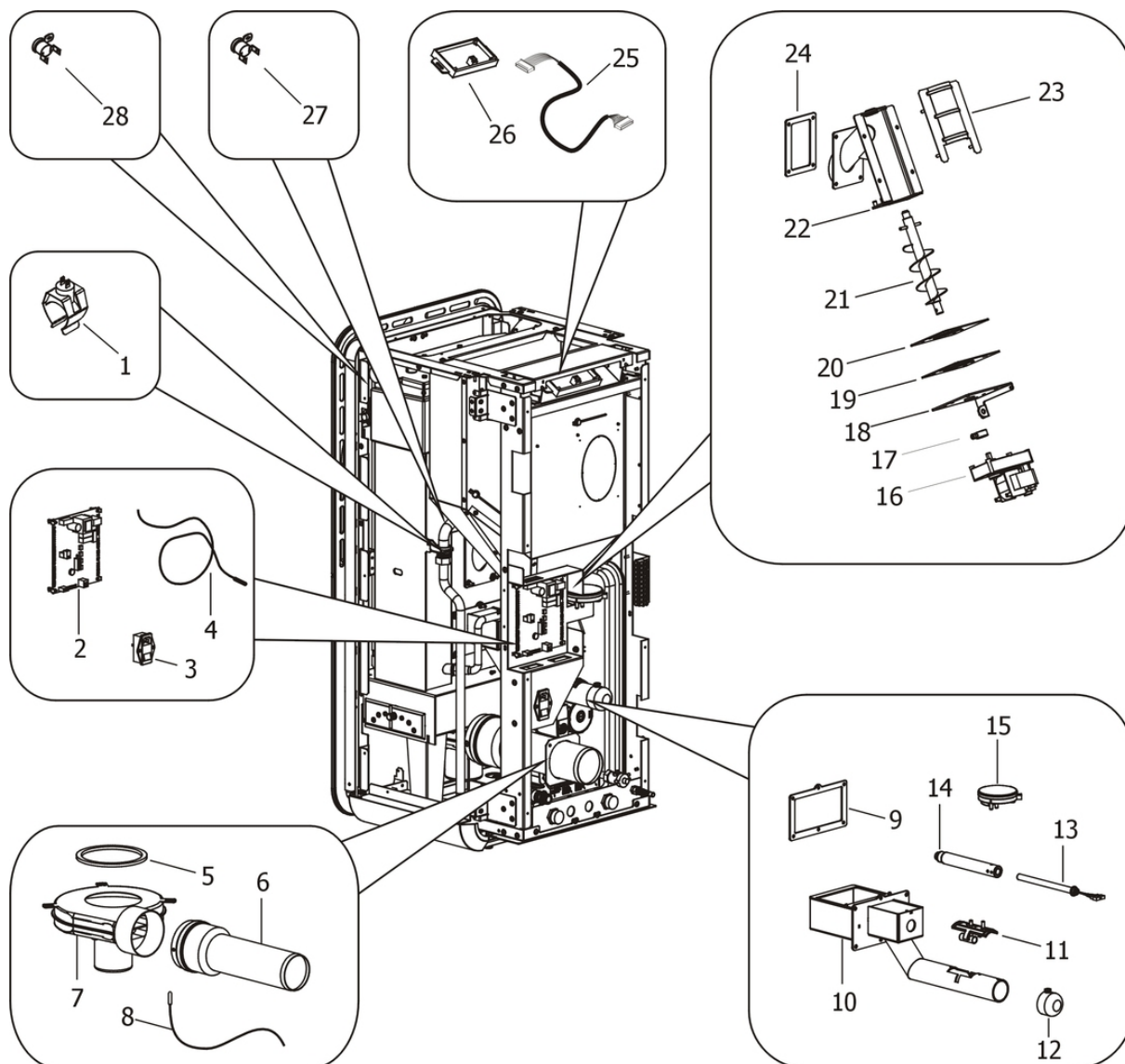

N°	Codice/Code	Descrizioni / Description / Beschreibung / Description / Description
1	41450901200	Sonda temperatura acqua / Water temperature sensor / Wassertemperaturfühler / Sonde température eau / Sonda temperatura agua
2	41451303805	Scheda madre Hottoh 149 / Hottoh motherboard 149 / Hauptplatine Hottoh 149 / Carte mère Hottoh 149 / Tarjeta madre Hottoh 149
3	4160193	Pulsante accensione / On/Off button / Zündungstaste / Touche d'allumage / Botón encendido
4	4160386	Sonda temperatura ambiente/acqua / Room/Water temperature sensor / Raum- Wassertemperaturfühler / Sonde température ambiance/eau / Sonda temperatura ambiente/agua
5	41801100100	Guarnizione adesiva voluta fumi / Adhesive gasket smoke volute / Haftenddichtung Rauchvolute / Joint adhesive volute fumées / Junta adhesiva voluta humos
6	41601205960	Tubo uscita fumi / Smoke outlet pipe / Rohr Rauchabzug / Tuyau sortie fumées / Tubo salida humos
7	41451100300	Ventilatore aspirazione fumi con encoder / Smoke exhausted fan WITH encoder / Rauchabsauggebläse MIT Encoder / Ventilateur aspiration fumées AVEC encoder / Ventilador aspiración humos con codificador
7	41801803900	Guarnizione ø212 / Gasket ø212 / Dichtung ø212 / Joint ø212 / Junta ø212
7	41452009200	Encoder ventilatore / Fan encoder / Lüfter Encoder / Encodeur de ventilateur / Codificador de ventilador
8	41451002300	Sonda fumi con flangia / Smoke sensor with flange / Rauchgasfühler mit Flansche / Sonde fumées avec bride /

		Sonda humos con arandela
9	418008027	Guarnizione / Gasket / Dichtung / Joint / Junta
10	41411301640V	Tasca braciere / Combustion pot container / Brenntopfkasten / Récipient brasero / Contenedor brasero
11	41601305050	Componente rilevamento portata aria / Air flow measure component / Bauteil für Messung der Luftmenge / Composant pour la mesuration de la quantité d'air / Componente por la medida de l'aire
12	41401036100	Filtro antipolvere / Anti-dust filter / Staubschutzfilter / Filtre antipoussière / Filtro de protección polvo
13	41450905000	Candeletta accensione pellet / Pellet ignition sparkplug / Zündkerze Pelletzündung / Bougie d'allumage pellet / Bujía encendido pellet
13	41801599550	Kit 50 candelette / 50 Sparkplugs kit / Bausatz 50 Zündkerzen / Kit 50 Bougies / Kit 50 Bujías
14	41200903900	Condotto candeletta / Sparkplug conduit / Zündkerzenkanal / Conduit bougie / Conducto bujía
15	41451303400	Trasduttore di pressione / Pressure transducer / Active-Wandler / Transducteur de pression / Transductor de pression
16	41451204900	Motoriduttore 3,3 RPM / Reduction motor 3,3 RPM / Getriebemotor 3,3 RPM / Motorréducteur 3,3 RPM / Motorreductor 3,3 RPM
17	4120398	Connettore motoriduttore-coclea / Reduction motor-feed screw connector / Verbindung Getriebemotor-Schnecke / Connecteur motorréducteur-vis sans fin / Conector motorreductor-cóclea
18	41401362750	Base della coclea / Feed screw base / Untergestell der Förderschnecke / Base de la vis sans fin / Base de la cóclea
19	41400903310	Flangia condotto coclea / Base of feed screw conduit / Untergestell Rohrleitung der Förderschnecke / Base du conduit de la vis sans fin / Base de conducto de la cóclea
20	4120615	Guarnizione base della coclea / Feed screw base gasket / Dichtung Untergestell der Förderschnecke / Joint pour la base de la vis sans fin / Junta base de la cóclea
21	41200901040	Coclea di caricamento pellet / Pellet feed screw / Pelletsförderschnecke / Vis sans fin pour chargement du pellet / Cóclea de carga pellet
23	41401077540V	Condotto della coclea / Conduit of feed screw / Rohrleitung der Förderschnecke / Conduit de la vis sans fin / Conducto de la cóclea
24	418008029	Guarnizione / Gasket / Dichtung / Joint / Junta
25	41451303600	Cavo connessione pannello / Control panel connection cable / Bedienblende Verbindungskabel / Cable de connection au tableau / Cable de conexión panel de comando
26	41451303706	Pannello comandi Hottoh 129 / Control panel Hottoh 129 / Bedienblende Hottoh 129 / Tableau de commande Hottoh 129 / Panel de mandos Hottoh 129
27	41450901100	Clickson 95°C / Clickson 95°C / Clickson 95°C / Clickson 95°C / Clickson 95°C
28	412007004	Clickson 110°C / Clickson 110°C / Clickson 110°C / Clickson 110°C / Clickson 110°C

TOBA HYDRO 22 HE

Componenti interni idraulici **SENZA** kit acqua sanitaria / Internal plumbing components **WITHOUT** domestic water kit / Interne hydraulische Bauteile **OHNE** Brauchwassersatz / Composants hydrauliques internes **SANS** kit eau sanitaire / Componentes internos hidráulicos **SIN** kit de agua sanitaria

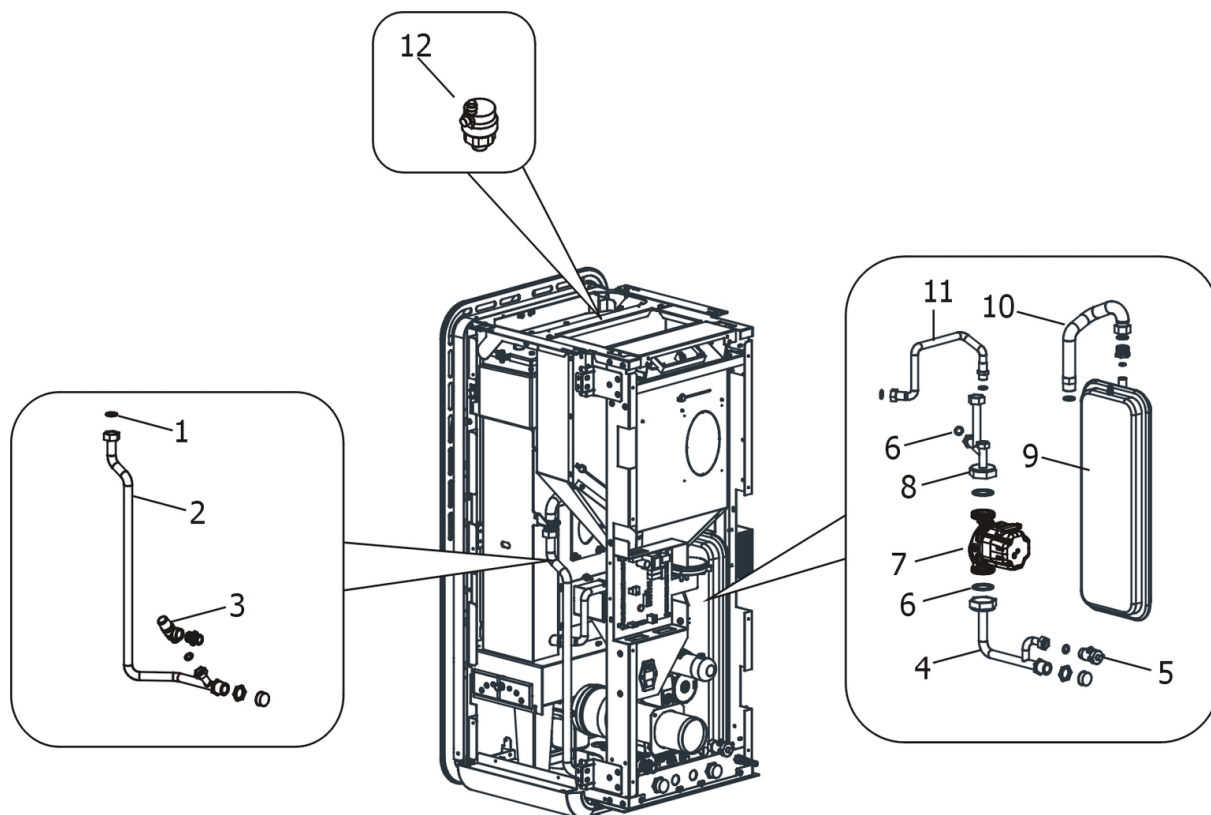

N°	Codice/Code	Descrizioni / Description / Beschreibung / Description / Descripción
1	41207910	Kit guarnizioni impianto idraulico / Hydraulic system gasket kit / Dichtungsbausatz für Hydraulikanlage / Kit de joints pour l'installation hydraulique / Kit de juntas de la instalación de fontanería
2	41501304100	Tubo mandata / Delivery tube / Vorlaufrohr / Tuyau refoulement / Tubo de envío
3	4120778	Valvola di massima pressione (3 bar) / Maximum pressure valve (3 bar) / Hochdruckventil (3 Bar) / Soupape de pression maximale (3 bar) / Válvula de máxima presión (3 bar)
4	41501303900	Tubo ritorno / Return tube / Rücklaufrohr / Tuyau retour / Tubo de regreso
5	4160351	Rubinetto scarico ½" con tappo / ½" drain valve with plug / Ablaufhahn ½" mit Stopfen / Robinet évacuation ½" avec bouchon / Grifo de desagüe ½" con tapón
6	41207910	Kit guarnizioni impianto idraulico / Hydraulic system gasket kit / Dichtungsbausatz für Hydraulikanlage / Kit de joints pour l'installation hydraulique / Kit de juntas de la instalación de fontanería
6	41207910	Kit guarnizioni impianto idraulico / Hydraulic system gasket kit / Dichtungsbausatz für Hydraulikanlage / Kit de joints pour l'installation hydraulique / Kit de juntas de la instalación de fontanería
7	41501500200	Pompa di circolazione acqua ALTA EFFICIENZA / Water circulation pump HE / Umwälzpumpe Hochleistung / Pompe de circulation eau HE / Bomba circulación agua alta eficiencia
8	41501304000	Tubo ritorno + vaso espansione / Return tube + expansion vessel / Rücklaufrohr + Expansionsgefäß / Tuyau retour + vase d'expansion / Tubo de regreso + vaso de expansión
9	4120775	Vaso espansione (6 l) / Expansion vessel (6 l) / Expansionsgefäß (6 l) / Vase d'expansion (6 l) / Vaso de expansión (6 l)
10	4120781	Giunto estensibile inox ¾" / ¾" stainless steel flexible joint / Edelstahl Verbindungsschlauch ¾" / Joint flexible inox ¾" / junta flexible inox ¾"
11	41500901300	Tubo flessibile inox 1/2" / 1/2" stainless steel flexible tube / Edelstahlschlauch 1/2" / Tuyau flexible inox 1/2" / Tubo flexible inox 1/2"
12	4120779	Valvola di sfiato / Vent valve / Entlüftungsventil / Soupape de dégagement / Válvula respiradero

TOBA HYDRO 22 HE

Gruppo scambiatore / Exchanger group / Austausch Baugruppe / Groupe échangeur / Grupo intercambiador

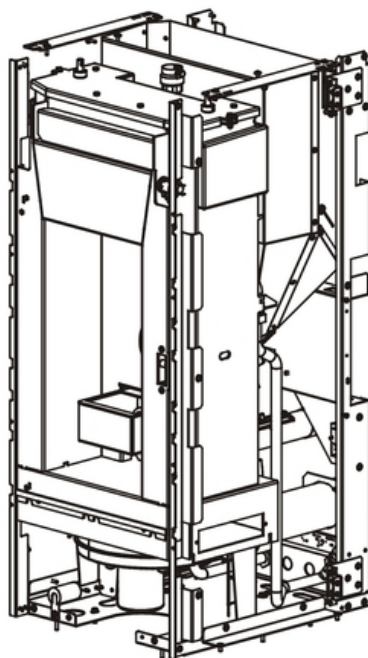
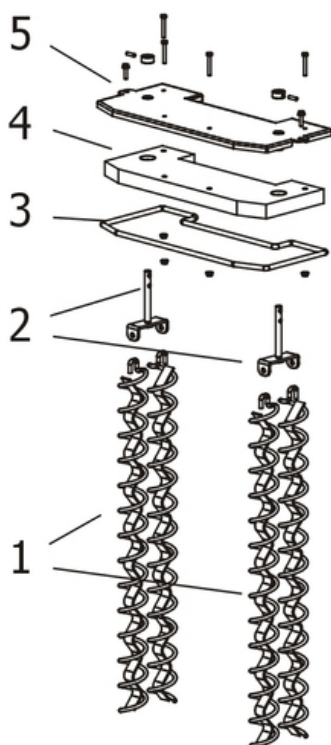

N°	Codice/Code	Descrizioni / Description / Beschreibung / Description / Description
1	41400914540	Eliche raschiatore (1 pz.) / Turbulator props (1 pc.) / Propeller des Schabers (1 Teil) / Hélices turbulateur (1 pz.) / Héliche rascador (1 pz.)

2	41400914740	Staffa sostegno raschiatore / Turbulator support bar / Haltebügel der Reinigungsspirale / étrier support turbulateur / Zuncho apoyo rascador
3	41201031	Kit sostituzione cordino (cordino+silicone) Ø 10 mm / Cord replacement kit (cord + silicon) Ø 10 mm / Schnuraustauschsatz (Schnur+Silikon) Ø 10 mm / Kit remplacement cordon (cordon + silicone) Ø 10 mm / Kit sustitución junta a cuerda (junta a cuerda+silicón) Ø 10 mm
3	4120103A	Cordino fibroceramico Ø 10 mm (5 mt.) / Ceramic fibre cord Ø 10 mm (5 m) / Keramikfaserschnur Ø 10 mm (5 m) / Cordon en fibre céramique Ø 10 mm (5 m) / Junta a cuerda de fibra cerámica Ø 10 mm (5 m)
3	4120103B	Cordino fibroceramico Ø 10 mm (50 mt.) / Ceramic fibre cord Ø 10 mm (50 m) / Keramikfaserschnur Ø 10 mm (50 m) / Cordon en fibre céramique Ø 10 mm (50 m) / Junta a cuerda de fibra cerámica Ø 10 mm (50 m)
4	41150900100	Pannello calorite coperchio caldaia / Boiler cover calorite panel / Kesseldeckepaneel aus Calorite / Panneau en calorite couvercle chaudière / Panel en calorite tapa caldera
5	41400914840V	Coperchio scambiatore / Exchanger cover / Deckel des Austauschers / Couvercle Echangeur / Tapa intercambiador