

WALL AIR 8/8 UP! M1

Gruppo estetico / Aesthetic group / Aesthetische Gruppe / Groupe esthétique / Grupo estético

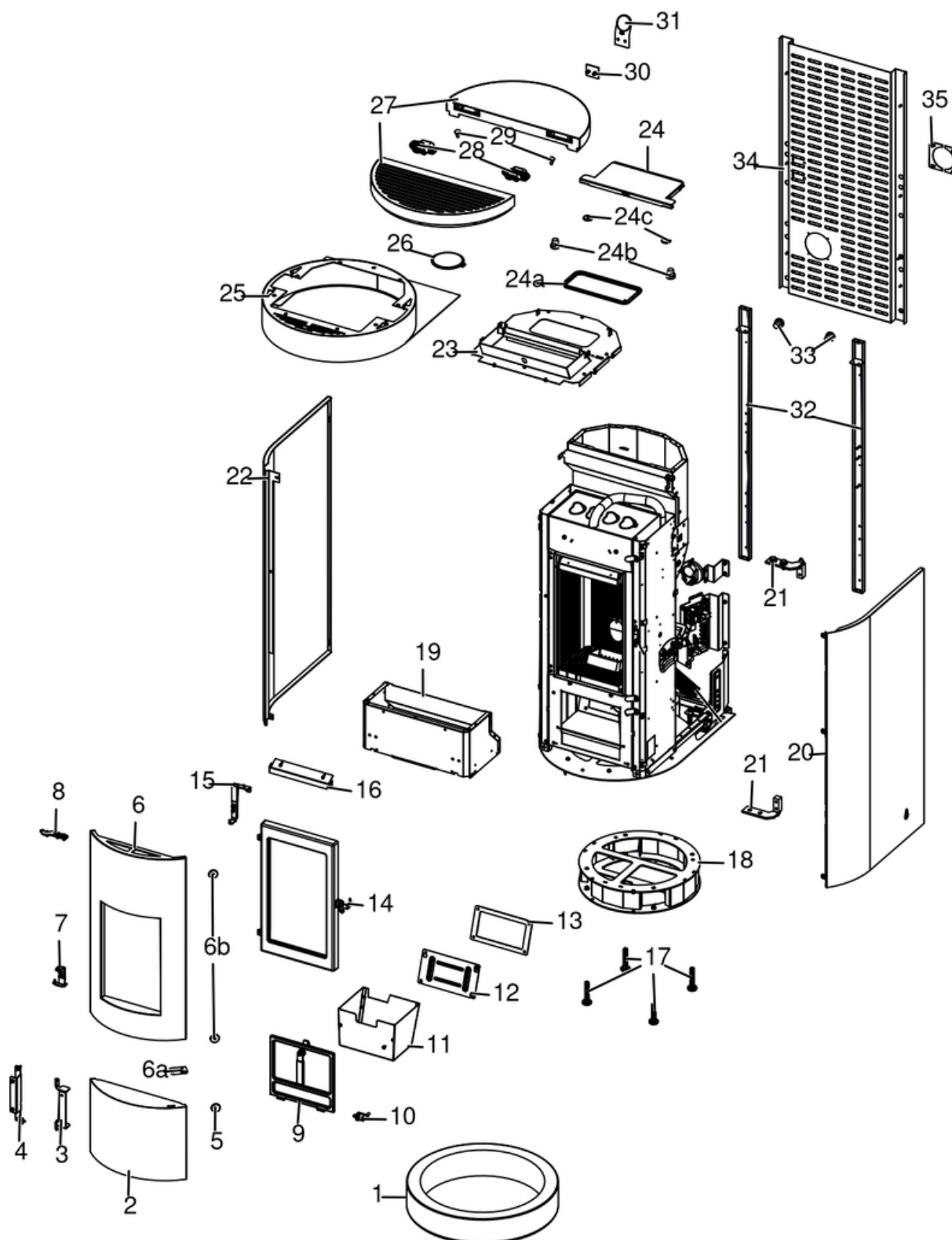

N°	Codice/Code	Descrizioni / Description / Beschreibung / Description / Description
1	6919018	Rivestimento Black / Black cladding / Verkleidung Black / Habillage Black / Revestimiento Black
1	6919019	Rivestimento Beton / Beton cladding / Verkleidung Beton / Habillage Beton / Revestimiento Beton

1	6919020	Rivestimento Stone / Stone cladding / Verkleidung Stone / Habillage Stone / Revestimiento Stone
1	6919021	Rivestimento Terrazzo / Terrazzo cladding / Verkleidung Terrazzo / Habillage Terrazzo / Revestimiento Terrazzo
1	6919022	Rivestimento Wood / Wood cladding / Verkleidung Wood / Habillage Wood / Revestimiento Wood
2	4141163304000	Frontale inferiore / Lower front / Unterer Front / Frontal inférieur / Frontal inferior
3	41411633630P	Cerniera frontale inferiore / Front lower hinge / Vordere untere Scharnier / Charnière frontale inférieure / Bisagra frontal inferior
4	41411628440V	Cerniera inferiore nera / Black lower hinge / Schwarzes unteres Scharnier / Charnière inférieure noire / Bisagra inferior negra
5	41801657900	Magneti (pz.2) / Magnet (pcs.2) / Magnet (stk. 2) / Aimant (pcs.2) / Imán (pz.2)
6	437019084	Porta estetica / Aesthetic door / Außentür / Porte esthétique / Puerta estética
6a	41411700160	Maniglia porta estetica / External door handle / Außentür Griff / Poignée porte extérieure / Tirador puerta exterior
6b	41801657900	Magneti (pz.2) / Magnet (pcs.2) / Magnet (stk. 2) / Aimant (pcs.2) / Imán (pz.2)
7	4141191284000	Cerniera inferiore / Lower hinge / Unterer Scharnier / Charnière inférieur / Bisagra inferior
8	4141191304000	Cerniera superiore / Upper hinge / Oberer Scharnier / Charnière supérieur / Bisagra superior
9	437016130	Porta cenere con maniglia / Ash drawer door with handle / Tür des Aschenkastens mit Griff / Porte tiroir à cendres avec poignée / Puerta cajón ceniza con tirador
10	41411623740V	Cerniera acciaio porta cenere / Ash compartment door steel hinge / Aschenklappe Stahlscharnier / Charnier en acier porte compartiment cendre / Bisagra en acero puerta compartimento cenizas
11	437016041	Cassetto cenere / Ash drawer / Aschenkasten / Tiroir à cendres / Cajón ceniza
12	41401339610	Tappo ispezione vano fumi / Smoke compartment inspection plug / Inspektionsdeckel Rauchabzug / Clapet inspection compartiment fumées / Tapón inspección compartimento humos
13	41800900600	Guarnizione / Gasket / Dichtung / Joint / Junta
14	437017082	Porta fuoco in ghisa / Cast iron fireplace door / Feuertür aus Gusseisen / Porte foyer en fonte / Puerta hogar de arrabio
15	4141191224000	Cerniera superiore / Upper hinge / Oberer Scharnier / Charnière supérieur / Bisagra superior
16	41411615430V	Deflettore aria / Air deflector / Luftleitblech / Déflecteur aire / Deflector aire
17	41200906660	Piedini di appoggio (4 pz.) / Support feet (4 pcs.) / Einstellfüße (4 Stck.) / Vérins d'appui (4 p.es) / Pies de apoyo (4 piezas)
18	437019083	Basamento / Base / Basis / Base / Basamento
19	41411624150	Convogliatore aria / Air conveyor / Luftblech / Convoyeur air / Conductor del aire
20	4141191104100	Fianco sinistro / Left side / Linke Seite / Coté gauche / Lateral izquierdo
21	4141190851000	Cerniera fianco / Side hinge / Seitenscharnier / Charnière coté / Bisagra lateral
22	4141191064000	Fianco destro / Right side / Rechte Seite / Coté droite / Lateral derecho
23	4141191244000	Supporto top / Top support / Halterung Abdeckplatte / Support dessus / Soporte top
24	437016053	Coperchio serbatoio / Hopper cover / Deckel Pelletbehälter / Couvercle réservoir / Tapa depósito
24a	41801601400	Guarnizione coperchio serbatoio / Pellet hopper cover gasket / Deckel Pelletbehälter Dichtung / Joint couvercle réservoir pellet / Junta tapa depósito pellet
24b	4120180	Gommini paracolpi (4 pz) / Rubber bumpers (4 pcs.) / Schlagschutzgummi (4 Stck) / Pièces caoutchouc antichoc (4 pcs) / Cauchitos anti-golpes (4 pz)
24c	41801657900	Magneti (pz.2) / Magnet (pcs.2) / Magnet (stk. 2) / Aimant (pcs.2) / Imán (pz.2)
25	4141190934000	Cintura superiore / Upper belt / Oberer Gürtel / Ceinture supérieur / Cinturón superior
26	4141191144000	Tappo fumi / Smoke plug / Rauchgasklappe / Clapet fumées / Tapón humos
27	41411927650	Top con coperchio / Top with cover / Abdeckplatte mit Deckel / Dessus avec couvercle / Top con tapa
28	41201900900	Cerniere invisibili (2 pz) / Invisible hinges (2pcs) / Unsichtbare Scharniere (2 Stk) / Charnières invisibles (2 pcs) / Bisagras invisibles (2 pzs)
29	41801002300	Paracolpi in silicone Ø 8/5 (2pz) / Silicone bumpers Ø 8/5 (2pcs) / Schlagschutzgummi Ø 8/5 (2 Stck) / Pièces silicone antichoc Ø 8/5 (2pcs) / Anti-golpes en silicona Ø 8/5 (2pzs)
30	4141191794000	Placca fissaggio maniglia / Handle fixing plate / Befestigungsplatte für Griff / Plaque fixation poignée / Placa de fijación manija
31	41801902100	Maniglia in gomma / Gum handle / Gummigriff / Poignée en gomme / Mango de goma
32	4141190864000	Montante posteriore / Rear rod / Hintere Montageleiste / Montant postérieur / Montante posterior
33	4120180	Gommini paracolpi (4 pz) / Rubber bumpers (4 pcs.) / Schlagschutzgummi (4 Stck) / Pièces caoutchouc antichoc (4 pcs) / Cauchitos anti-golpes (4 pz)
34	4141190923000	Schiena / Rear back / Rückwand / Dos / Espalda
35	41401907410	Supporto tubo fumi / Smoke pipe suport / Rauchrohr Halterung / Support tuyau fumées / Soporte tubo humos

WALL AIR 8/8 UP! M1

Porta fuoco / Fire door / Feuertür / Porte foyer / Puerta hogar

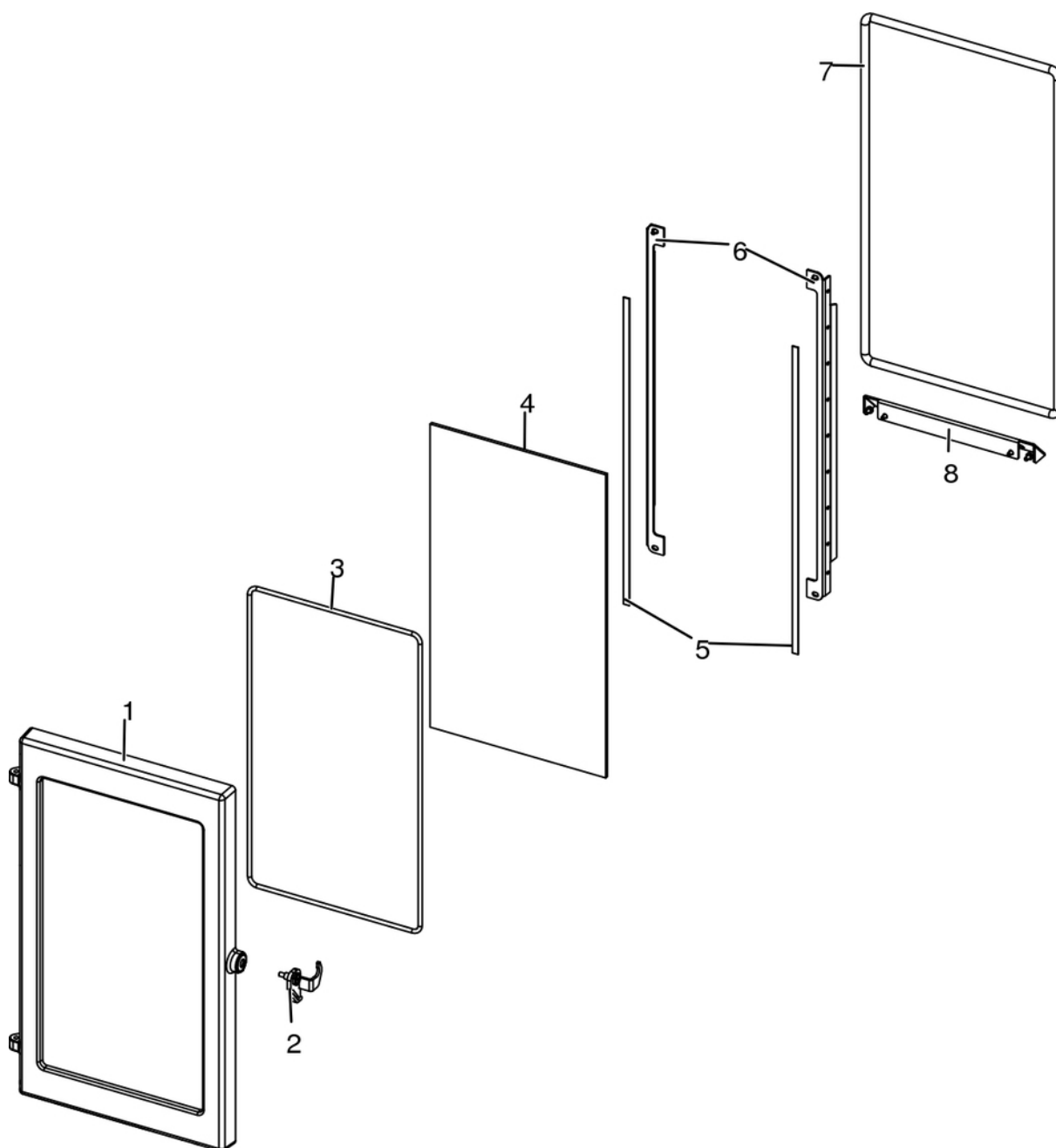

N°	Codice/Code	Descrizioni / Description / Beschreibung / Description / Description
1	41301602500V	Telaio porta fuoco / Fire door frame / Feuertürrahmen / Cadre foyer / Armazón puerta de arrabio
2	41411616560	Maniglia porta nera / Door Handle / Türgriff / Poignée porte / Tirador
3	41801603300A	Guarnizione Ø5 5mt / Gasket Ø5 5mt / Dichtung Ø5 5mt / Joint Ø5 5mt / Junta Ø5 5mt
3	41801603300B	Guarnizione Ø5 50mt / Gasket Ø5 50mt / Dichtung Ø5 50mt / Joint Ø5 50mt / Junta Ø5 50mt
3	41801603300C	Guarnizione Ø5 5mt + silicone / Gasket Ø5 5mt + silic / Dichtung Ø5 5mt + Silikon / Joint Ø5 5mt + silic / Junta Ø5 5mt
4	41701600300	Vetroceramico porta ghisa / Cast iron door glass / Glaskeramikscheibe Tür aus Gusseise / Vitrocéremique porte en fonte / Cristal cerámico puerta en arrabio
5	4120573A	Guarnizione a nastro 8 mm (5 mt.) per porta / Door strip gasket 8 mm (5 m) / Türbanddichtung 8 mm (5 m) / Joint ruban 8 mm (5 m) pour porte / Guarnición de cinta para puerta 8 mm (5 m)
5	4120573B	Guarnizione a nastro 8 mm (50 mt.) per porta / Door strip gasket 8 mm (50 m) / Türbanddichtung 8 mm (50 m) / Joint ruban 8 mm (50 m) pour porte / Guarnición de cinta para puerta 8 mm (50 m)

6	41411622030V	Profilo fermavetro / Fastening bracket profile / Haltebügel für Scheibebefestigung Profil / Profil patte de fixation / Perfil fermacristal
7	4120104A	Cordino fibroceramico Ø 12 mm (5 mt.) / Ceramic fibre cord Ø 12 mm (5 m.) / Keramikfaserschnur Ø 12 mm (5 m) / Cordon en fibre céramique Ø 12 mm (5 m) / Junta a cuerda de fibra cerámica Ø 12 mm (5 m)
7	4120104B	Cordino fibroceramico Ø 12 mm (50 mt.) / Ceramic fibre cord Ø 12 mm (50 m.) / Keramikfaserschnur Ø 12 mm (50 m) / Cordon en fibre céramique Ø 12 mm (50 m) / Junta a cuerda de fibra cerámica Ø 10 mm (52 m)
7	41201041	Kit sostituzione cordino (cordino+silicone) Ø 12 mm / Cord replacement kit (cord + silicon) Ø 12 mm / Schnuraustauschsatz (Schnur+Silikon) Ø 12 mm / Kit remplacement cordon (cordon + silicone) Ø 12 mm / Kit sustitución junta a cuerda (junta a cuerda+silicón) Ø 12 mm
8	41411622130V	Scivolo cenere / Ash ramp / Aschenrutsche / Glissière cendre / Tobogán ceniza

WALL AIR 8/8 UP! M1

Gruppo camera di combustione / Combustion chamber group / Verbrennungskammer Gruppe / Group de chambre de combustion / Grupo cámara de combustión

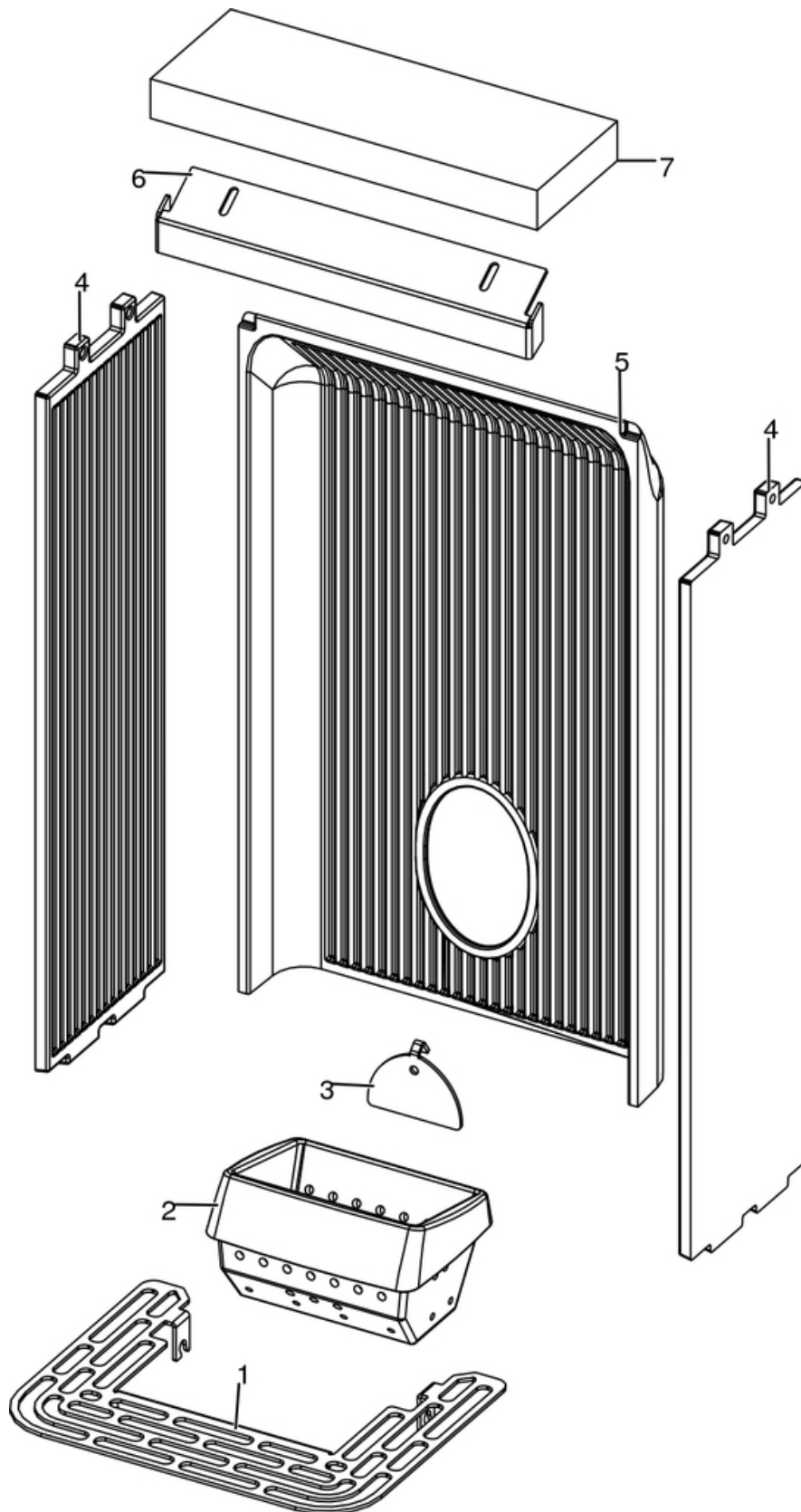

N°	Codice/Code	Descrizioni / Description / Beschreibung / Description / Descripcion
1	41411634830V	Griglia focolare / Fire Box Grille / Feuerstellenrost / Grille Foyer / Rejilla Hogar
2	41301502400V	Braciare ghisa / Cast iron grate / Brennertopf aus Gusseisen / Brasero en fonte / Brasero en arrabio
3	41411613530V	Deflettore pellet / Pellet deflector / Pellet Leitblech / Deflecteur pellet / Deflector pellet
4	41301502500V	Fianco ghisa / Cast iron side / Seite aus Guß / Côté en fonte / Placa lateral de arrabio
5	41301502600V	Schiena ghisa / Cast iron back / Rückwand aus Gusseisen / Dossieret en fonte / Parte trasera en arrabio
6	41411615430V	Deflettore aria / Air deflector / Luftleitblech / Déflecteur aire / Deflector aire
7	41151600200	Deflettore focolare in vermiculite / Vermiculite deflector / Leitblech aus Vermiculite / Déflecteur en vermiculite / Deflector en vermiculite

WALL AIR 8/8 UP! M1

Porta cenere / Ash door / Ashentür / Porte cendre / Puerta ceniza

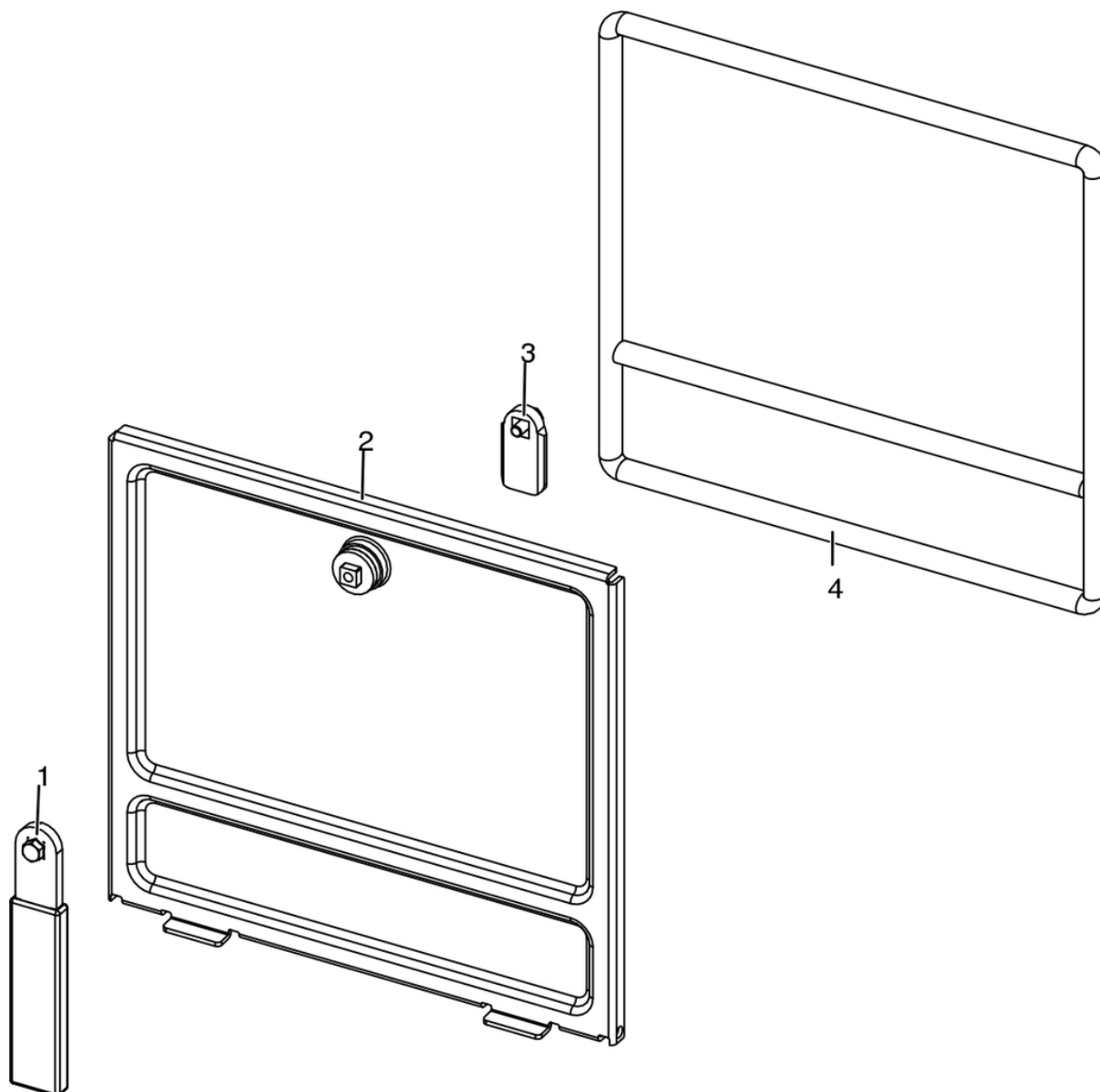

N°	Codice/Code	Descrizioni / Description / Beschreibung / Description / Descripción
1	41411621600	Maniglia con impugnatura porta cenere / Handle / Griff / Poignée / Tirador
2	41421602141V	Porta cenere / Ash drawer door / Tür des Aschenkastens / Porte tiroir à cendres / Puerta cajón ceniza
3	41201608400	Serratura porta cassetto cenere / Door lock for ash drawer / Türschloss für Aschenkasten / Serrure de porte du tiroir à cendres / Cerradura puerta cajón ceniza
4	412007003A	Cordino fibroceramico Ø 14 mm (5 mt.) / Ceramic fibre cord Ø 14 mm (5 m.) / Keramikfaserschnur Ø 14 mm (5 m) / Cordon en fibre céramique Ø 14 mm (5 m) / Junta a cuerda de fibra cerámica Ø 14 mm (5 m)
4	412007003B	Cordino fibroceramico Ø 14 mm (50 mt.) / Ceramic fibre cord Ø 14 mm (50 m.) / Keramikfaserschnur Ø 14 mm (50 m) / Cordon en fibre céramique Ø 14 mm (50 m) / Junta a cuerda de fibra cerámica Ø 14 mm (50 m)
4	412007003C	Kit sostituzione cordino (cordino+silicone) Ø 14 mm / Cord replacement kit (cord + silicon) Ø14 mm / Schnuraustauschsatz (Schnur +Silikon) Ø 14 mm / Kit remplacement cordon (cordon+silicon) Ø 14 / Kit sustitución junta a cuerda (junta a cuerda+silicón) Ø 14 mm

WALL AIR 8/8 UP! M1

Gruppo caricamento pellet / Pellet feed group / Pellet Fördergruppe / Groupe chargement du pellet / Grupo de carga pellet

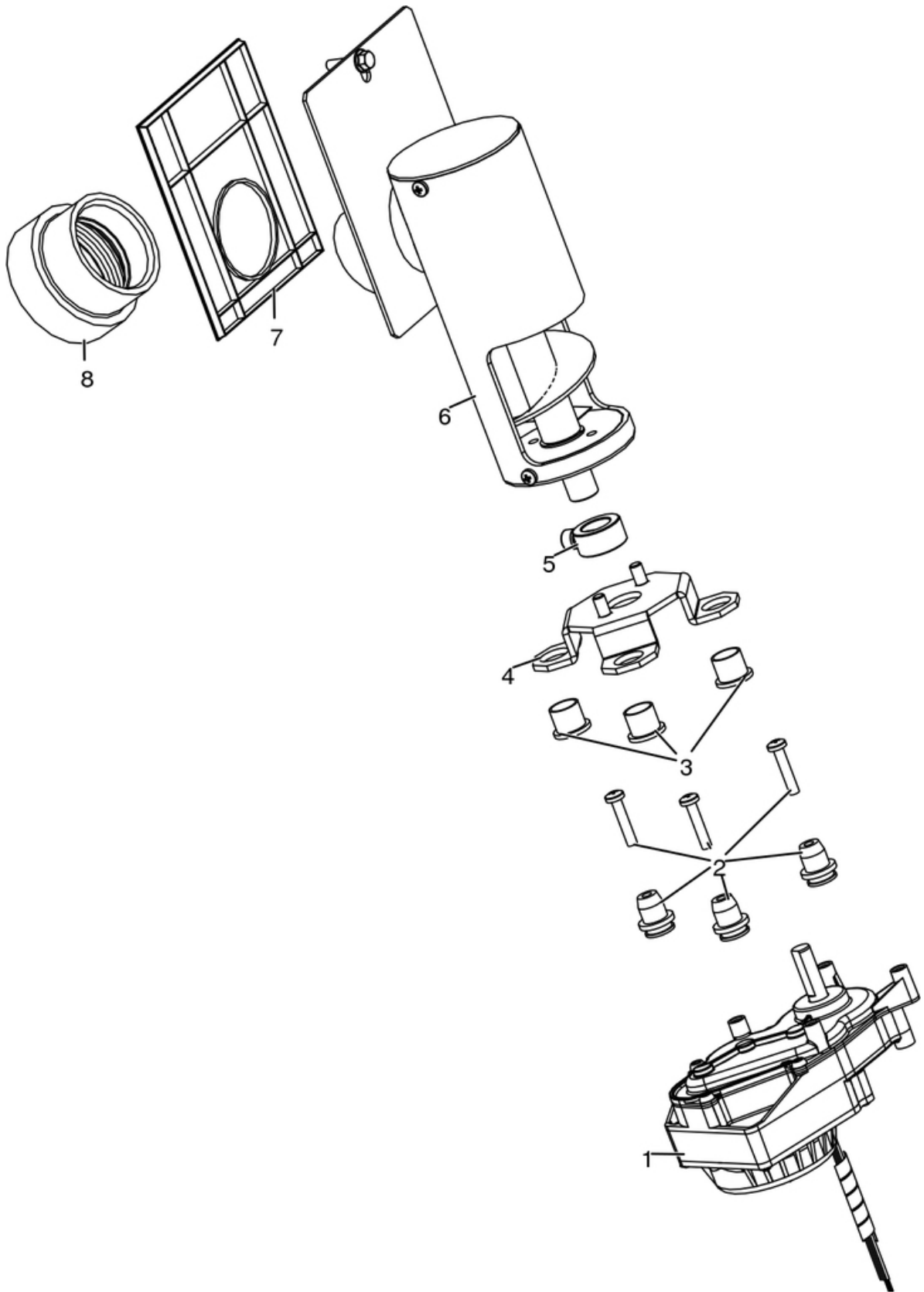

N°	Codice/Code	Descrizioni / Description / Beschreibung / Description / Descripción
1	41451702200	Motoriduttore brushless / Brushless reduction motor / Brushless Getriebemotor / Motoréducteur brushless / Motorreductor brushless
2	41801703700	Gommini antivibrante / Vibration damper rubber / Rammschutz Gummi / Caoutchouc antivibratoire / Cauchitos antivibración
3	41201800700	Boccola (3 pz) / Bushing (3 pcs) / Buchse (3 Stk) / Douille (3 pcs) / Abrazadera (3 pzs)
4	41411779331	Supporto coclea "Ragno" / Pellet feed screw bracket "spider" / "Spinne" Schenke Gestell / Support vis sans fin "Araignée" / Soporte coclea "Araña"
5	4120398	Connettore motoriduttore-coclea / Reduction motor-feed screw connector / Verbindung Getriebemotor-Schnecke / Connecteur motoréducteur-vis sans fin / Conector motorreductor-cóclea
6	41411800151	Gruppo alimentazione completo / Complete feed screw / Komplette Förderschnecke / Vis sans fin complète / Coclea de carga completa
7	41801600400	Guarnizione gruppo caricamento / Gasket / Dichtung / Joint / Junta
8	41801702600	Disaccoppiatore mesc. Marrone / Brown disengaging device / Braun Verängungsrohr / Tuyau de découplage maron / Tubo de desvío marron

WALL AIR 8/8 UP! M1

Gruppo accensione / Ignition group / Entzündung Gruppe / Groupe d'allumage / Grupo ignición

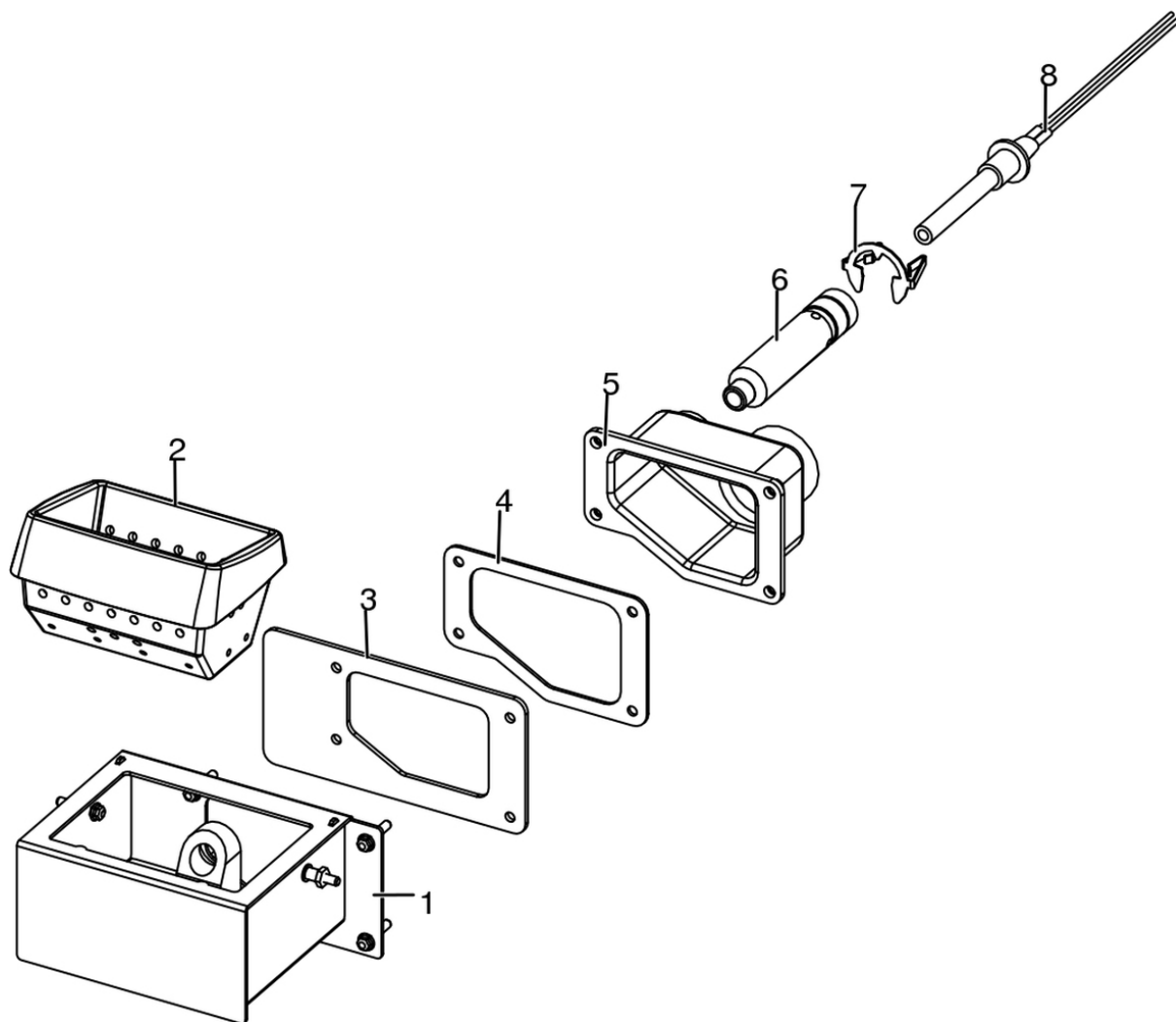

N°	Codice/Code	Descrizioni / Description / Beschreibung / Description / Descripción
1	41411613140V	Tasca braciere / Combustion pot container / Brenntopfkasten / Réciipient brasero / Contenedor brasero
2	41301502400V	Braciere ghisa / Cast iron grate / Brenntopf aus Gusseisen / Brasero en fonte / Brasero en arrabio
3	41801601500	Guarnizione tasca braciere / Combustion pot container gasket / Brenntopfkasten Dichtung / Joint réciipient brasero / Junta contenedor brasero
4	41801602300	Guarnizionaio codolo / Gasket / Dichtung / Joint / Junta
5	41311600100	Codolo / Tool chuck / Einspannschaft / Outil d'emmanchement / Mango
6	41601601000	Condotto candeletta / Sparkplug Conduit / Zündkerzenkanal / Conduit Bougie / Conducto Bujía
7	41201601500	Anello arresto candeletta / Sparkplug stop / Zündkerzestopper / Butée bougie / Tope bujía
8	41451308101	Candeletta 315 Watt / Sparkplug 315 Watt / Zündkerze 315 Watt / Bougie 315 Watt / Bujía 315 Watt
8	41451308150	Kit 25 candelette 315 Watt / 25 Sparkplugs 315 Watt kit / Bausatz 25 Zündkerzen 315 Watt / Kit 25 Bougies 315 Watt / Kit 25 Bujías 315 Watt

WALL AIR 8/8 UP! M1

Gruppo elettrico ed elettronico / Electrical and electronic group / Elektrische und elektronische Gruppe / Groupe électrique et électronique / Grupo eléctrico y electrónico

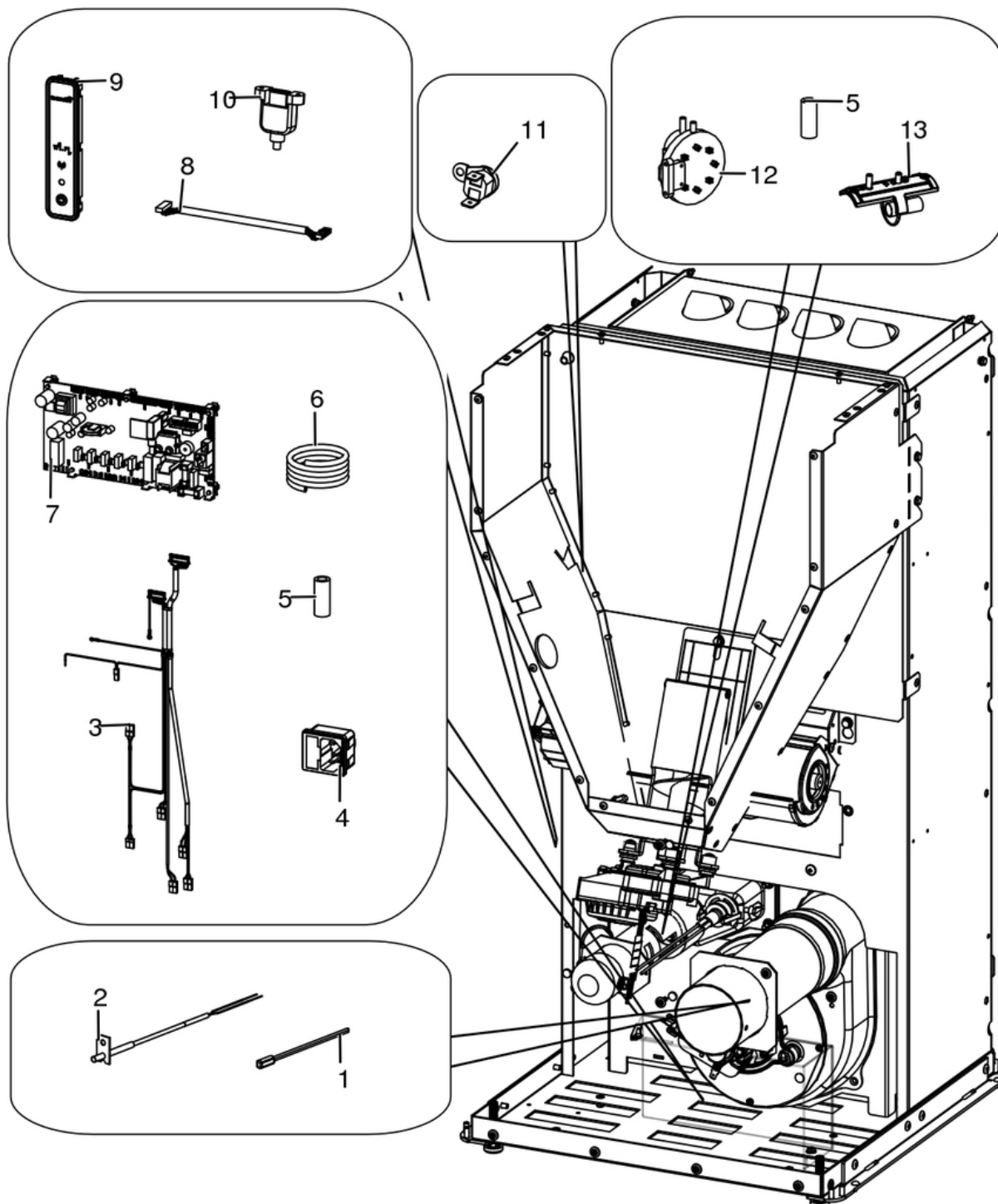

N°	Codice/Code	Descrizioni / Description / Beschreibung / Description / Description
1	4160386	Sonda temperatura ambiente/acqua / Room/Water temperature sensor / Raum- Wassertemperaturfühler / Sonde température ambiance/eau / Sonda temperatura ambiente/agua
2	41451703600	Sonda fumi con flangia con morsetti L.980 / Smoke sensor with flange with terminal board L.980 / Rauchsonde mit Flansche mit Klemmenbrett L.980 / Sonde fumées avec bride avec serre-câble L.980 / Sonda humos con brida con borne L.980
3	41451904700	Cablaggio elettrico Maestro / Maestro electrical wiring / Elektrische Verkabelung Maestro / Câblage électrique Maestro / Cableado eléctrico Maestro

3	41452000500	Cavo motoriduttore / Reduction motor cable / Kabel Getriebemotor / Câble motoréducteur / Cable motorreductor
4	41451104100	Presca con fusibile / Socket with fuse / Steckdose mit Sicherung / Prise avec fusible / Toma con fusible
5	4120631A	Tubicino silicónico - 5m / Silicon tube - 5m / Silikonrohr - 5m / Petit tuyau en silicone - 5m / Tubo silicónico - 5m
6	41801902500A	Spirale Rilsan (5 spire) / Rilsan spiral (5 coils) / Spirale Rilsan (5 Windungen) / Spirale Rilsan (5 spires) / Espiral Rilsan (5 espire)
6	41801902500	Spirale Rilsan (30 m.) / Rilsan spiral (30 m.) / Spirale Rilsan (30 M.) / Spirale Rilsan (30 m.) / Espiral Rilsan (30 m.)
7	41451904300	Scheda madre / Motherboard / Hauptplatine / Carte mère / Tarjeta madre
7	41451904300A	Sensirion / Sensirion / Sensirion / Sensirion / Sensirion
8	41451801600	Cavo flat 20 vie L.600 mm / Flat cable 20 pin L.600 mm / Flat-Kabel 20polig L.600 mm / Cable flat 20 voies L.600 mm / Flat cable 20 vias L.600 mm
9	41451602802	Pannello di emergenza Wireless / Wireless emergency display / Wireless Notfall-Blende / Panneau d'urgence wireless / Panel emergencia wireless
10	41451403200	Cavo USB da pannello L.500 / USB Cable from display L.500 / USB Kabel von Notfalldisplay L.500 / Câble USB de panneau L.500 / Cable USB del panel L.500
11	412007004	Clickson 110°C / Clickson 110°C / Clickson 110°C / Clickson 110°C / Clickson 110°C
12	41451003700	Pressostato / Pressure switch / Druckschalter / Pressostat / Presostato
13	41601301850	Componente rilevamento portata aria / Air flow measure component / Bauteil für Messung der Luftmenge / Composent pour la mesuration de la quantité d'air / Componente por la medida de l'aire

WALL AIR 8/8 UP! M1

Gruppo aria comburente / Combustion air group / Verbrennungsluft Gruppe / Groupe air comburant / Grupo aire comburente

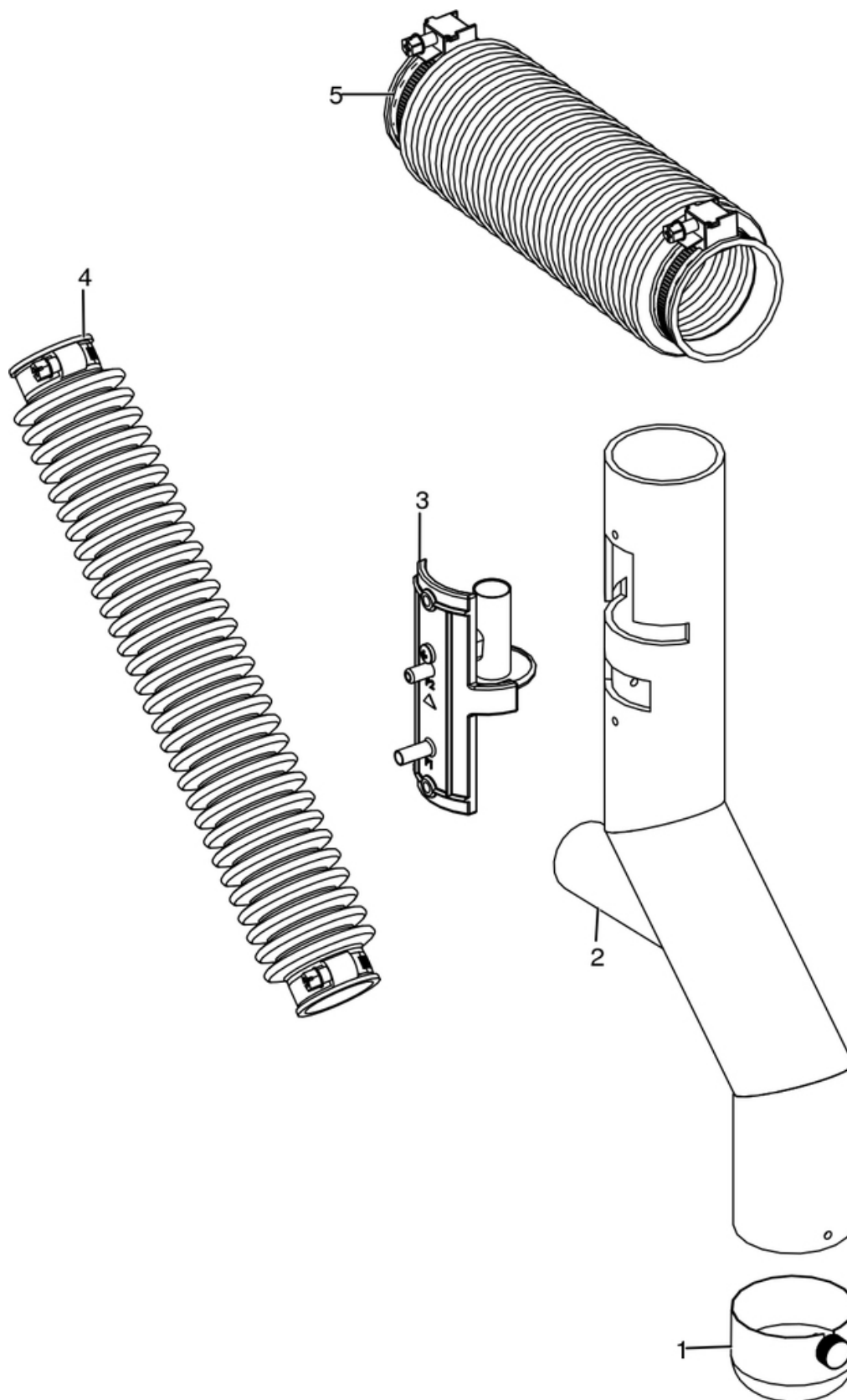

N°	Codice/Code	Descrizioni / Description / Beschreibung / Description / Descripcion
1	41401036100	Filtro antipolvere / Anti-dust filter / Staubschutzfilter / Filtre antipoussière / Filtro de protección polvo
2	4160190054000	Tubo aspirazione / Aspiration pipe / Absaugen Rohr / Tuyau aspiration / Tubo aspiración
3	41601301850	Componente rilevamento portata aria / Air flow measure component / Bauteil für Messung der Luftmenge / Composent pour la mesuration de la quantité d'air / Componente por la medida de l'aire
4	41801601900	Tubo aspirazione pulizia vetro / Inlet pipe for cleaning glass air / Glassreinigungs Lufteingangsrohr / Tuyau entrée pour l'aire de nettoyage du vitre / Tubo entrada por l'aire de limpieza vidrio
5	41801601700	Tubo aspirazione camera combustione / Combustion chamber aspiration tube / Verbrennungskammer Förderrohr / Tuyau aspiration air chambre de combustion / Tubo aspiración aire cámara de combustión

WALL AIR 8/8 UP! M1

Gruppo ventilazione / Ventilation group / Lüftungsgruppe / Groupe de ventilation / Grupo de ventilación

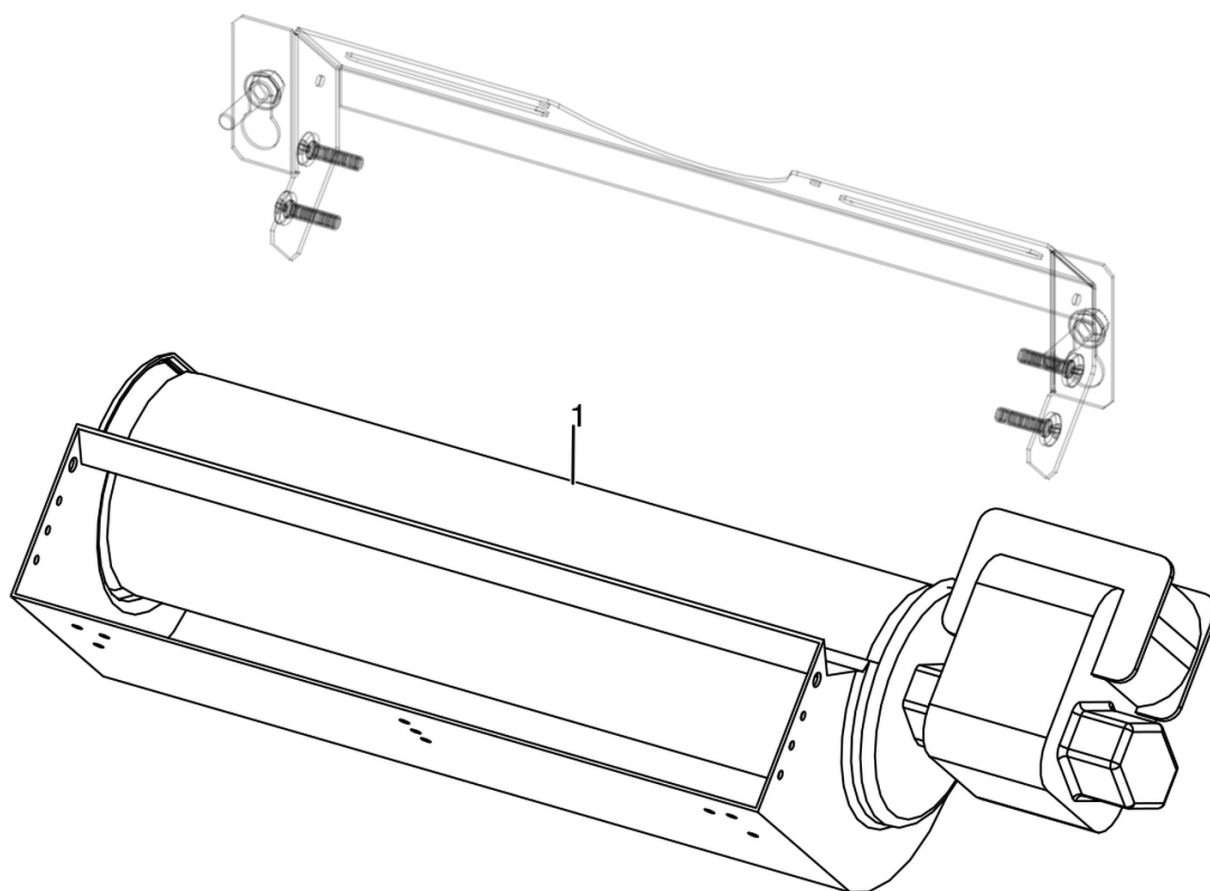

N°	Codice/Code	Descrizioni / Description / Beschreibung / Description / Descripción
1	41451600800	Ventilatore aria / Air fan / Luftgebläse / Ventilateur air / Ventilador aire

WALL AIR 8/8 UP! M1

Gruppo fumi UP! / UP! Smoke group / UP! Rauchgruppe / Groupe fumées UP! / Grupo de humos UP!

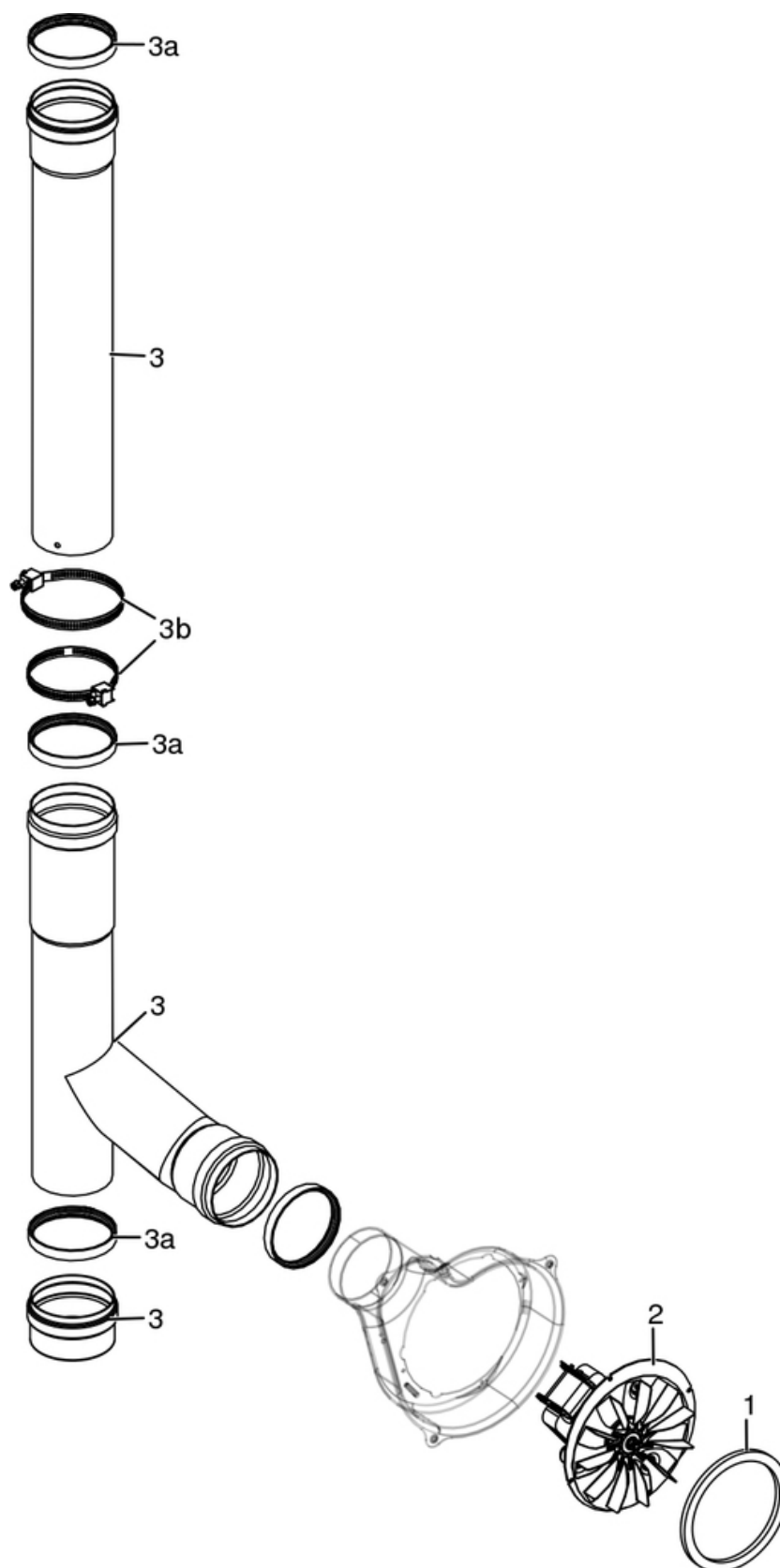

N°	Codice/Code	Descrizioni / Description / Beschreibung / Description / Descripción
1	41801600800	Guarnizione ventilatore fumi / Smoke exhaust fan gasket / Dichtung Rauchabsauggebläse / Joint Ventilateur aspiration fumées / Junta ventilador aspiración humos
2	41451503200	Ventilatore fumi stagno / Air-tight smoke exhausted fan / Luftdichtes Rauchgasgebläse / Ventilateur fumées étanche / Ventilador humos hermético
2	41451703000	Encoder per ventilatore fumi marchio EBM / Encoder for EMB smoke fan / Encoder für EBM Rauchgasgebläse / Encoder pour ventilateur des fumées marque EBM / Encoder para ventilador humos marca EBM
2	41451209300	Encoder per ventilatore fumi marchi LN2/SIT / Encoder for LN2/SIT smoke fan / Encoder für LN2/SIT Rauchgasgebläse / Encoder pour ventilateur des fumées marques LN2/SIT / Encoder para ventilador humos marcas LN2/SIT
2	41452009200	Encoder ventilatore / Fan encoder / Lüfter Encoder / Encodeur de ventilateur / Codificador de ventilador
3	4019009	Kit uscita fumi Up / Smoke outlet kit Up / Rauchabzugskit Up / Kit sortie de fumées Up / Kit salida humos Up
3a	40120969	Guarnizione silicone (5pz) / Silicone Gasket (5pc.) / Silikondichtung (5 St.) / Joint en silicone / Junta en silicona
3b	4008043	Fascette Ø 60-170 mm / Clamps Ø 60-170 mm / Rohrschellen Ø 60-170 mm / Colliers Ø 60-170 mm / Bandas Ø 60-170 mm
3b	4011009	Kit fascette (4 pz) / Kit clamps (4 pcs) / Rohrschellen (4 Stk) / Kit collier (4 pcs) / Kit de bandas (4 pzs)

WALL AIR 8/8 UP! M1

Gruppo fumi / Smoke group / Rauchgruppe / Groupe fumées / Grupo de humos

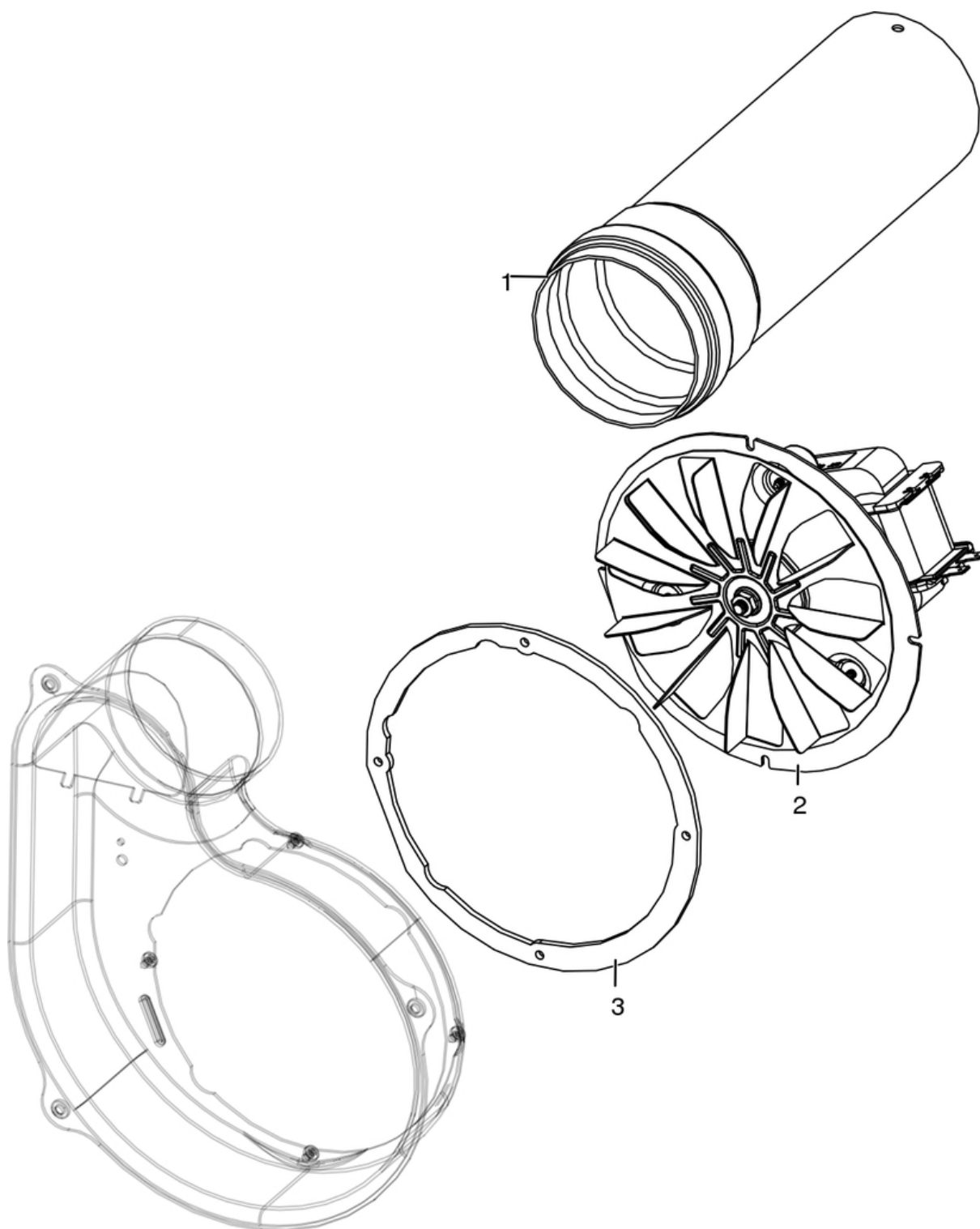

N°	Codice/Code	Descrizioni / Description / Beschreibung / Description / Descripcion
1	41601604560	Tubo fumi Ø 80 con guarnizione / Smoke pipe Ø 80 with gasket / Rauchrohr Ø 80 mit Dichtung / Tuyau fumées Ø 80 avec joint / Tubo humos Ø 80 con junta
2	41451503200	Ventilatore fumi stagno / Air-tight smoke exhausted fan / Luftdichtes Rauchgasgebläse / Ventilateur fumées étanche / Ventilador humos hermético
2	41451209300	Encoder per ventilatore fumi marchi LN2/SIT / Encoder for LN2/SIT smoke fan / Encoder für LN2/SIT

		Rauchgasgebläse / Encoder pour ventilateur des fumées marques LN2/SIT / Encoder para ventilador humos marcas LN2/SIT
2	41451703000	Encoder per ventilatore fumi marchio EBM / Encoder for EMB smoke fan / Encoder für EBM Rauchgasgebläse / Encoder pour ventilateur des fumées marque EBM / Encoder para ventilador humos marca EBM
2	41452009200	Encoder ventilatore / Fan encoder / Lüfter Encoder / Encodeur de ventilateur / Codificador de ventilador
3	41801600800	Guarnizione ventilatore fumi / Smoke exhaust fan gasket / Dichtung Rauchabsauggebläse / Joint Ventilateur aspiration fumées / Junta ventilador aspiración humos