

N°	Codice/Code	Descrizioni / Description / Beschreibung / Description / Descripcion
1	41402033850	Porta completa / Complete door / Komplette Tür / Porte complète / Puerta completa
2	41201501700	Cerniera Pz.2 / Hinge Pcs.2 / Scharnier Stk.2 / Charnière Pcs.2 / Bisagra Pz.2
3	412008063	Cerniere porta fuoco (2 pz) / Fire door hinge (2pcs) / Scharnier Feuertür (2 Stck) / Charnière porte foyer (2 pcs) / bisagra puerta del hogar (2 pz)
4	41411647250	Porta cenere completo / Ash drawer door / Tür des Aschenkastens / Porte tiroir à cendres / Puerta cajón ceniza
5	41401819130	Staffa sicurezza porta cenere / Ash holder safety bracket / Aschentür Sicherheitsbügel / Support de sécurité pour porte-cendres / Soporte de seguridad porta cenizas
6	41801002300	Paracolpi in silicone Ø 8/5 (2pz) / Silicone bumpers Ø 8/5 (2pcs) / Schlagschutzgummi Ø 8/5 (2 Stck) / Pièces silicone antichoc Ø 8/5 (2pcs) / Anti-golpes en silicona Ø 8/5 (2pzs)
7	41421807650	Porta focolare completa / Fireplace door / Feuerstelle Tür / Porte foyer / Puerta hogar
8	41401617540	Cassetto cenere completo / Complete ash drawer / Kompletter Aschekasten / Tiroir à cendres complet / Cajón cenizas completo
9	4141164511000	Tappo camera fumi / Smoke compartment plug / Rauchabzugklappe / Couvercle compartiment fumées / Tapón compartimento humos
10	41801603600	Guarnizione tappo fumi / Smoke plug gasket / Dichtung Rauchgasverschluss / Joint clapet fumées / Junta tapa humos
11	41801603500	Guarnizione focolare / Gasket / Dichtung / Joint / Junta
12	4140203393000	Base braciere / Brazier base / Brennertopf Basis / Base de brasero / Base brasero
13	41301601600V	Braciere in ghisa autopulente / Self-cleaning cast iron brazier / Selbstreinigend Brennertopf aus Gusseisen / Brasero en fonte autonettoyant / Brasero en arrabio autolimpiador
14	41151600300	Isolante frontale / Front panell insulating material / Vorderes Panel Isolationsmaterial / Isolant panneau antérieur / Aislante panel frontal
15	41801400200	Piedini di appoggio (4 pz.) / Support feet (4 pcs.) / Einstellfüße (4 Stck.) / Vérins d'appui (4 p.es) / Pies de apoyo (4 piezas)
16	41401631130	Vassoio raccolta cenere / Ash collection tray / Aschenlade / Plateau recuperateur des cendres / Bandeja de recogida de cenizas
17	41411646840P	Fianco inferiore Dx / RH lower side / Unteres Re. Seitenteil / Côte inférieur D. / Lateral inferior DCHO
18	41411646730P	Fianco superiore Dx / RH upper side / Obere Re. Seitenteil / Côte supérieur D. / Lateral superior DCHO
19	41401616030	Angolare anteriore destro / Right front angular / Recht Eckig Vorderseite / Angulaire avant droite / Ángular frontal derecho
20	4141164521000	Tappo struttura / Structure plug / Strukturklappe / Clapet de la structure / Tapón estructura
21	41801603700	Guarnizione tappo struttura / Gasket structure plugs / Dichtung Strukturklappe / Joint clapets de la structure / Junta tapónes estructura
22	41801657900	Magneti (pz.2) / Magnet (pcs.2) / Magnet (stk. 2) / Aimant (pcs.2) / Imán (pz.2)
23	4120180	Gommini paracolpi (4 pz) / Rubber bumpers (4 pcs.) / Schlagschutzgummi (4 Stck) / Pièces caoutchouc antichoc (4 pcs) / Cauchitos anti-golpes (4 pz)
24	41401615830	Angolare anteriore / Front angular / Eckig Vorderseite / Angulaire avant / Ángular frontal
25	41401615930	Supporto cerniere / Hinges support / Scharniere-Halterung / Support des charnières / Soporte de bisagras
26	41411646930P	Fianco intero / LH side / Li. Seitenteil / Côte G. / Lateral IZDO
27	41401617130	Coperchio posteriore / Rear cover / Hintere Deckel / Couvercle postérieur / Tapa posterior
28	41401617010	Coperchio posteriore / Rear cover / Hintere Deckel / Couvercle postérieur / Tapa posterior
29	41401616930	Pannello inferiore / Bottom panel / Bodenplatte paneel / Panneau du bas / Panel inferior
30	41401616830	Pannello posteriore / Back panel / Hintere Paneel / Panneau posterieur / Panel posterior
31	41401618930	Griglia antintrusione / Hopper protection grille / Schutzgitter Pelletbehälter / Grille de protection réservoir / Rejilla de protección depósito
32	41401616630	Pannello stagno / Air-tight panel / Luftdich Platte / Panneau étanche / Panel hermético
33	41401616240	Cornice superiore completa / Complete upper frame / Voller oberer Rahmen / Cadre supérieur complet / Marco superior completo
34	41201501900	Antivibranti (10 pz) / Anti-vibration mountings (10 pcs) / Schwingungsdämpfend (10 Stck.) / Eléments antivibrations (10 pcs) / Anti-vibraciones (10 pzs)
35	41801208000	Guarnizione - 5 m / Gasket - 5 m / Dichtung - 5 m / Joint - 5 m / Junta - 5 m
35	41801208001	Guarnizione - 50 m / Gasket - 50 m / Dichtung - 50 m / Joint - 50 m / Junta - 50 m
35	41801208002	Guarnizione - 2,5 m / Gasket - 2,5 m / Dichtung - 2,5 m / Joint - 2,5 m / Junta - 2,5 m
36	4141164503000	Piastrina coperchio / Cover plate / Deckplatte / Plaque de couverture / Placa de cubierta
37	41801001500	Magnete / Magnet / Magnet / Aimant / Imán

38	41411645850	Coperchio completo caldaia / Complete boiler cover / Komplet Deckel Kessel / Couvercle chaudière complét / Tapa caldera completa
39	41201104500	Cerniera pz.2 / Hinge Pcs.2 / Scharnier St.2 / Charnière Pcs.2 / Bisagra Pz.2
40	41411646150	Coperchio completo serbatoio / Complete hopper cover / Komplet Deckel Pelletbehälter / Couvercle réservoir complét / Tapa depósito completa
41	41801101400	Pistone a gas / Gas-piston / Gas-Kolben / Piston à gaz / Pistón a gas
42	4140090284200	Supporto chiusura porta / Door closing support / Türschließ Halterung / Support de fermeture de porte / Soporte de cierre de puerta

PERFORMA 25 HQ EASY CLEAN H1

Porta fuoco / Fire door / Feuertür / Porte foyer / Puerta hogar

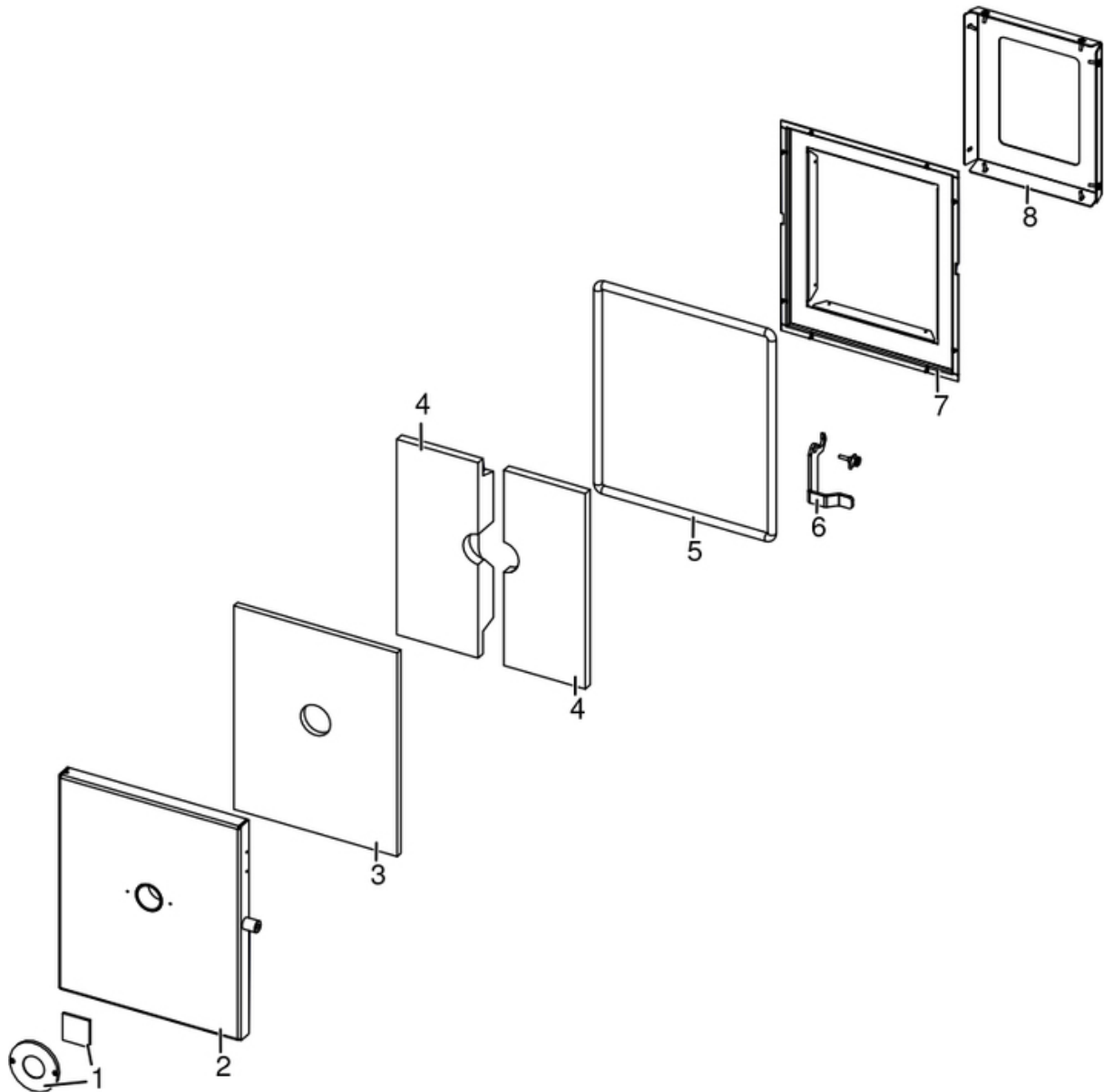

N°	Codice/Code	Descrizioni / Description / Beschreibung / Description / Descripción
1	41201302800V	Spioncino con vetro - Spioncino Ø 40 / Peephole with glass - Peephole Ø 40 / Guckloch mit Scheibe - Guckloch Ø 40 / Judas avec vitre - Judas Ø 40 / Mirilla con cristal - Mirilla Ø 40
2	41401132742V	Telaio esterno porta fuoco - Spioncino Ø 40 / External door frame - Peephole Ø 40 / Aussere Feuertürrahmen - Guckloch Ø 40 / Cadre extérieure porte - Judas Ø 40 / Armazón externo puerta - Mirilla Ø 40
3	41151101202	Isolante interno - Spioncino Ø 40 / Internal insulating material - Peephole Ø 40 / Innerer Isolationsmaterial - Guckloch Ø 40 / Isolant intérieur - Judas Ø 40 / Aislante interno - Mirilla Ø 40
4	41151600600	Isolante porta focolare / Fireplace door insulating material / Feuerstelle Tür Isolationsmaterial / Isolant porte foyer / Aislante puerta hogar
5	412007003A	Cordino fibroceramico Ø 14 mm (5 mt.) / Ceramic fibre cord Ø 14 mm (5 m.) / Keramikfaserschnur Ø 14 mm (5 m) / Cordon en fibre céramique Ø 14 mm (5 m) / Junta a cuerda de fibra cerámica Ø 14 mm (5 m)
5	412007003B	Cordino fibroceramico Ø 14 mm (50 mt.) / Ceramic fibre cord Ø 14 mm (50 m.) / Keramikfaserschnur Ø 14 mm (50 m) / Cordon en fibre céramique Ø 14 mm (50 m) / Junta a cuerda de fibra cerámica Ø 14 mm (50 m)
5	412007003C	Kit sostituzione cordino (cordino+silicone) Ø 14 mm / Cord replacement kit (cord + silicon) Ø14 mm / Schnuraustauschsatz (Schnur +Silikon) Ø 14 mm / Kit remplacement cordon (cordon+silicon) Ø 14 / Kit sustitución junta a cuerda (junta a cuerda+silicón) Ø 14 mm
6	4141187733000	Maniglia porta focolare / Fire door handle / Feuertür Griff / Poignée porte foyer / Tirador puerta fuego
7	41411647130V	Pannello interno / Internal panel / Inner Paneel / Panneau intérieur / Panel interior
8	41401619130	Scudo porta completo / Fireplace door cover / Feuerstelle Tür Abdeckung / Coverture porte foyer / Tapa puerta hogar
8	41402074930	Scudo porta completo INOX / Fireplace door cover INOX / Feuerstelle Tür Abdeckung INOX / Coverture porte foyer INOX / Tapa puerta hogar INOX

PERFORMA 25 HQ EASY CLEAN H1

Gruppo caricamento pellet / Pellet feed group / Pellet Fördergruppe / Groupe chargement du pellet / Grupo de carga pellet

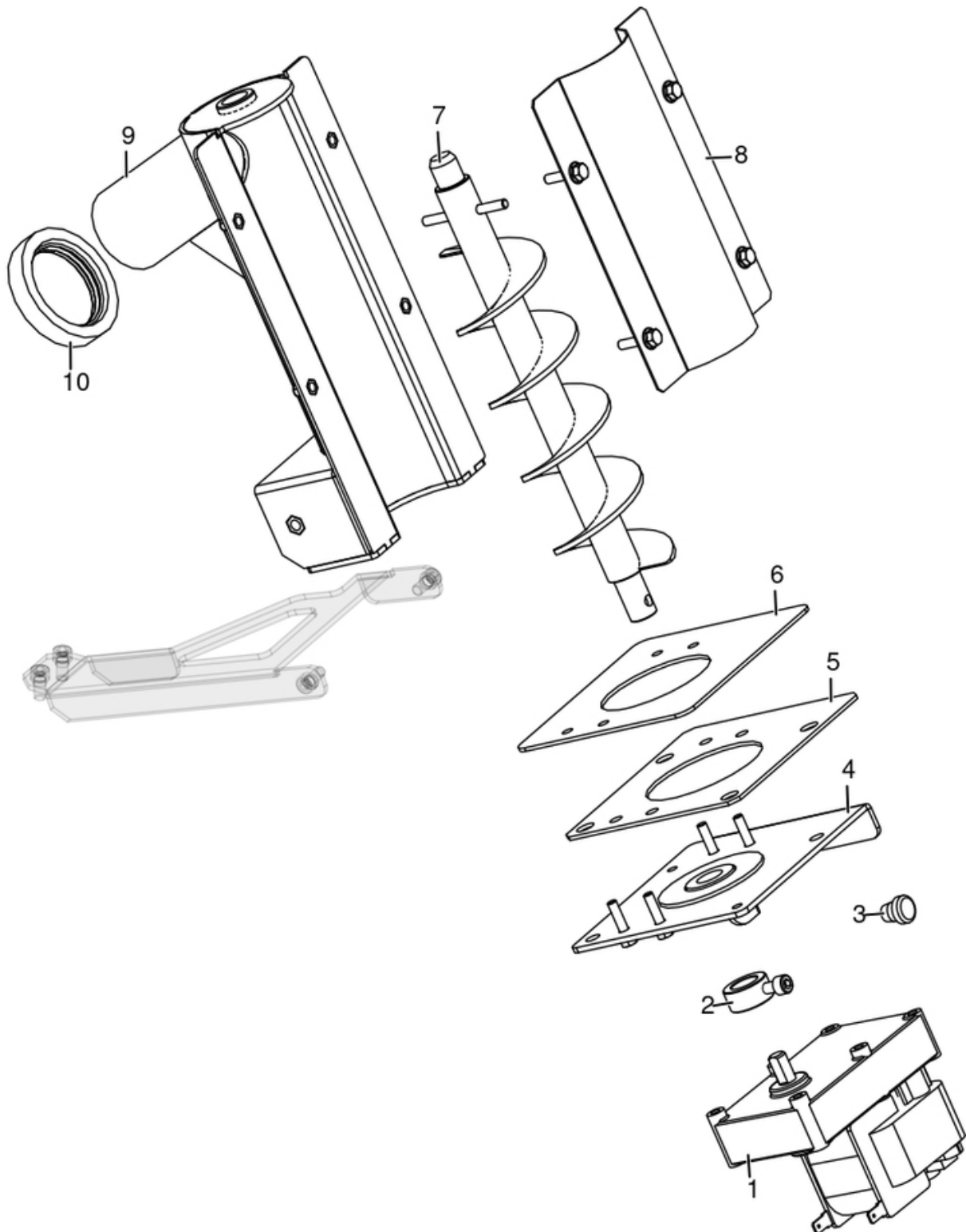

N°	Codice/Code	Descrizioni / Description / Beschreibung / Description / Descripcion
1	41451204900	Motoriduttore 3,3 RPM / Reduction motor 3,3 RPM / Getriebemotor 3,3 RPM / Motoréducteur 3,3 RPM / Motorreductor 3,3 RPM
2	4120398	Connettore motoriduttore-coclea / Reduction motor-feed screw connector / Verbindung Getriebemotor-Schnecke / Connecteur motoréducteur-vis sans fin / Conector motorreductor-cóclea
3	4120180	Gommini paracolpi (4 pz) / Rubber bumpers (4 pcs.) / Schlagschutzgummi (4 Stck) / Pièces caoutchouc antichoc (4 pcs) / Cauchitos anti-golpes (4 pz)
4	41411688850	Base della coclea / Feed screw base / Untergestell der Förderschnecke / Base de la vis sans fin / Base de la cóclea
5	4120615	Guarnizione base della coclea / Feed screw base gasket / Dichtung Untergestell der Förderschnecke / Joint pour la base de la vis sans fin / Junta base de la cóclea
6	41400903310	Flangia condotto coclea / Base of feed screw conduit / Untergestell Rohrleitung der Förderschnecke / Base du conduit de la vis sans fin / Base de conducto de la cóclea
7	41402030240	Albero coclea / Auger shaft / Förderschnecke / Vis sans fin / Cóclea
8	41401227530	Coperchio coclea / Feed screw cover / Deckel der Rohrleitung / Couvercle de la vis sans fin / Tapa de la cóclea
9	41411650640V	Condotto alimentazione / Auger conduit / Rohrleitung der Förderschnecke / Conduit de la vis sans fin / Conducto de la cóclea
10	41801501900	Guarnizione silicone / Silicon gasket / Silikondichtung / Joint en silicone / Junta en silicóna
10	41801702600	Disaccoppiatore mesc. Marrone / Brown disengaging device / Braun Verängungsrohr / Tuyau de découplage maron / Tubo de desvio marron

PERFORMA 25 HQ EASY CLEAN H1

Gruppo accensione e aria comburente / Ignition and combustion air group / Entzündungs- und Verbrennungsluftgruppe / Groupe allumage et aire comburente / Grupo encendido y aire de combustion

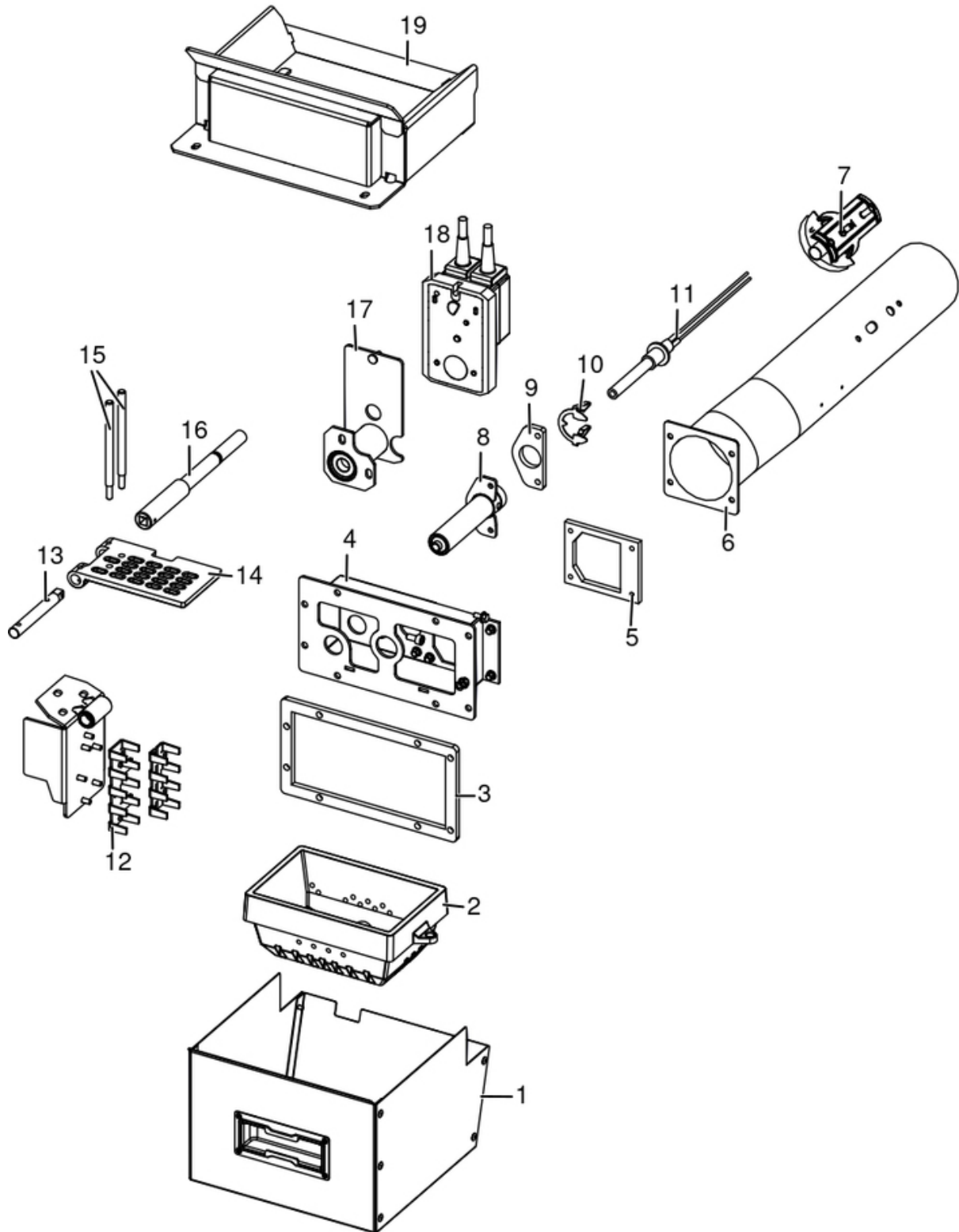

N°	Codice/Code	Descrizioni / Description / Beschreibung / Description / Descripcion
1	41401617540	Cassetto cenere completo / Complete ash drawer / Kompletter Aschekasten / Tiroir à cendres complet / Cajón cenizas completo
2	41301601600V	Braciere in ghisa autopulente / Self-cleaning cast iron brazier / Selbstreinigend Brenntopf aus Gusseisen / Brasero en fonte autonettoyant / Brasero en arrabio autolimpiador
3	41801604000	Guarnizione scatola aspirazione / Aspiration box gasket / Saugkastendichtung / Joint de boîte d'aspiration / Junta de la caja de succión
4	41411647940V	Scatola aspirazione / Air inlet box / Lufteingangs Schachtel / Coffret entrée d'air / Caja entrada aire
5	41801603800	Guarnizione tubo aspirazione / Aspiration pipe gasket / Saugrohrdichtung / Joint de tuyau d'aspiration / Junta de tubo de succión
6	41601603500V	Tubo aspirazione nero / Black air inlet pipe / Schwarz Lufteingangsrohr / Tuyau entrée d'air noir / Tubo entrada aire negro
7	41601306150	Componente rilevamento portata aria / Air flow measure component / Bauteil für Messung der Luftmenge / Composant pour la mesuration de la quantité d'air / Componente por la medida de l'aire
8	41411648240V	Condotto candeletta / Sparkplug duct / Zündkerzenkanal / Conduit bougie / Conducto bujía
9	41801603900	Guarnizione condotto candeletta / Sparkplug conduit gasket / Dichtung Zündkerzenkanal / Joint conduit bougie / Junta conducto bujía
10	41201601500	Anello arresto candeletta / Sparkplug stop / Zündkerzestopper / Butée bougie / Tope bujía
11	41451308101	Candeletta 315 Watt / Sparkplug 315 Watt / Zündkerze 315 Watt / Bougie 315 Watt / Bujía 315 Watt
11	41451308150	Kit 25 candelette 315 Watt / 25 Sparkplugs 315 Watt kit / Bausatz 25 Zündkerzen 315 Watt / Kit 25 Bougies 315 Watt / Kit 25 Bujías 315 Watt
12	41411649050	Pettine pulitore completo / Complete scraper / Komplet Kratzer / Racleur complète / Raspador completo
13	41201604700	Asse mobile / Moving axis / Bewegliche Achse / Axe mobile / Eje móvil
14	41301601700V	Fondello in ghisa braciere autopulente nero / Self-cleaning cast iron barzier bottom / Selbstreinigend Brenntopf aus Gusseisen Boden / Fond brasero autonettoyant en fonte / Fondo brasero autolimpiador en arrabio
15	41201607900	Perno griglia (pz.2) / Pivot for grille (Pcs.2) / Bolzen für Gitter (Stk.2) / Pivot pour grille (Pcs.2) / Perno para rejilla (Pz.2)
16	41201604600	Asse Belimo / Actuator shaft / Trieb Bolzen / Pivot actionneur / Perno actuador
17	41411648450	Supporto Belimo / Actuator support / Halterung Trieb / Support actionneur / Soporte actuador
18	41451203300	Attuatore / Actuator / Trieb / Actionneur / Actuador
19	41402033740	Scivolo braciere / Brazier slide / Kohlenbecken Rutsche / Glissière de brasero / Tobogán brasero

PERFORMA 25 HQ EASY CLEAN H1

Gruppo elettrico ed elettronico / Electrical and electronic group / Elektrische und elektronische Gruppe / Groupe électrique et électronique / Grupo eléctrico y electrónico

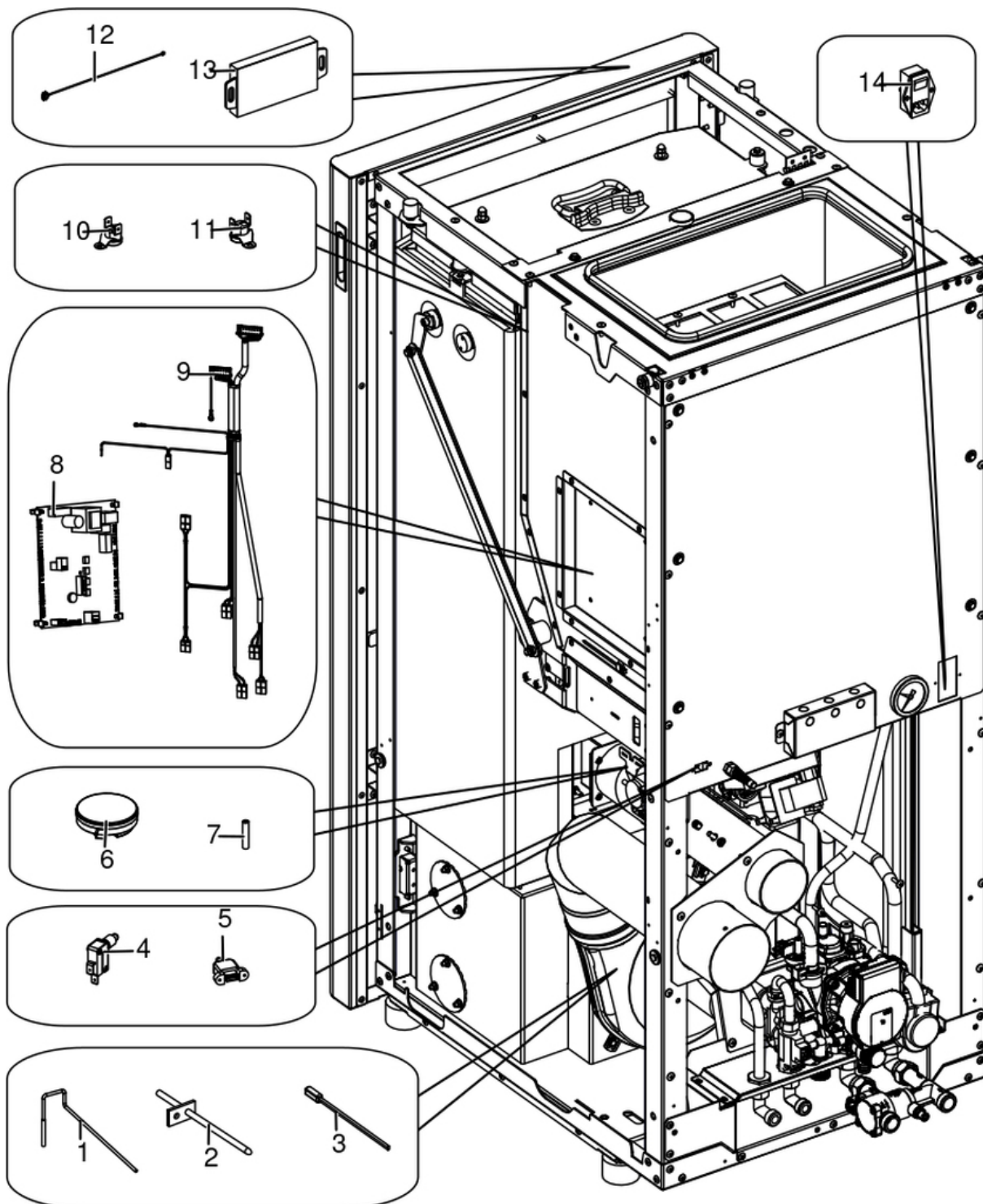

N°	Codice/Code	Descrizioni / Description / Beschreibung / Description / Descripción
1	4012062	Sonda NTC a filo per acqua / Water temperature sensor / Wassertemperaturfühler / Sonde température eau / Sonda temperatura agua
2	41451601700	Sonda fumi / Smoke sensor / Rauchgasfühler / Sonde fumées / Sonda humos
3	4160386	Sonda temperatura ambiente/acqua / Room/Water temperature sensor / Raum- Wassertemperaturfühler / Sonde température ambiance/eau / Sonda temperatura ambiente/agua

4	4160457	Pulsante per l'interruzione dell'alimentazione elettrica / power supply on-off button / Taste zur Unterbrechung der Stromversorgung / Bouton d'arrêt de l'alimentation électrique / Botón de corte de la alimentación eléctrica
5	41451403200	Cavo USB da pannello L.500 / USB Cable from display L.500 / USB Kabel von Notfalldisplay L.500 / Câble USB de panneau L.500 / Cable USB del panel L.500
6	4160482	Pressostato 0,4 mbar / Pressure gauge 0,4 mbar / Druckschalter 0,4 mbar / Pressostat 0,4 mbar / Presostato 0,4 mbar
7	4120631A	Tubicino siliconico - 5m / Silicon tube - 5m / Silikonrohr - 5m / Petit tuyau en silicone - 5m / Tubo silicónico - 5m
8	41451303807	Scheda madre Hottoh 149 / Hottoh motherboard 149 / Hauptplatine Hottoh 149 / Carte mère Hottoh 149 / Tarjeta madre Hottoh 149
9	41451601802	Cablaggio completo / Complete wiring / Komplette Verkabelung / Câblage complet / Cableado completo
10	412007004	Clickson 110°C / Clickson 110°C / Clickson 110°C / Clickson 110°C / Clickson 110°C
11	41451601900	Termostato a contatto / Thermostat / Thermostat / Thermostat / Termóstato
12	41451303600	Cavo connessione pannello / Control panel connection cable / Bedienblende Verbindungskabel / Cable de connection au tableau / Cable de conexión panel de comando
13	41451303706	Pannello comandi Hottoh 129 / Control panel Hottoh 129 / Bedienblende Hottoh 129 / Tableau de commande Hottoh 129 / Panel de mandos Hottoh 129
14	4160193	Pulsante accensione / On/Off button / Zündungstaste / Touche d'allumage / Botón encendido

PERFORMA 25 HQ EASY CLEAN H1

Gruppo fumi / Smoke group / Rauchgruppe / Groupe fumées / Grupo de humos

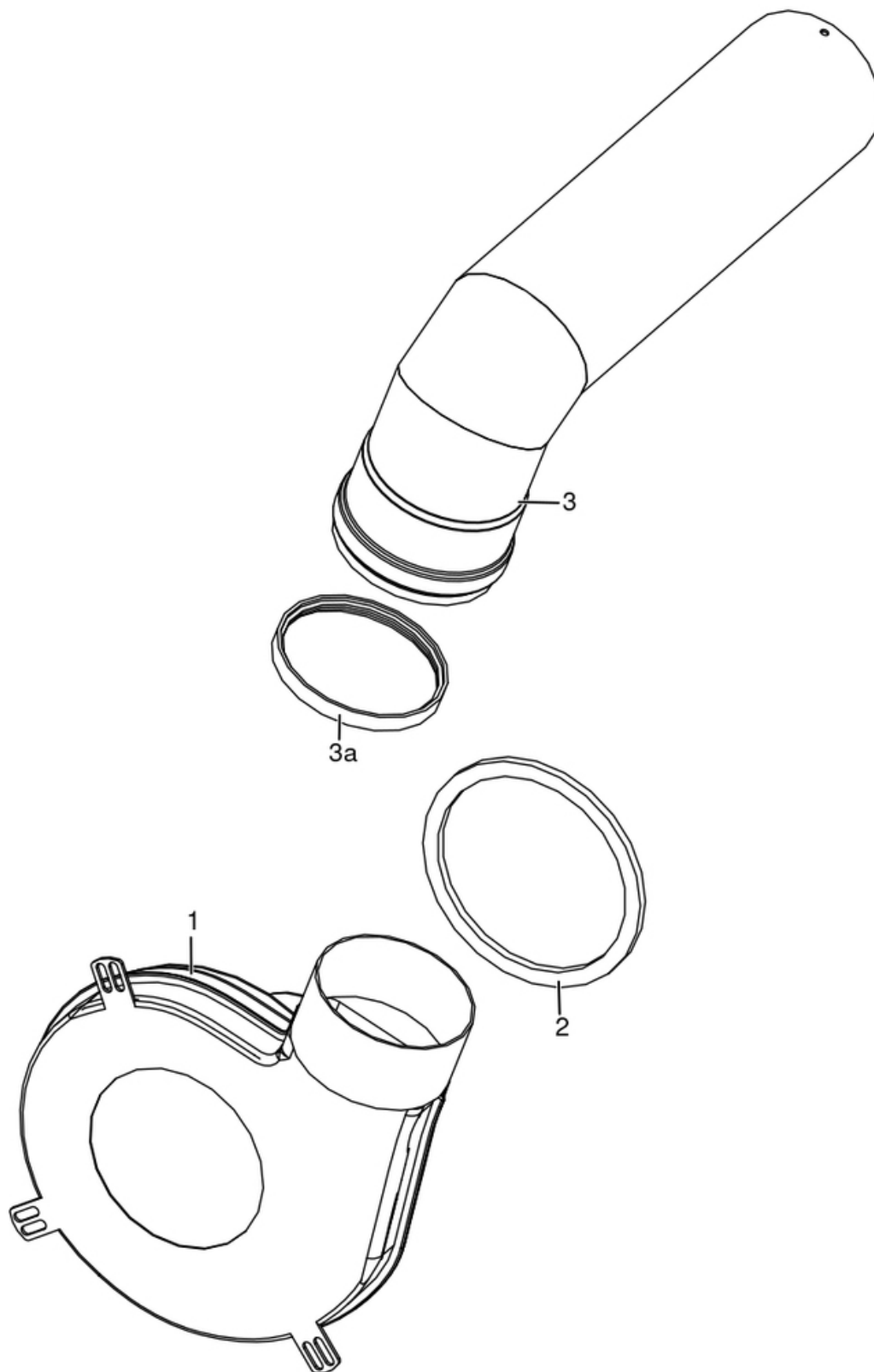

N°	Codice/Code	Descrizioni / Description / Beschreibung / Description / Descripcion
1	41451201750	Ventilatore fumi / Smoke exhaust fan / Rauchabsauggebläse / Ventilateur aspiration fumées / Ventilador aspiración de humos
2	41801100100	Guarnizione adesiva voluta fumi / Adhesive gasket smoke volute / Haftendichtung Rauchvolute / Joint adhesive volute fumées / Junta adhesiva voluta humos
3	41601103960	Tubo uscita fumi / Smoke outlet pipe / Rohr Rauchabzug / Tuyau sortie fumées / Tubo salida humos
3a	40A12022	Guarnizione Ø 100 - 5 Pz / Gasket Ø 100 - 5 Pcs / Dichtung Ø 100 - 5 Stck / Joint Ø 100 - 5 Pcs / Junta Ø 100 - 5 Pzs

PERFORMA 25 HQ EASY CLEAN H1

Gruppo componenti idraulici / Hydraulic components group / Hydraulische Komponenten / Groupe de composants hydrauliques / Grupo de componentes hidráulicos

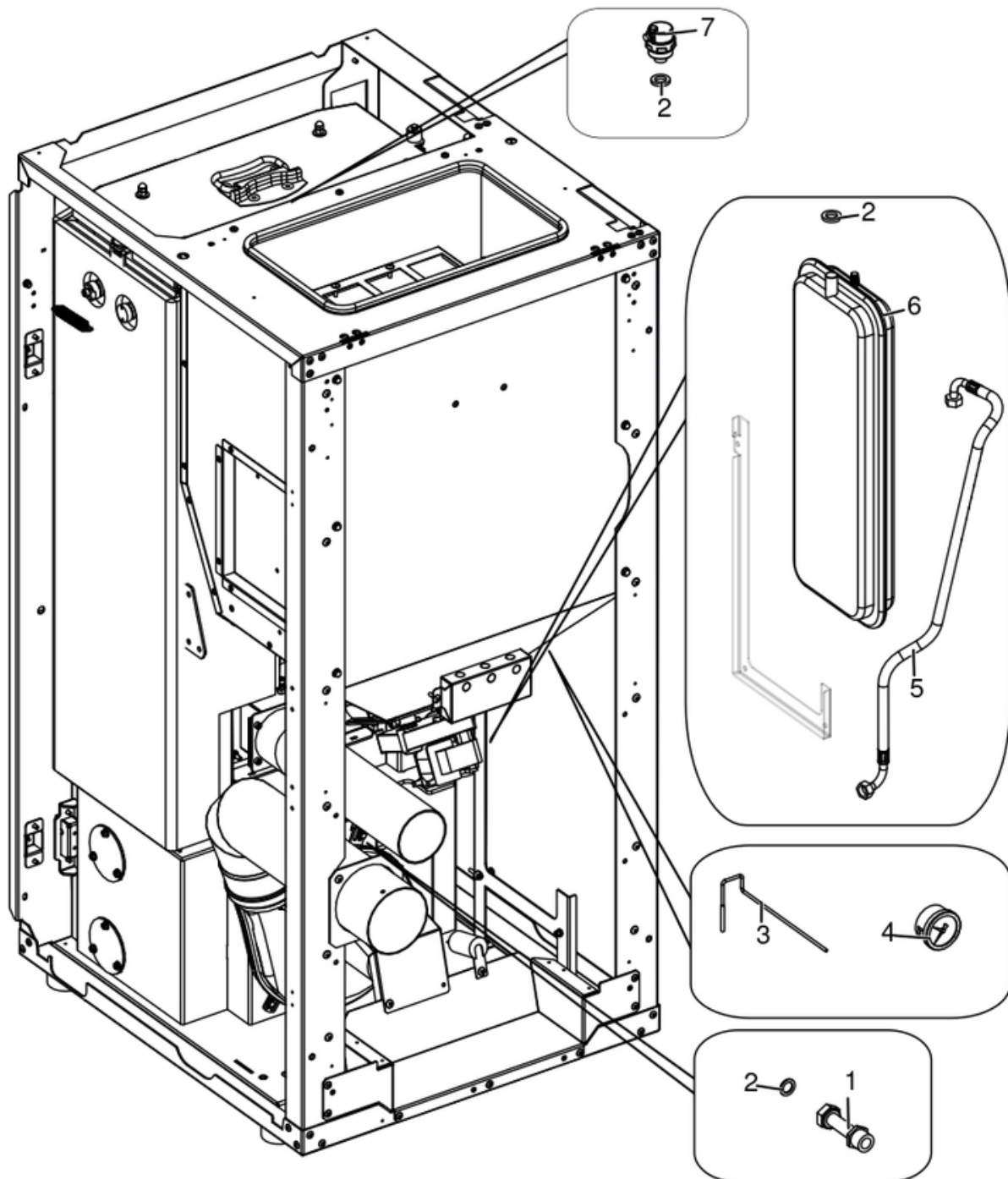

N°	Codice/Code	Descrizioni / Description / Beschreibung / Description / Descripción
1	41501602000	Raccordo mandata impianto / Delivery tube connection / Vorlaufrohr Verbindung / Raccord tuyau refoulement / Raccor tubo de envío
2	41207910	Kit guarnizioni impianto idraulico / Hydraulic system gasket kit / Dichtungsbausatz für Hydraulikanlage / Kit de joints pour l'installation hydraulique / Kit de juntas de la instalación de fontanería
3	4012062	Sonda NTC a filo per acqua / Water temperature sensor / Wassertemperaturfühler / Sonde température eau / Sonda temperatura agua
4	41501100901	Manometro / Manometer / Manometer / Manomètre / Manómetro
5	41501100800	Tubo di mandata acqua da caldaia / Boiler water delivery tube / Vorlaufrohr Wasser vom Kessel / Tuyau de refoulement eau de la chaudière / Tubo de envío de agua de la caldera
6	4120775	Vaso espansione (6 l) / Expansion vessel (6 l) / Expansionsgefäß (6 l) / Vase d'expansion (6 l) / Vaso de expansión (6 l)
7	4120779	Valvola di sfiato / Vent valve / Entlüftungsventil / Soupape de dégagement / Válvula respiradero

PERFORMA 25 HQ EASY CLEAN H1

Gruppo scambiatore / Exchanger group / Austausch Baugruppe / Groupe échangeur / Grupo intercambiador

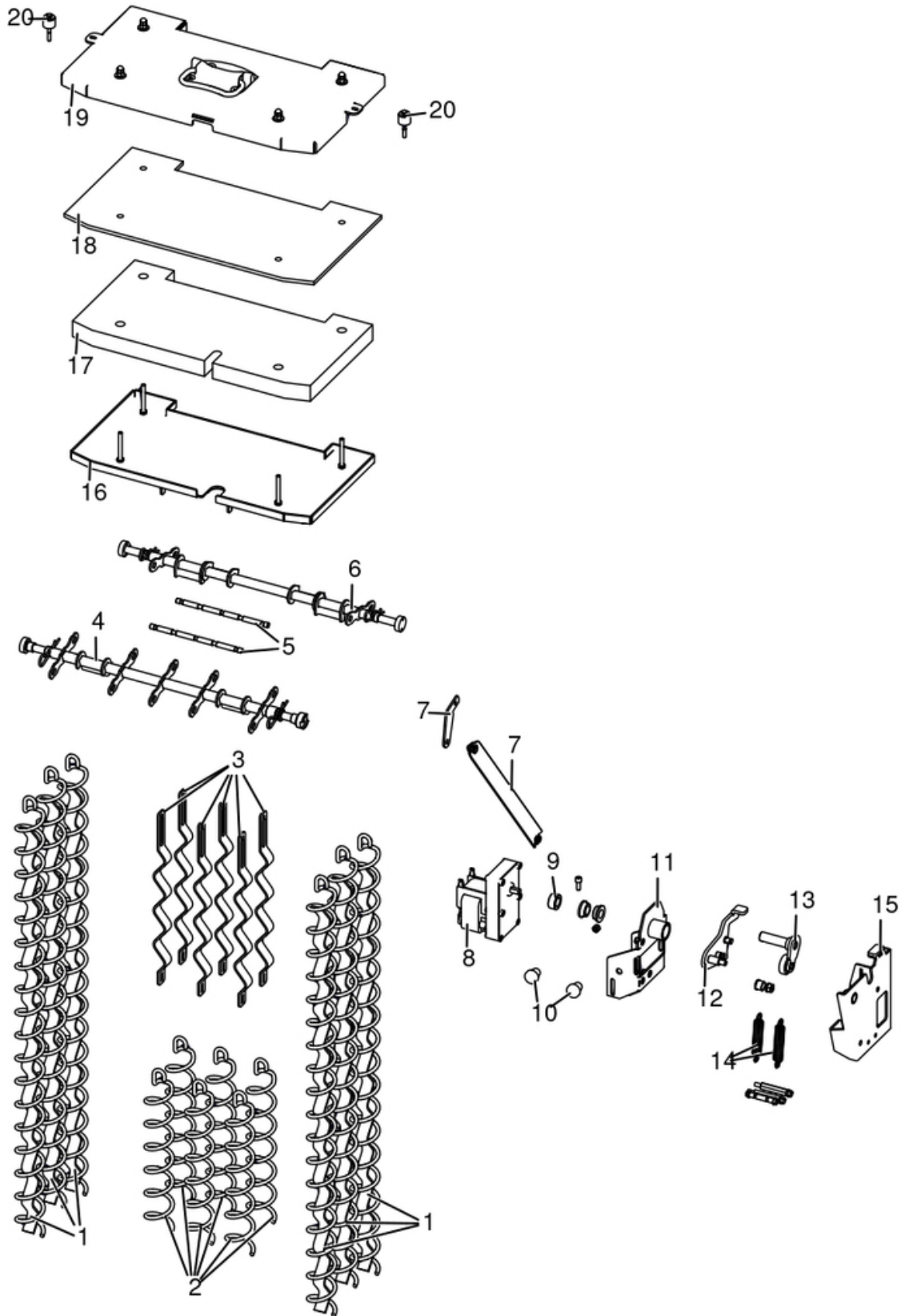

N°	Codice/Code	Descrizioni / Description / Beschreibung / Description / Descripcion
1	41331602240	Turbolatore lungo / Turbulator / Propeller des Schabers / Turbulateur / Rascador
2	41201302400	Eliche raschiatore Inox (1 pz.) / Inox Turbulator props (1 pc.) / Propeller des Schabers Inox (1 Teil) / Hélices turbulateur Inox (1 pz.) / Hélice rascador Inox (1 pz.)
3	41331602500	Turbolatore ad onda inox / Inox turbolator / Inox Turbulator / Turbulateur Inox / Rascador Inox
4	41401700150	Asse turbolatori anteriori / Front turbolator shaft / Vordere Turbulator Stange / Tige turbolateurs antérieurs / Asta rascadores anteriores
5	41201605100	Spina turbolatori corti / Turbulator pin / Turbulator Bolzen / Pivot pour turbolateur / Perno para rascador
6	41331602040	Asse turbolatori posteriori / Rear turbolator shaft / Hintere Turbulator Stange / Tige turbolateurs postérieurs / Asta rascadores posteriores
7	4141169834000	Biella movimentazione albero turbolatori / Connecting rod for the movement of turbolator props axle / Kuppelstange für Bewegung der Reinigungsspiralenwelle / Bielle pour le mouvement de l'arbre des hélices turbolateur / Biela movimiento Eje de l'hélice rascador
8	41450901600	Motoriduttore 3,3 rpm Merkle Korff / Reduction motor 3,3 rpm Merkle Korff / Getriebemotor 3,3 RPM MERKLE KORFF / Motorréducteur 3,3 RPM MERKLE KORFF / Motorreductor 3,3 rpm Merkle Korff
9	4120398	Connettore motoriduttore-coclea / Reduction motor-feed screw connector / Verbindung Getriebemotor-Schnecke / Connecteur motorréducteur-vis sans fin / Conector motorreductor-cóclea
10	4120180	Gommini paracolpi (4 pz) / Rubber bumpers (4 pcs.) / Schlagschutzgummi (4 Stck) / Pièces caoutchouc antichoc (4 pcs) / Cauchitos anti-golpes (4 pz)
11	41411649740V	Supporto motoriduttore / Reduction motor support / Schneckenmotor Gestell / Support motorréducteur / Soporte motoreductor
12	4141170184000	Rinvio / Gear / Vorgelege / Transmission / Contramarcha
13	41411701250	Camma turbolatore / Turbulator cam / Turbulator Nocke / Came de turbulateur / Leva del turbolador
14	41201608900	Molla trazione (pz.2) / Spring (pcs.2) / Feder (Stk.2) / Ressort (pcs.2) / Ressorte (pz.2)
15	4141170154000	Supporto / Support / Haltebügel / Support / Soporte
16	41331602640	Involucro inferiore completo / Lower complete casing / Untere komplett Hülle / Enveloppe complète inférieure / Envoltura inferior completa
17	41151601200	Isolante coperchio / Cover insulating material / Deckel Isolationsmaterial / Isolant couvercle / Aislante tapa
18	41151601100	Isolante coperchio / Cover insulating material / Deckel Isolationsmaterial / Isolant couvercle / Aislante tapa
19	41411650240V	Coperchio testata / Cover / Deckel / Couvercle / Tapa
20	41801499550	Kit scarico sovrappressione camera di combustione (pz.2) / Pressure relief kit (Pcs.2) / Bausatz überdruckablauf brennkammer (Stck.2) / Kit decompression chambre combustion (Pcs.2) / Kit descompresion camara combustion (Pcs.2)

PERFORMA 25 HQ EASY CLEAN H1

40A18013 kit circolatore AE / 40A18013 circulation kit high efficiency / 40A18013 Hochleistungs-Zirkulationskit / 40A18013 kit circulateur à haut rendement / 40A18013 kit bomba alto rendimiento

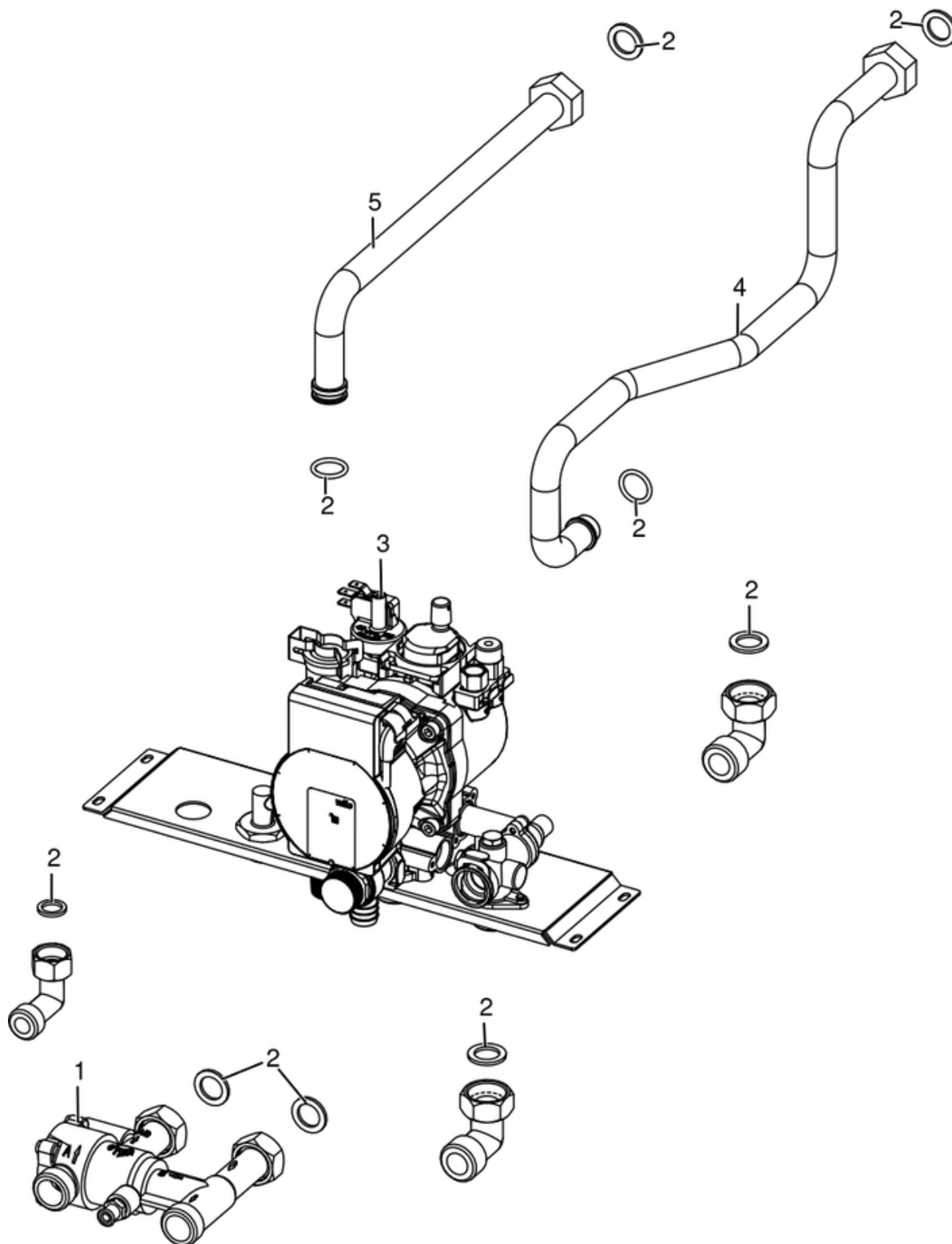

N°	Codice/Code	Descrizioni / Description / Beschreibung / Description / Descripción
1	41501806000	Valvola anticondensa 3/4" ACV/4 / 3/4 "ACV/4 anti-condensation valve / 3/4 "ACV/4 Antikondensationsventil / Vanne anti-condensation 3/4 "ACV/4 / Válvula anticondensación 3/4 "ACV/4
2	41207910	Kit guarnizioni impianto idraulico / Hydraulic system gasket kit / Dichtungsbausatz für Hydraulikanlage / Kit de joints pour l'installation hydraulique / Kit de juntas de la instalación de fontanería
3	41501602151	Kit idraulico - solo riscaldamento / Hydraulic unit - heating only / Hydraulikeinheit - nur Heizung / Unité hydraulique - seul chauffage / Unidad hidráulica - solo calentamiento
3	41502002100	Circolatore Wilo Para 7 IPWM / Water circulation pump Wilo Para 7 IPWM / Umwälzpumpe Wilo Para 7 IPWM / Pompe de circulation Wilo Para 7 IPWM / Bomba de circulación agua Wilo Para 7 IPWM
3	41501305100	Rubinetto a spillo / Needle valve / Nadelventil / Soupape à pointeau / Válvula de aguja
3	41501103300	Valvola di sicurezza 3 Bar / Maximum pressure valve 3 Bar / Sicherheitsventil 3 Bar / Soupape de pression maximale 3 Bar / Válvula máxima presión 3 Bar
3	41451108000	Pressostato di minima H2O / Pressur switch H2O / Druckwächter H2O / Pressostat H2O / Presostato H2O
4	41501602400	Tubo ritorno kit idraulico / Pump connection tube / Verbindungsrohr zur Pumpe / Tuyau de connection à la pompe / Tubo de conexión a la bomba
5	41501602300	Tubo mandata kit idraulico / Heating water delivery tube / Heizungsvoorlaufrohr / Tuyau de refoulement eau chauffage / Tubo de envío de agua calentamiento

PERFORMA 25 HQ EASY CLEAN H1

40A18014 kit circolatore AE ACS / 40A18014 circulation kit high efficiency DHW / 40A18014 Hochleistungs-Zirkulationskit ACS / 40A18014 kit circulateur à haut rendement ACS / 40A18014 kit bomba alto rendimiento ACS

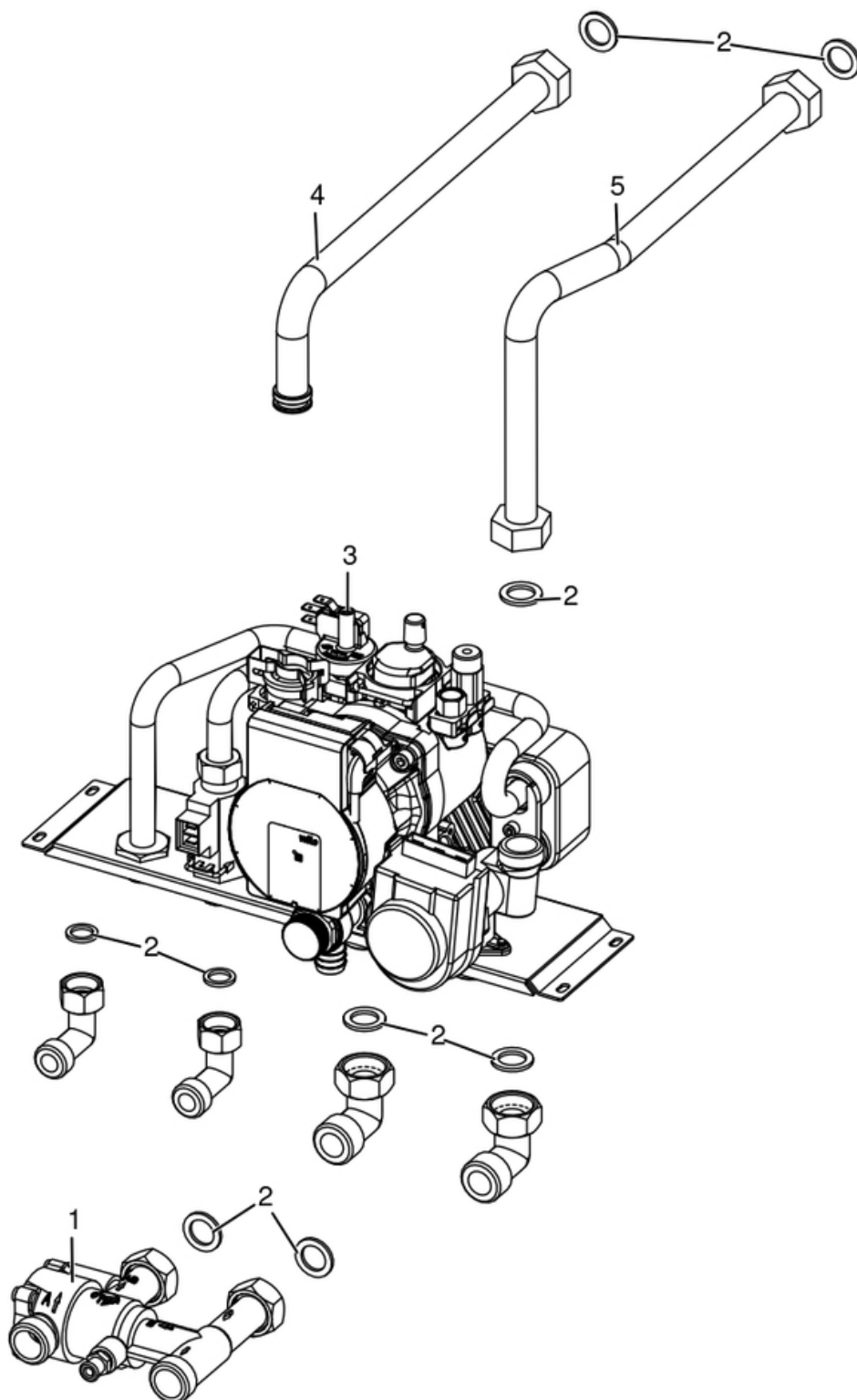

N°	Codice/Code	Descrizioni / Description / Beschreibung / Description / Descripción
1	41501806000	Valvola anticondensa 3/4" ACV/4 / 3/4 "ACV/4 anti-condensation valve / 3/4 "ACV/4 Antikondensationsventil / Vanne anti-condensation 3/4 "ACV/4 / Válvula anticondensación 3/4 "ACV/4
2	41207910	Kit guarnizioni impianto idraulico / Hydraulic system gasket kit / Dichtungsbausatz für Hydraulikanlage / Kit de joints pour l'installation hydraulique / Kit de juntas de la instalación de fontanería
3	41501602250	GRUPPO IDRAULICO - CON PRODUZIONE ACQUA SANITARIA / HYDRAULIC UNIT - WITH DOMESTIC HOT WATER PRODUCTION / HYDRAULIKEINHEIT - MIT BRAUCHWARMWASSER HERSTELLUNG / UNITÉ HYDRAULIQUE - AVEC PRODUCTION EAU CHAUDE SANITAIRE / UNIDAD HIDRÁULICA - CON PRODUCCIÓN AGUA CALIENTE SANITARIA
3	41502002100	Circolatore Wilo Para 7 IPWM / Water circulation pump Wilo Para 7 IPWM / Umwälzpumpe Wilo Para 7 IPWM / Pompe de circulation Wilo Para 7 IPWM / Bomba de circulación agua Wilo Para 7 IPWM
3	41501205800	Flussostat / Water flow sensor / Flusswächter / Fluxostat / Flujostat
3	41451108100	Motore valvola 3 vie / 3-way valve motor / 3-Wegeventil Motor / Moteur de la vanne 3 voies / Motor de la válvula de 3 vías
3	41501103500	Scambiatore sanitario 14 piastre / Heat exchanger 14 plates / Wärmetauscher 14 Platten / Échangeur sanitaire 14 plaques / Intercambiador sanitario 14 placas
3	41501103300	Valvola di sicurezza 3 Bar / Maximum pressure valve 3 Bar / Sicherheitsventil 3 Bar / Soupape de pression maximale 3 Bar / Válvula máxima presión 3 Bar
3	41451108000	Pressostato di minima H2O / Pressur switch H2O / Druckwächter H2O / Pressostat H2O / Presostato H2O
3	41801204500	Forcella tubo ø18 / Fork pipe ø18 / Gabel-Rohr ø18 / Fourche je roucoule ø18 / Horquilla arrullo ø18
3	41401143700	Forcella per tubo Ø18 / Fork for pipe ø18 / Gabel-Rohr ø18 / Fourche pour tube Ø18 / Horquilla para tubo Ø18
4	41501602300	Tubo mandata kit idraulico / Heating water delivery tube / HeizungsVorlaufrohr / Tuyau de refoulement eau chauffage / Tubo de envío de agua calentamiento
5	41501602500	Tubo ritorno kit idraulico con ACS / Pump connection tube / Verbindungsrohr zur Pumpe / Tuyau de connection à la pompe / Tubo de conexión a la bomba