

PLASMA 95 WOOD

Componenti Struttura Esterna / External structure components / Bauteile Aussenkorpus / Composants structure externe / Componentes estructura externa

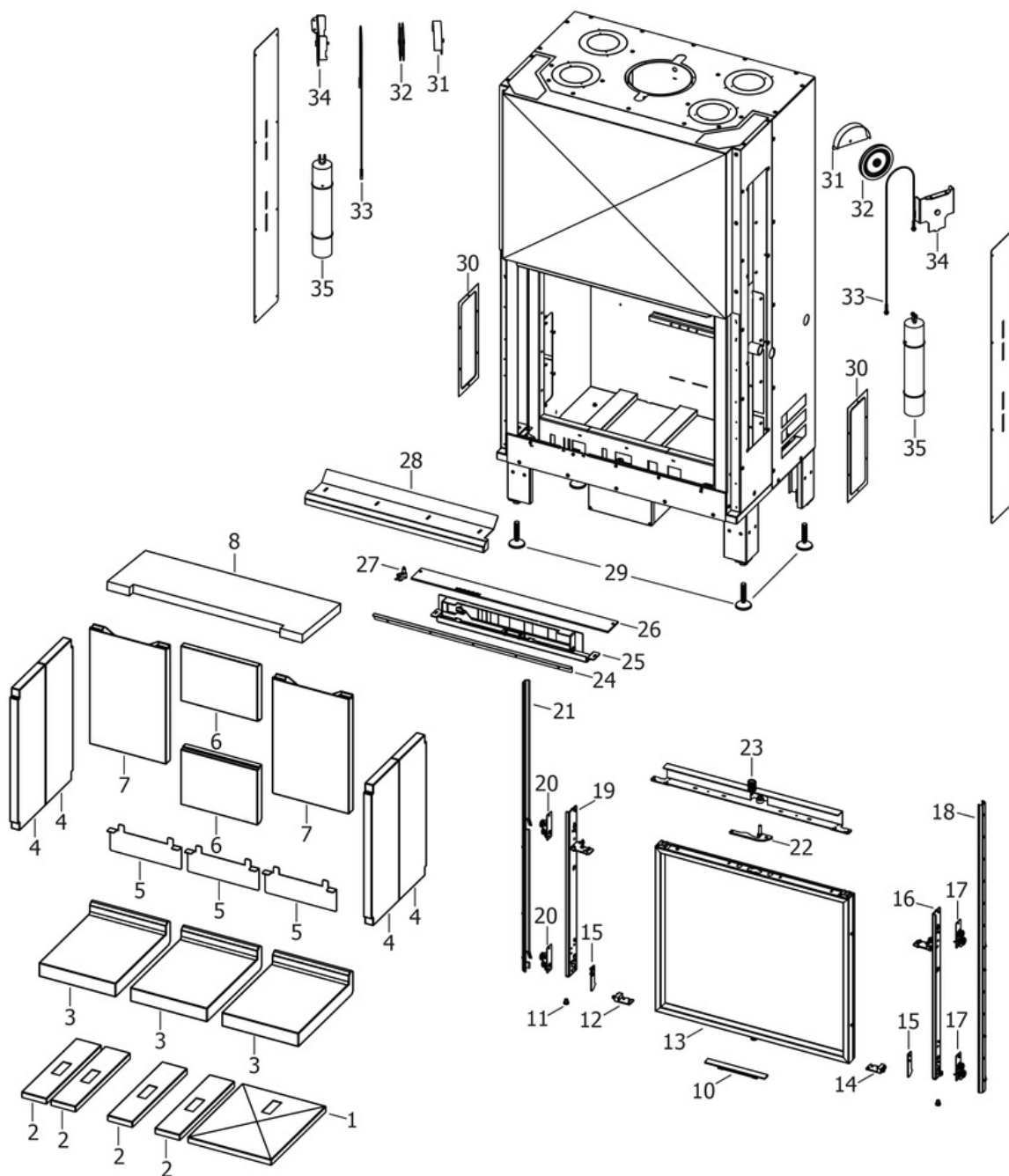

N°	Codice/Code	Descrizioni / Description / Beschreibung / Description / Descripcion
1	41401704730	Supporto Alutec 300 / Alutec 300 bracket / Alutec 300 Gestell / Support Alutec 300 / Soporte Alutec 300
2	41401704630	Supporto Alutec 90 / Alutec 90 bracket / Alutec 90 Gestell / Support Alutec 90 / Soporte Alutec 90
2	41401704630	Supporto Alutec 90 / Alutec 90 bracket / Alutec 90 Gestell / Support Alutec 90 / Soporte Alutec 90
2	41401704630	Supporto Alutec 90 / Alutec 90 bracket / Alutec 90 Gestell / Support Alutec 90 / Soporte Alutec 90
2	41401704630	Supporto Alutec 90 / Alutec 90 bracket / Alutec 90 Gestell / Support Alutec 90 / Soporte Alutec 90

3	42050281	Piano fuoco in Alutec / Alutec fire bed / Brennebene aus Alutec / Plaque foyère en Alutec / Piso del hogar en Alutec
3	42050281	Piano fuoco in Alutec / Alutec fire bed / Brennebene aus Alutec / Plaque foyère en Alutec / Piso del hogar en Alutec
3	42050281	Piano fuoco in Alutec / Alutec fire bed / Brennebene aus Alutec / Plaque foyère en Alutec / Piso del hogar en Alutec
4	41151704900	Laterale in Alutec / Lateral alutec / Seitliches aus Alutec / Latérale en Alutec / Lateral en Alutec
4	41151704900	Laterale in Alutec / Lateral alutec / Seitliches aus Alutec / Latérale en Alutec / Lateral en Alutec
4	41151704900	Laterale in Alutec / Lateral alutec / Seitliches aus Alutec / Latérale en Alutec / Lateral en Alutec
4	41151704900	Laterale in Alutec / Lateral alutec / Seitliches aus Alutec / Latérale en Alutec / Lateral en Alutec
5	41400935430	Staffa Alutec (1 pz.) / Staffa Alutec (1 pz.) / Staffa Alutec (1 pz.) / Staffa Alutec (1 pz.) / Staffa Alutec (1 pz.)
5	41400935430	Staffa Alutec (1 pz.) / Staffa Alutec (1 pz.) / Staffa Alutec (1 pz.) / Staffa Alutec (1 pz.) / Staffa Alutec (1 pz.)
5	41400935430	Staffa Alutec (1 pz.) / Staffa Alutec (1 pz.) / Staffa Alutec (1 pz.) / Staffa Alutec (1 pz.) / Staffa Alutec (1 pz.)
6	41151700400	Centrale in Alutec® / Alutec® central / Zentral aus Alutec® / Centrale en Alutec® / Parte central en Alutec®
6	41151700400	Centrale in Alutec® / Alutec® central / Zentral aus Alutec® / Centrale en Alutec® / Parte central en Alutec®
7	42050282	Schiena in Alutec / Alutec back / Rückwand aus Alutec / Fond en Alutec / Parte trasera en Alutec
7	42050282	Schiena in Alutec / Alutec back / Rückwand aus Alutec / Fond en Alutec / Parte trasera en Alutec
8	41151700800	Pannello Vermiculite / Vermiculite panel / Paneel aus Vermiculite / Panneau vermiculite / Panel en Vermiculite
10	41411722140P	Maniglia / Handle / Griff / Poignée / Tirador
11	4120180	Gommini paracolpi (4 pz) / Rubber bumpers (4 pcs.) / Schlagschutzgummi (4 Stck) / Pièces caoutchouc antichoc (4 pcs) / Cauchitos anti-golpes (4 pz)
12	41411721860	Cerniera SX zincata nera / L. galvanized black hinge / Li. Verzinkte schwarze Scharnier / G. Charnière galvanisé noir / Bisagra IZDA galvanizada negra
13	41421707250	Porta preassemblata plasma 95 / Preassembled door plasma 95 / Vormontierte Tür plasma 95 / Porte prémonté plasma 95 / Puerta preensablada plasma 95
14	41411722060	Cerniera DX zincata nera / R. galvanized black hinge / Re. Verzinkte schwarze Scharnier / D. Charnière galvanisé noir / Bisagra DCHA galvanizada negra
15	41411721110V	Blocco porta / Door stop / Türstopper / Stop pour porte / Tope por puerta
15	41411721110V	Blocco porta / Door stop / Türstopper / Stop pour porte / Tope por puerta
16	41411719740V	Spalla guida DX / R. Pillar / Re. Säule / Pilier D. / Pilar DCHO
17	41801703250	Carrello completo DX / Complete right trolley / Komplette rechte Wagen / Roulante complète droit / Carrito completo derecho
17	41801703250	Carrello completo DX / Complete right trolley / Komplette rechte Wagen / Roulante complète droit / Carrito completo derecho
18	41801702900	Guida LAN30K / Slider LAN30K / Schiene LAN30K / Glissière LAN30K / Guia LAN30K
19	41411719840V	Spalla guida SX / L. Pillar / Li. Säule / Pilier G. / Pilar IZDO
20	41801703350	Carrello completo SX / Complete left trolley / Komplette linke Wagen / Roulante complète gauche / Carrito completo izquierdo
20	41801703350	Carrello completo SX / Complete left trolley / Komplette linke Wagen / Roulante complète gauche / Carrito completo izquierdo
21	41801703000	Guida LAN30K / Slider LAN30K / Schiene LAN30K / Glissière LAN30K / Guia LAN30K
22	41411720640V	Maniglia chiusura / Closing handle / Griffschliessung / Poignée fermeture / Tirador de cierre
23	41411720540V	Slitta orizzontale / Horizontal slider / Horizontale Schiene / Glissière horizontale / Corredera horizontal
24	42041114	Profilo copribordo / Profile / Profil / Profil / Perfil
25	437017063	Gruppo registro / Register group / Register Gruppe / Group registre / Grupo registro
26	41411719511P	Base superiore nera / Black upper base / Schwarze obere Basis / Base supérieur noir / Base superior negra
27	414508020	Cablaggio switch / Switch cable / Switch Kabel / Câble switch / Switch cable
27	4160457	Pulsante per l'interruzione dell'alimentazione elettrica / power supply on-off button / Taste zur Unterbrechung der Stromversorgung / Bouton d'arrêt de l'alimentation électrique / Botón de corte de la alimentación eléctrica
28	41411719441V	Deflettore pulizia vetro / Deflector for glass cleaning / Leitblech für Glassreinigung / Deflecteur pour nettoyage du verre / Deflector por limpieza vidrio
29	412008041	Piedini di appoggio (4 pz.) / Support feet (4 pcs.) / Einstellfüße (4 Stck.) / Vérins d'appui (4 p.es) / Pies de apoyo (4 piezas)
30	41401703300	Tappo struttura / Structure plug / Strukturklappe / Clapet de la structure / Tapón estructura
30	41401703300	Tappo struttura / Structure plug / Strukturklappe / Clapet de la structure / Tapón estructura
31	41201007600	Gruppo carrucola / Pulley assembly / Seilzuggruppe / Groupe poulie / Grupo garrucha
31	41201007600	Gruppo carrucola / Pulley assembly / Seilzuggruppe / Groupe poulie / Grupo garrucha
32	412008004	Gruppo carrucola / Pulley assembly / Seilzuggruppe / Groupe poulie / Grupo garrucha

32	412008004	Gruppo carrucola / Pulley assembly / Seilzuggruppe / Groupe poulie / Grupo garrucha
33	412008019	Tirante fune / Steel anchor cable / Seilspannstange / Tirant câble en acier / Tirante sogá
33	412008019	Tirante fune / Steel anchor cable / Seilspannstange / Tirant câble en acier / Tirante sogá
34	41411720440V	Supporto carrucola / Pulley support / Haltebügel für Seilzuggruppe / Support poulie / Soporte garrucha
34	41411720440V	Supporto carrucola / Pulley support / Haltebügel für Seilzuggruppe / Support poulie / Soporte garrucha
35	42030615	Contrappeso 7,5 Kg. / Counterweight 7,5 Kg. / Gegengewicht 7,5 kg / Contrepoids 7,5 Kg. / Contrapeso 7,5 Kg
35	42030615	Contrappeso 7,5 Kg. / Counterweight 7,5 Kg. / Gegengewicht 7,5 kg / Contrepoids 7,5 Kg. / Contrapeso 7,5 Kg

PLASMA 95 WOOD

Porta fuoco / Fire door / Feuertür / Porte foyer / Puerta hogar

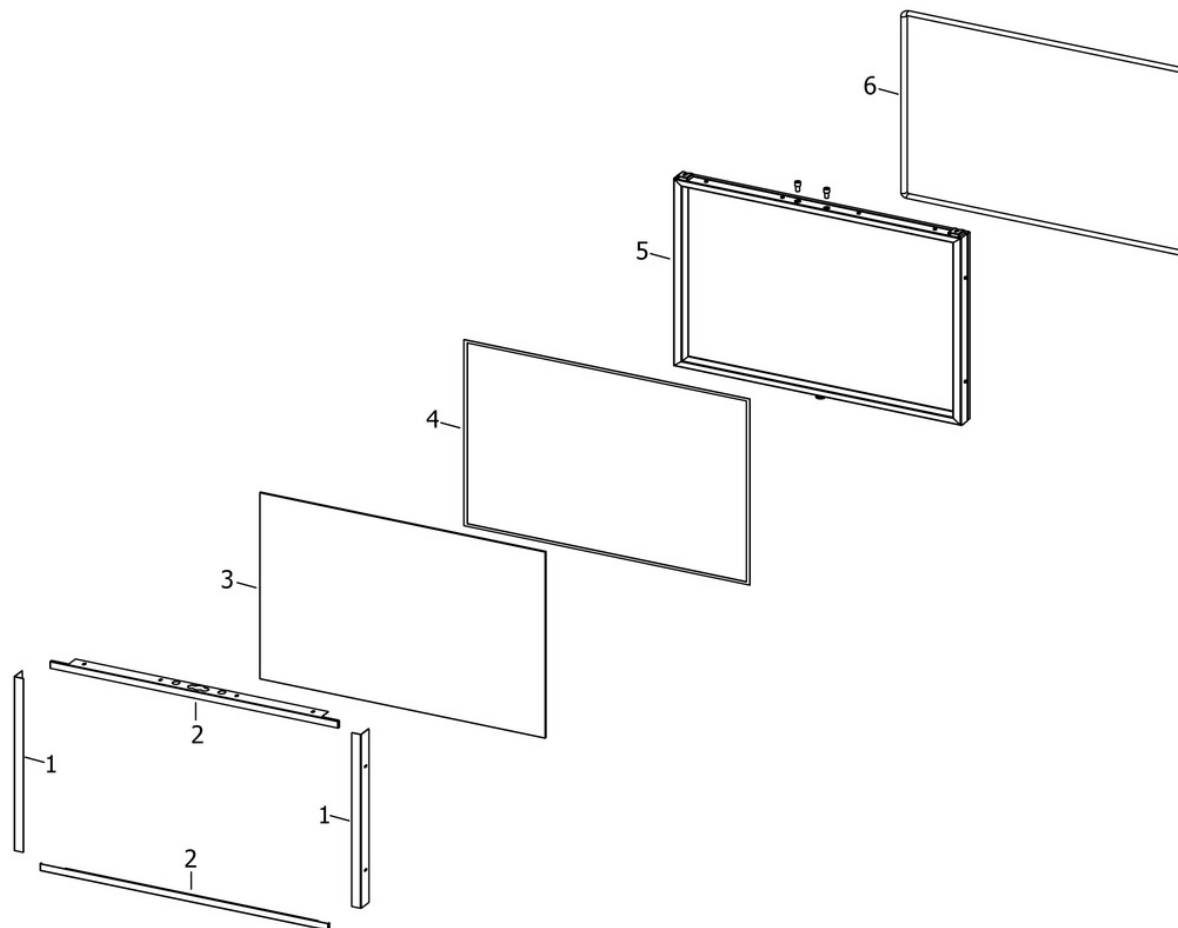

N°	Codice/Code	Descrizioni / Description / Beschreibung / Description / Description
1	4141172163000	Fermavetro porta nero / Black door guard glass / Schwarze Haltebügel für Tür-Scheibebefestigung / Patte de fixation porte noir / Fermacristal puerta negro
1	4141172163000	Fermavetro porta nero / Black door guard glass / Schwarze Haltebügel für Tür-Scheibebefestigung / Patte de fixation porte noir / Fermacristal puerta negro
2	4141172173000	Fermavetro laterale porta / Side door guard glass / Haltebügel für Seitentür-Scheibebefestigung / Patte de fixation porte lateral / Fermacristal puerta lateral
2	4141172173000	Fermavetro laterale porta / Side door guard glass / Haltebügel für Seitentür-Scheibebefestigung / Patte de fixation porte lateral / Fermacristal puerta lateral
3	41701700600	Vetroceramico 884x447x4 / Glass 884x447x4 / Glasskeramikscheibe 884x447x4 / Vitrocéramique 884x447x4 / Cristal cerámico 884x447x4
4	4120573A	Guarnizione a nastro 8 mm (5 mt.) per porta / Door strip gasket 8 mm (5 m) / Türbanddichtung 8 mm (5 m) / Joint ruban 8 mm (5 m) pour porte / Guarnición de cinta para puerta 8 mm (5 m)
4	4120573B	Guarnizione a nastro 8 mm (50 mt.) per porta / Door strip gasket 8 mm (50 m) / Türbanddichtung 8 mm (50 m) / Joint ruban 8 mm (50 m) pour porte / Guarnición de cinta para puerta 8 mm (50 m)
5	41411721240V	Porta plasma 95 / Door plasma 95 / Tür plasma 95 / Porte plasma 95 / Puerta plasma 95

6	41201704400A	Guarnizione Tricotex (5 mt) / Tricotex gasket (5 mt) / Dichtung Tricotex (5 mt) / Joint Tricotex (5 mt) / Junta Tricotex (5 mt)
6	41201704400B	Guarnizione Tricotex (50 mt) / Tricotex gasket (50 mt) / Dichtung Tricotex (50 mt) / Joint Tricotex (50 mt) / Junta Tricotex (50 mt)
6	41201704400C	Guarnizione Tricotex + silicone (5 mt) / Tricotex gasket + silicone (5 mt) / Dichtung Tricotex + Silikon (5 mt) / Joint Tricotex + silicone (5 mt) / Junta Tricotex + silicona (5 mt)