

AIKE COMFORT AIR 8 M1

Gruppo estetico / Aesthetic group / Aesthetische Gruppe / Groupe esthétique / Grupo estético

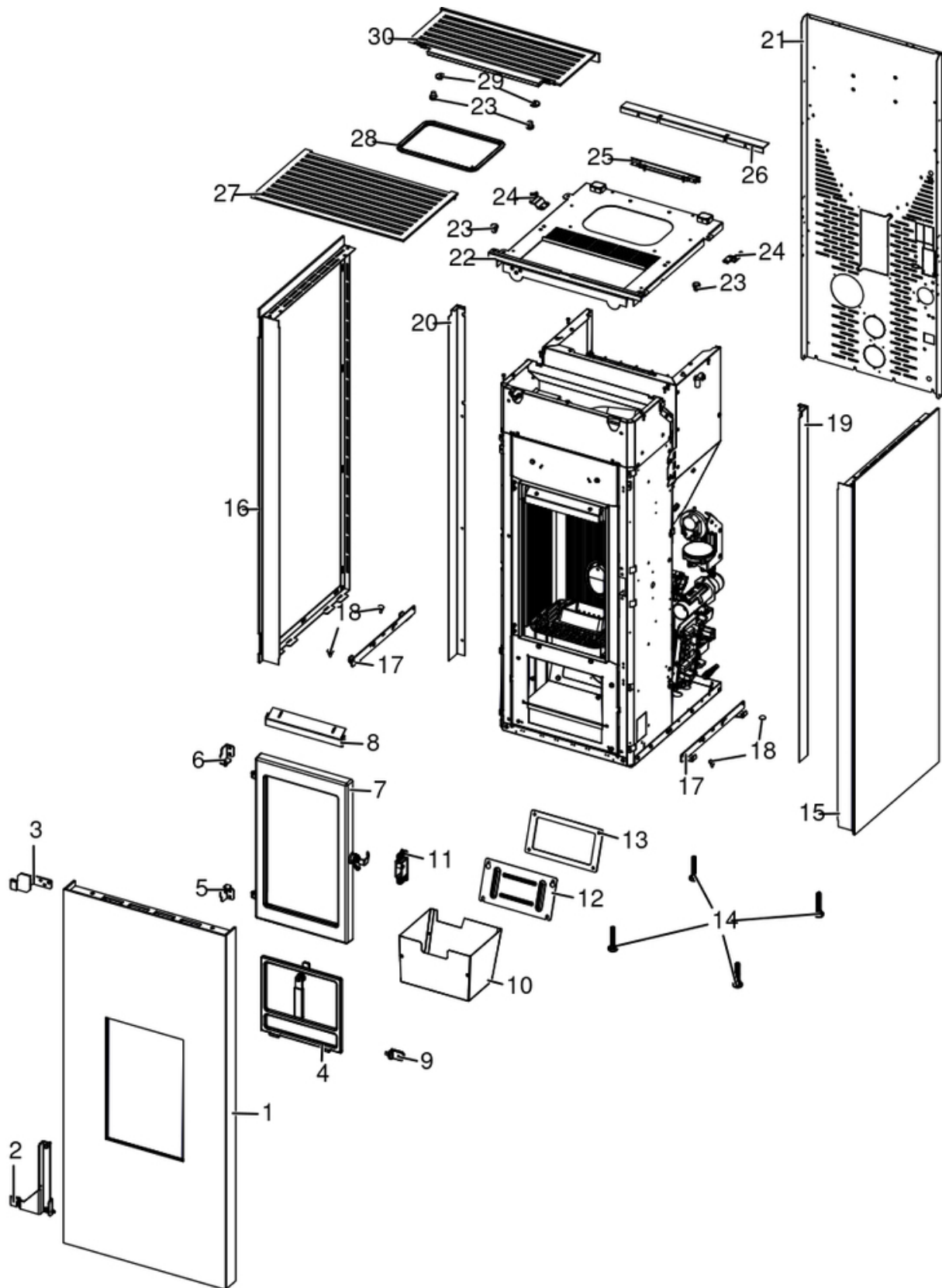

N°	Codice/Code	Descrizioni / Description / Beschreibung / Description / Descripcion
1	41421708550	Porta estetica / Aesthetic door / Außentür / Porte esthétique / Puerta estética
2	41411664540V	Cerniera inferiore / Lower hinge / Unteres Scharnier / Charnière inférieur / Bisagra inferior
3	41411664640V	Cerniera superiore / Upper hinge / Oberes Scharnier / Charnière supérieur / Bisagra superior
4	437016130	Porta cenere con maniglia / Ash drawer door with handle / Tür des Aschenkastens mit Griff / Porte tiroir à cendres avec poignée / Puerta cajón ceniza con tirador
5	41411738040V	Cerniera inf.porta ghisa / Lower hinge for cast iron door / Unterer Scharnier für Tür aus Guß / Charnière inférieure pour porte en fonte / Bisagra inferior por porta en arrabio
6	41411738140V	Cerniera sup.porta ghisa / Upper hinge for cast iron door / Obere Scharnier für Tür aus Guß / Charnière supérieur pour porte en fonte / Bisagra superior por porta en arrabio
7	437017082	Porta fuoco in ghisa / Cast iron fireplace door / Feuertür aus Gusseisen / Porte foyer en fonte / Puerta hogar de arrabio
8	41411615430V	Deflettore aria / Air deflector / Luftleitblech / Déflecteur aire / Deflector aire
9	41411623740V	Cerniera acciaio porta cenere / Ash compartment door steel hinge / Aschenklappe Stahlscharnier / Charnier en acier porte compartiment cendre / Bisagra en acero puerta compartimento cenizas
10	437016041	Cassetto cenere / Ash drawer / Aschenkasten / Tiroir à cendres / Cajón ceniza
11	41411599950	Kit serratura ammortizzato / Pressur relief kit / Bausatz Überdruckablauf Brennkammer / Kit deocompression chambre comcusion / Kit decompression cámara combustion
12	41401339610	Tappo ispezione vano fumi / Smoke compartment inspection plug / Inspektionsdeckel Rauchabzug / Clapet inspection compartiment fumées / Tapón inspección compartimento humos
13	41800900600	Guarnizione / Gasket / Dichtung / Joint / Junta
14	41200906660	Piedini di appoggio (4 pz.) / Support feet (4 pcs.) / Einstellfüße (4 Stck.) / Vérins d'appui (4 p.es) / Pies de apoyo (4 piezas)
15	41421606140P	Fianco destro nero / Black right side / Schwarze rechte Seite / Coté droit noir / Lateral derecho negro
16	41421606240P	Fianco sinistro nero / Black left side / Schwarze linke Seite / Coté gauche noir / Lateral izquierdo negro
17	4141166483000	Aggancio inferiore fianco / Lower bracket for side / Untere Halterung für Seite / étrier inférieur coté / Soporte inferior lado
18	41801002300	Paracolpi in silicone Ø 8/5 (2pz) / Silicone bumpers Ø 8/5 (2pcs) / Schlagschutzgummi Ø 8/5 (2 Stck) / Pièces silicone antichoc Ø 8/5 (2pcs) / Anti-golpes en silicona Ø 8/5 (2pzs)
19	4141166613100	Cornice posteriore destra / Rear right frame / Rechter seitliche Rahmen / Encadrement posterieur droite / Marco posterior derecho
20	4141166623100	Cornice posteriore sinistra / Rear left frame / Linker seitliche Rahmen / Encadrement posterieur gauche / Marco posterior izquierdo
21	41401624337	Schiava serbatoio c/supporto scheda / Rear back with mother board support / Rückwand mit Platine Halterung / Dos du réservoir avec support carte mère / Espalda de depósito con soporte tarjeta
22	4142160604200	Supporto top / Top support / Deckel Haltebügel / Support dessus / Soporte del top
23	4120180	Gommini paracolpi (4 pz) / Rubber bumpers (4 pcs.) / Schlagschutzgummi (4 Stck) / Pièces caoutchouc antichoc (4 pcs) / Cauchitos anti-golpes (4 pz)
24	4141166553000	Supporto cerniera / Hinge support / Halterung Scharnier / Support charnière / Soporte bisagra
25	4141166563000	Cerniera coperchio serbatoio / Pellet hopper hinge / Scharnier Pelletbehälter / Charnière couvercle réservoir / Bisagra tapadera depósito
26	4141166633100	Cornice superiore / Upper frame / Oberblende / Encadrement supérieur / Marco superior
27	41421500750	Griglia aria / Air outlet grille / Warmluftgitter / Grille air chaud / Rejilla salida aire
28	41801504700	Guarnizione tenuta serbatoio / Pellet hopper gasket / Pelletbehälter Dichtung / Joint réservoir pellet / Junta depósito pellet
29	41801657900	Magneti (pz.2) / Magnet (pcs.2) / Magnet (stk. 2) / Aimant (pcs.2) / Imán (pz.2)
30	41421606350	Coperchio serbatoio / Hopper cover / Deckel Pelletbehälter / Couvercle réservoir / Tapa depósito

AIKE COMFORT AIR 8 M1

Porta fuoco / Fire door / Feuertür / Porte foyer / Puerta hogar

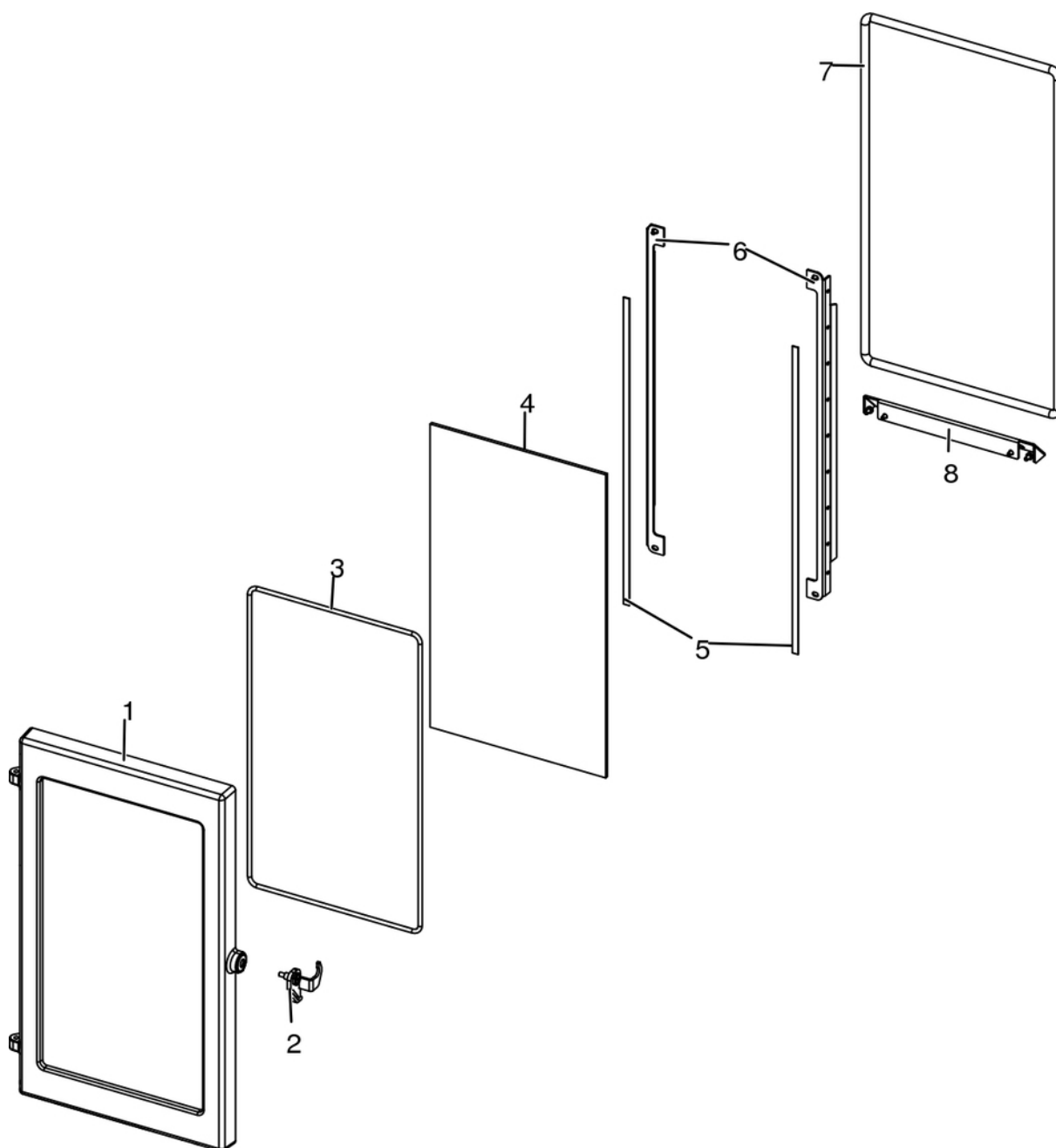

N°	Codice/Code	Descrizioni / Description / Beschreibung / Description / Description
1	41301602500V	Telaio porta fuoco / Fire door frame / Feuertürrahmen / Cadre foyer / Armazón puerta de arrabio
2	41411616560	Maniglia porta nera / Door Handle / Türgriff / Poignée porte / Tirador
3	41801603300A	Guarnizione Ø5 5mt / Gasket Ø5 5mt / Dichtung Ø5 5mt / Joint Ø5 5mt / Junta Ø5 5mt
3	41801603300B	Guarnizione Ø5 50mt / Gasket Ø5 50mt / Dichtung Ø5 50mt / Joint Ø5 50mt / Junta Ø5 50mt
3	41801603300C	Guarnizione Ø5 5mt + silicone / Gasket Ø5 5mt + silic / Dichtung Ø5 5mt + Silikon / Joint Ø5 5mt + silic / Junta Ø5 5mt
4	41701600300	Vetroceramico porta ghisa / Cast iron door glass / Glaskeramikscheibe Tür aus Gusseise / Vitrocéremique porte en fonte / Cristal cerámico puerta en arrabio
5	4120573A	Guarnizione a nastro 8 mm (5 mt.) per porta / Door strip gasket 8 mm (5 m) / Türbanddichtung 8 mm (5 m) / Joint ruban 8 mm (5 m) pour porte / Guarnición de cinta para puerta 8 mm (5 m)
5	4120573B	Guarnizione a nastro 8 mm (50 mt.) per porta / Door strip gasket 8 mm (50 m) / Türbanddichtung 8 mm (50 m) / Joint ruban 8 mm (50 m) pour porte / Guarnición de cinta para puerta 8 mm (50 m)

6	41411622030V	Profilo fermavetro / Fastening bracket profile / Haltebügel für Scheibebefestigung Profil / Profil patte de fixation / Perfil fermacristal
7	4120104A	Cordino fibroceramico Ø 12 mm (5 mt.) / Ceramic fibre cord Ø 12 mm (5 m.) / Keramikfaserschnur Ø 12 mm (5 m) / Cordon en fibre céramique Ø 12 mm (5 m) / Junta a cuerda de fibra cerámica Ø 12 mm (5 m)
7	4120104B	Cordino fibroceramico Ø 12 mm (50 mt.) / Ceramic fibre cord Ø 12 mm (50 m.) / Keramikfaserschnur Ø 12 mm (50 m) / Cordon en fibre céramique Ø 12 mm (50 m) / Junta a cuerda de fibra cerámica Ø 10 mm (52 m)
7	41201041	Kit sostituzione cordino (cordino+silicone) Ø 12 mm / Cord replacement kit (cord + silicon) Ø 12 mm / Schnuraustauschsatz (Schnur+Silikon) Ø 12 mm / Kit remplacement cordon (cordon + silicone) Ø 12 mm / Kit sustitución junta a cuerda (junta a cuerda+silicón) Ø 12 mm
8	41411622130V	Scivolo cenere / Ash ramp / Aschenrutsche / Glissière cendre / Tobogán ceniza

AIKE COMFORT AIR 8 M1

Gruppo camera di combustione / Combustion chamber group / Verbrennungskammer Gruppe / Group de chambre de combustion / Grupo cámara de combustión

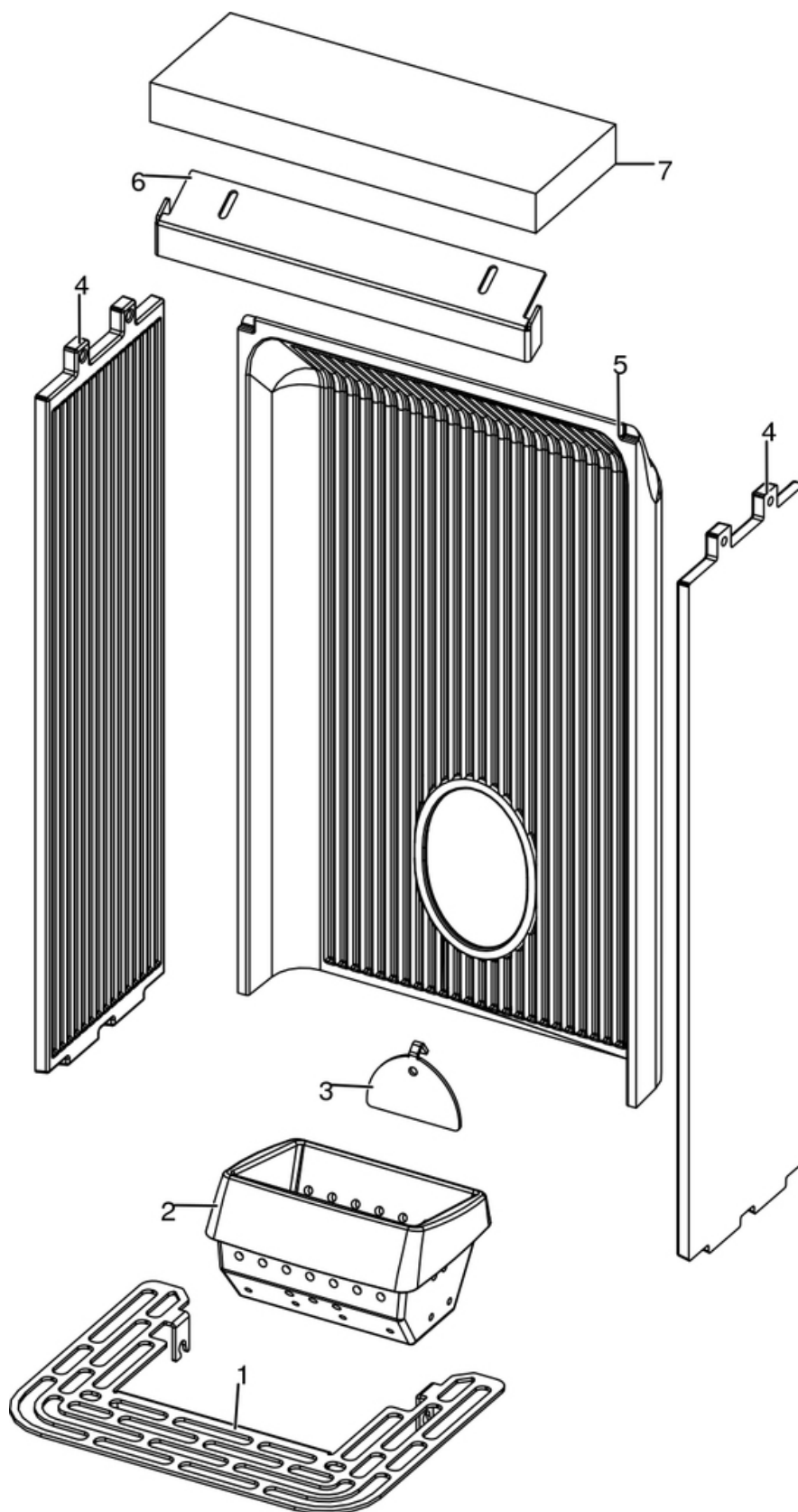

N°	Codice/Code	Descrizioni / Description / Beschreibung / Description / Descripcion
1	41411634830V	Griglia focolare / Fire Box Grille / Feuerstellenrost / Grille Foyer / Rejilla Hogar
2	41301502400V	Braciere ghisa / Cast iron grate / Brennertopf aus Gusseisen / Brasero en fonte / Brasero en arrabio
3	41411613530V	Deflettore pellet / Pellet deflector / Pellet Leitblech / Deflecteur pellet / Deflector pellet
4	41301502500V	Fianco ghisa / Cast iron side / Seite aus Guß / Côté en fonte / Placa lateral de arrabio
5	41301502600V	Schiena ghisa / Cast iron back / Rückwand aus Gusseisen / Dossieret en fonte / Parte trasera en arrabio
6	41411615430V	Deflettore aria / Air deflector / Luftleitblech / Déflecteur aire / Deflector aire
7	41151600200	Deflettore focolare in vermiculite / Vermiculite deflector / Leitblech aus Vermiculite / Déflecteur en vermiculite / Deflector en vermiculite

AIKE COMFORT AIR 8 M1

Gruppo accensione / Ignition group / Entzündung Gruppe / Groupe d'allumage / Grupo ignición

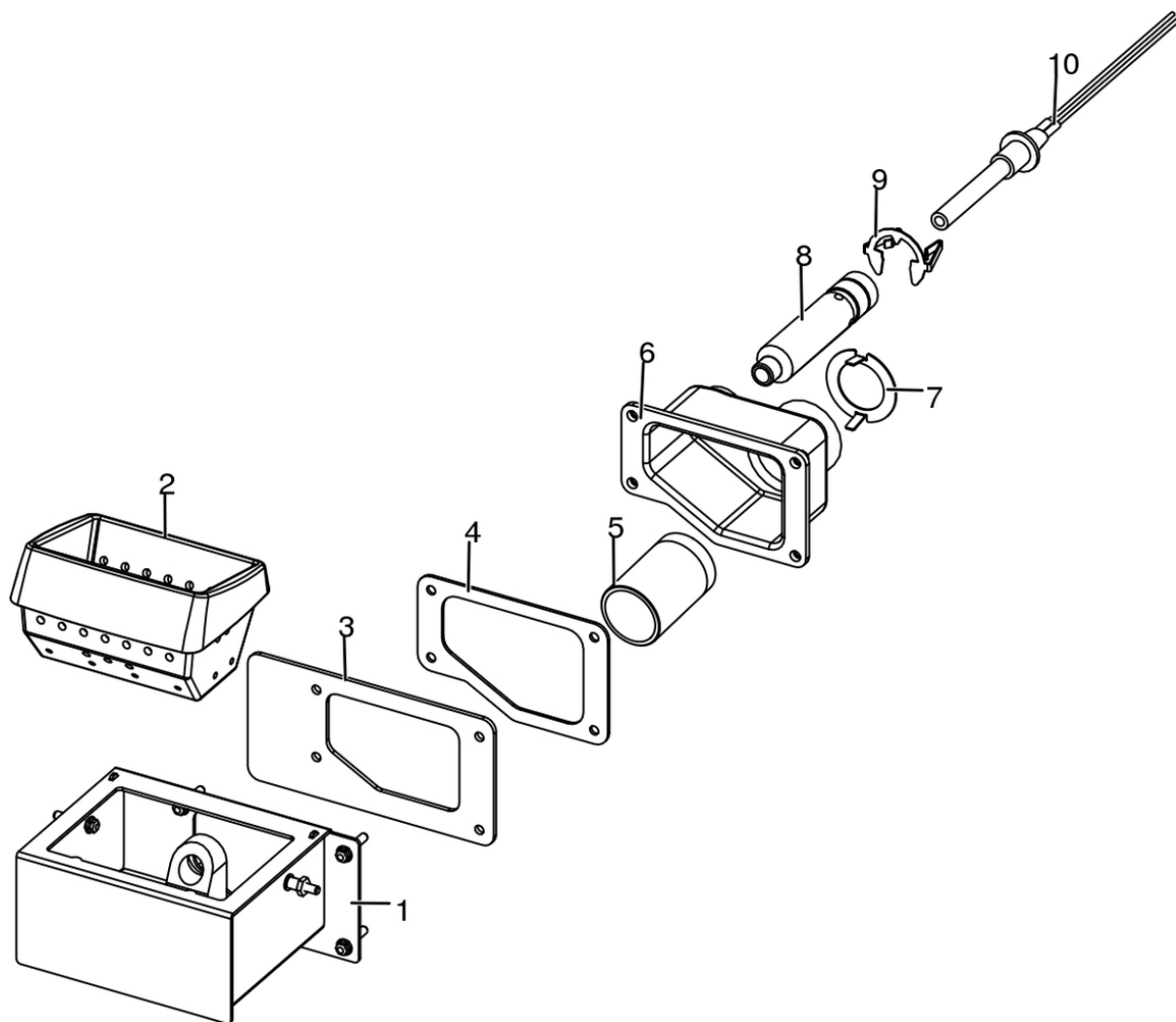

N°	Codice/Code	Descrizioni / Description / Beschreibung / Description / Descripción
1	41411613140V	Tasca braciere / Combustion pot container / Brenntopfkasten / Récipient brasero / Contenidor brasero
2	41301502400V	Braciere ghisa / Cast iron grate / Brennertopf aus Gusseisen / Brasero en fonte / Brasero en arrabio
3	41801601500	Guarnizione tasca braciere / Combustion pot container gasket / Brenntopfkasten Dichtung / Joint récipient brasero / Junta contenidor brasero
4	41801602300	Guarniziono codolo / Gasket / Dicktung / Joint / Junta
5	41501701599	Manicotto potenziamento accensione / Combustion air extension pipe / Zusatzrohr für Nachrüstung / Tuyau amélioration allumage / Tubo impulso de encendido
6	41311803500	Codolo / Tool chuck / Einspannschaft / Outil d'emmanchement / Mango
7	41401629410	Regolatore ingresso aria comburente / Combustion air intake adjuster / Regler Eingang Verbrennungsluft / Régulateur arrivée air comburant / Regulador entrada aire comburente
8	41601601000	Condotto candeletta / Sparkplug Conduit / Zündkerzenkanal / Conduit Bougie / Conducto Bujía
9	41201601500	Anello arresto candeletta / Sparkplug stop / Zündkerzestopper / Butée bougie / Tope bujía
10	41451308101	Candeletta 315 Watt / Sparkplug 315 Watt / Zündkerze 315 Watt / Bougie 315 Watt / Bujía 315 Watt
10	41451308150	Kit 25 candelette 315 Watt / 25 Sparkplugs 315 Watt kit / Bausatz 25 Zündkerzen 315 Watt / Kit 25 Bougies 315 Watt / Kit 25 Bujías 315 Watt

AIKE COMFORT AIR 8 M1

Porta estetica / Aesthetic door / Aesthetische Tür / Porte esthétique / Puerta estética

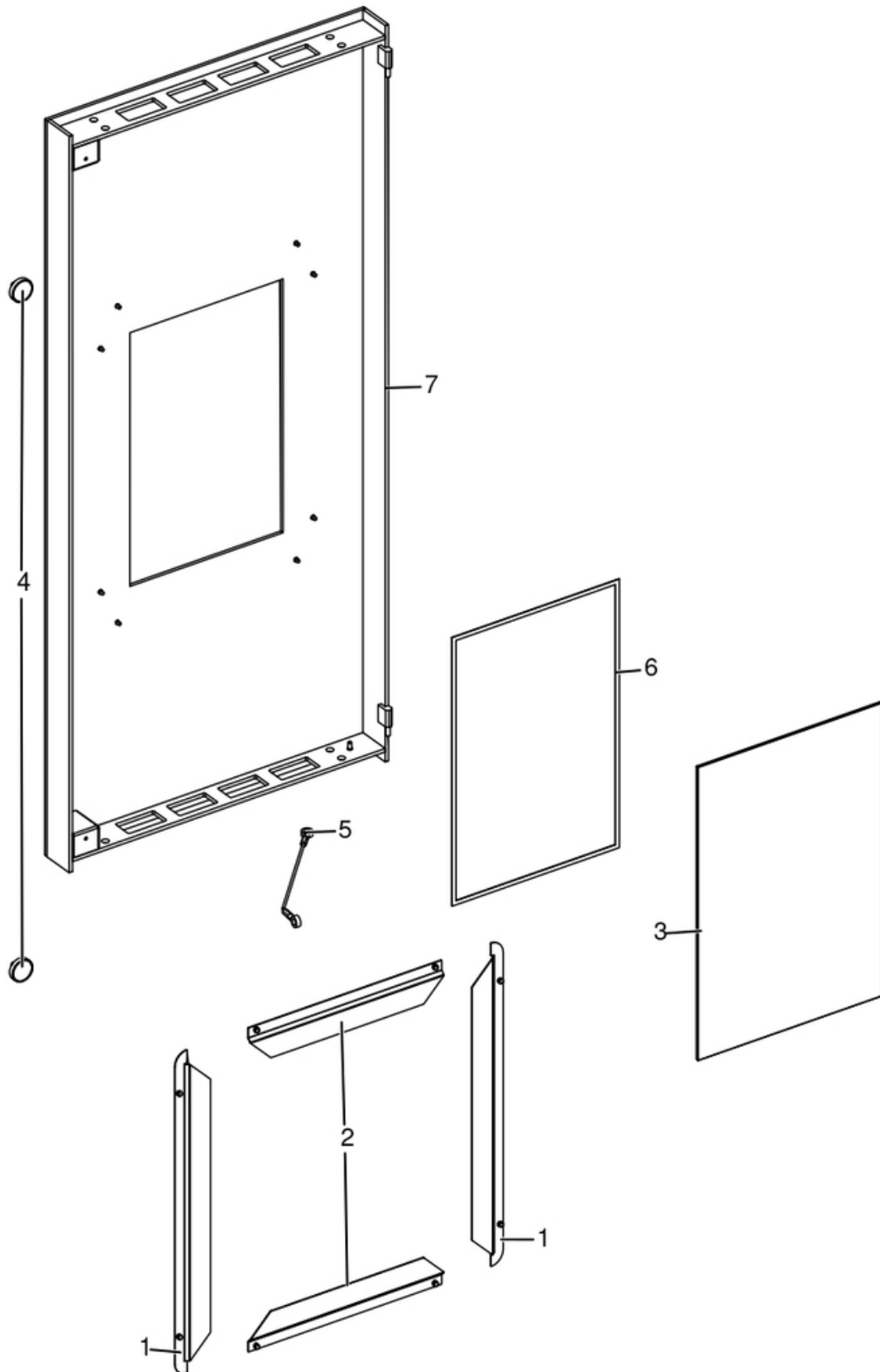

N°	Codice/Code	Descrizioni / Description / Beschreibung / Description / Descripción
1	41411663830V	Fermavetro laterale porta esterna / Lateral glass fastening bracket - External door / Seitenhaltebügel für Scheibebefestigung - Außentür / Etrier laterale de fixation vitrocéramique - porte extérieure / Retendor lateral del cristal - Puerta exterior
2	41411663730V	Fermavetro superiore/inferiore porta esterna / Superior/Inferior glass fastening bracket - External door / Obere/Untere haltebügel für Scheibebefestigung - Außentür / Etrier supérieur/inferieur de fixation vitrocéramique - porte extérieure / Retendor superior/inferior del cristal - Puerta exterior
3	41700900700	Vetroceramico completo di guarnizione / Glass with gasket / Glaskeramikscheibe mit Dichtung / Vitrocéramique avec joint / Cristal cerámico con guarnición
4	41801001500	Magnete / Magnet / Magnet / Aimant / Imán
5	41801501000	Cavo finecorsa / Limit switch cable / Endanschlagkabel / Câble de commutateur de limite / Cable del interruptor de límite
6	4120572A	Guarnizione a nastro 6 mm (5 mt.) per porta / Door strip gasket 6 mm (5 m) / Türbanddichtung 6 mm (5 m) / Joint ruban 6 mm (5 m) pour porte / Guarnición de cinta para puerta 6 mm (5 m)
6	4120572B	Guarnizione a nastro 6 mm (50 mt.) per porta / Door strip gasket 6 mm (50 m) / Türbanddichtung 6 mm (50 m) / Joint ruban 6 mm (50 m) pour porte / Guarnición de cinta para puerta 6 mm (50 m)
7	4142160594100	Porta estetica / Aesthetic door / Außentür / Porte esthétique / Puerta estética

AIKE COMFORT AIR 8 M1

Porta cenere / Ash door / Ashentür / Porte cendre / Puerta ceniza

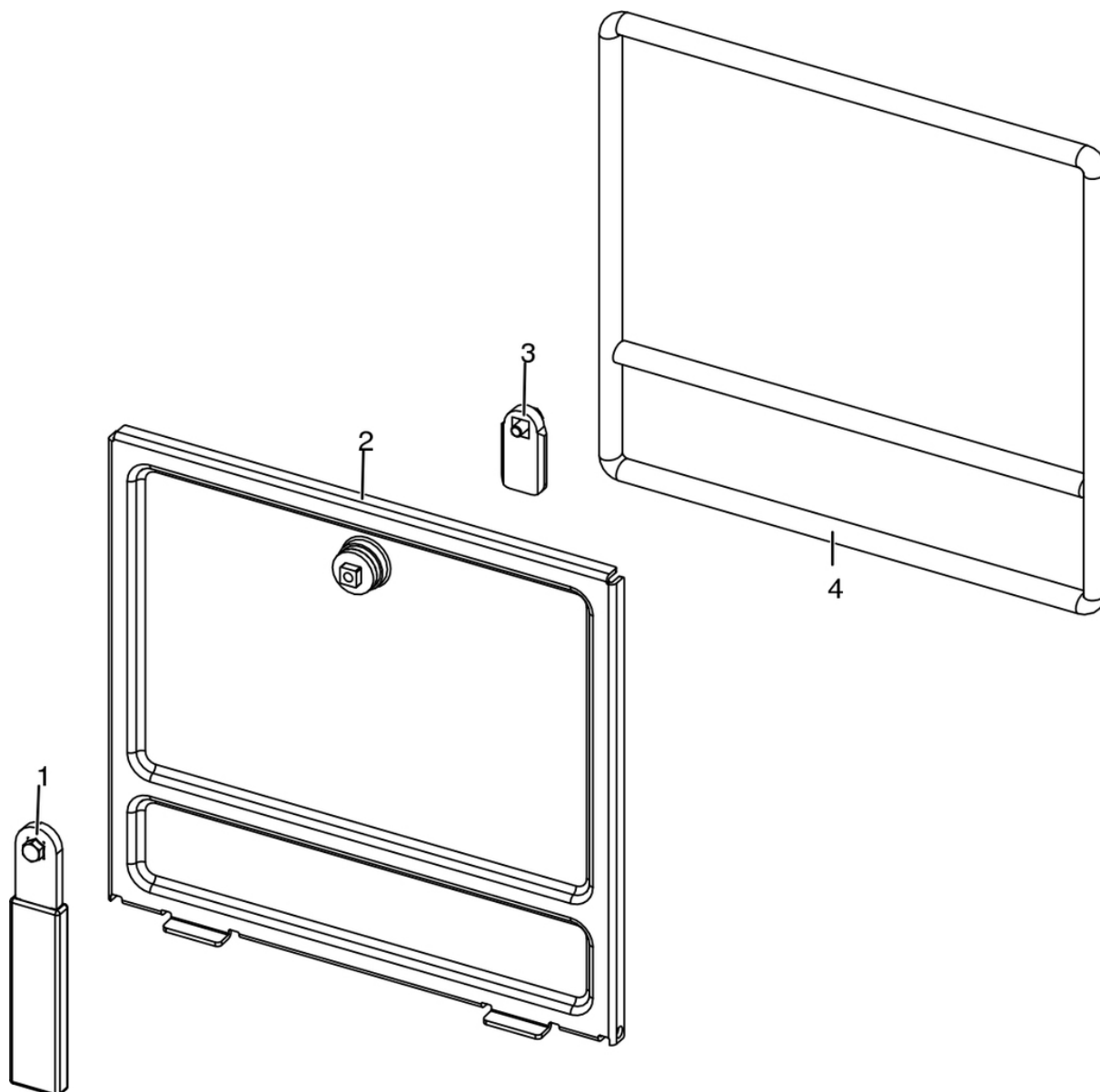

N°	Codice/Code	Descrizioni / Description / Beschreibung / Description / Descripción
1	41411621600	Maniglia con impugnatura porta cenere / Handle / Griff / Poignée / Tirador
2	41421602141V	Porta cenere / Ash drawer door / Tür des Aschenkastens / Porte tiroir à cendres / Puerta cajón ceniza
3	41201608400	Serratura porta cassetto cenere / Door lock for ash drawer / Türschloss für Aschenkasten / Serrure de porte du tiroir à cendres / Cerradura puerta cajón ceniza
4	412007003A	Cordino fibroceramico Ø 14 mm (5 mt.) / Ceramic fibre cord Ø 14 mm (5 m.) / Keramikfaserschnur Ø 14 mm (5 m) / Cordon en fibre céramique Ø 14 mm (5 m) / Junta a cuerda de fibra cerámica Ø 14 mm (5 m)
4	412007003B	Cordino fibroceramico Ø 14 mm (50 mt.) / Ceramic fibre cord Ø 14 mm (50 m.) / Keramikfaserschnur Ø 14 mm (50 m) / Cordon en fibre céramique Ø 14 mm (50 m) / Junta a cuerda de fibra cerámica Ø 14 mm (50 m)
4	412007003C	Kit sostituzione cordino (cordino+silicone) Ø 14 mm / Cord replacement kit (cord + silicon) Ø14 mm / Schnuraustauschsatz (Schnur +Silikon) Ø 14 mm / Kit remplacement cordon (cordon+silicon) Ø 14 / Kit sustitución junta a cuerda (junta a cuerda+silicón) Ø 14 mm

AIKE COMFORT AIR 8 M1

Gruppo caricamento pellet acciaio / Pellet feed group in steel / Pellet Fördergruppe aus Stahl / Groupe de chargement pellet en acier / Grupo de carga pellet acero

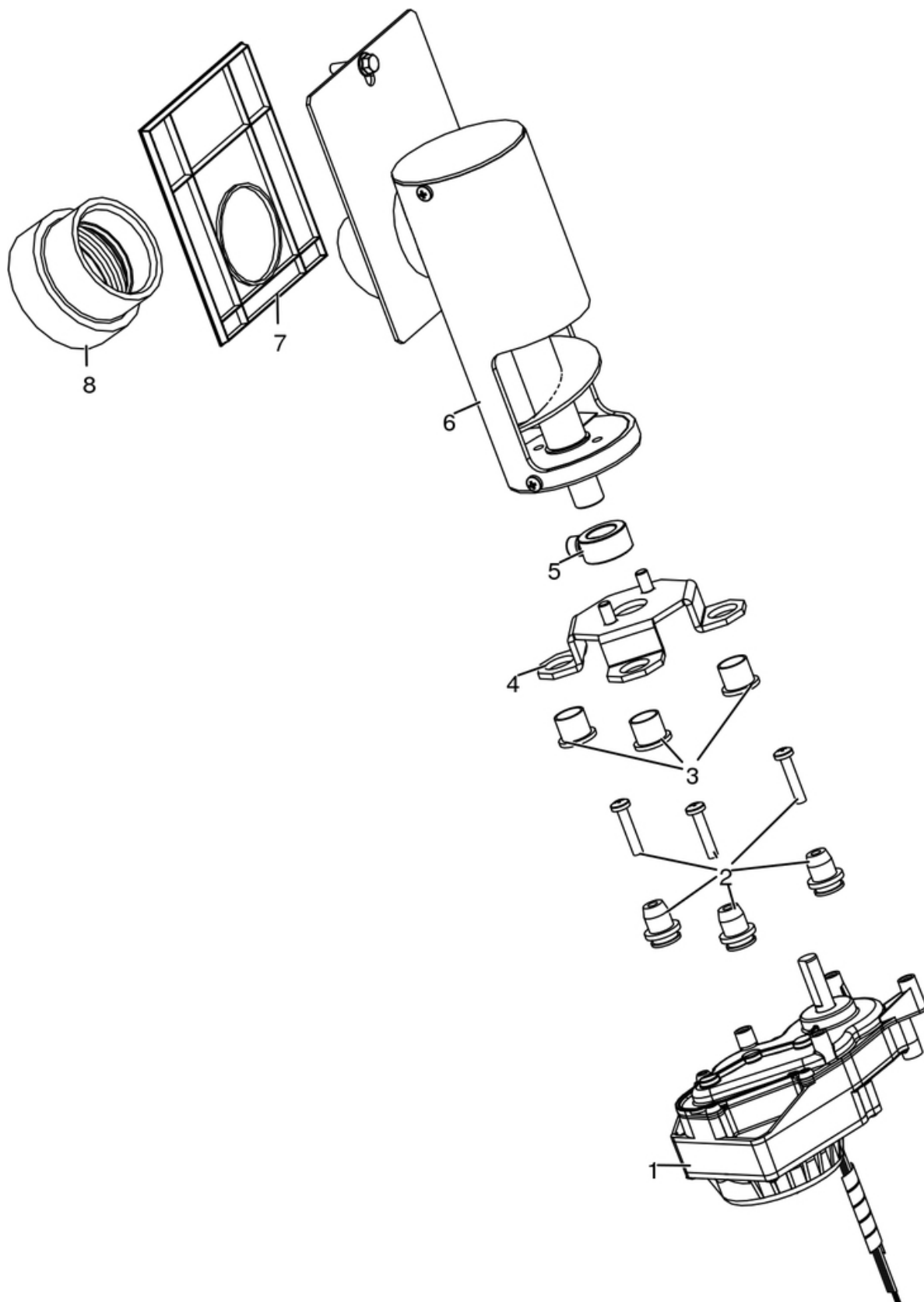

N°	Codice/Code	Descrizioni / Description / Beschreibung / Description / Descripción
1	41451702200	Motoriduttore brushless / Brushless reduction motor / Brushless Getriebemotor / Motoréducteur brushless / Motorreductor brushless
2	41801703700	Gommini antivibrante / Vibration damper rubber / Rammschutz Gummi / Caoutchouc antivibratoire / Cauchitos antivibración
3	41201800700	Boccola (3 pz) / Bushing (3 pcs) / Buchse (3 Stk) / Douille (3 pcs) / Abrazadera (3 pzs)
4	41411779331	Supporto coclea "Ragno" / Pellet feed screw bracket "spider" / "Spinne" Schenke Gestell / Support vis sans fin "Araignée" / Soporte coclea "Araña"
5	4120398	Connettore motoriduttore-coclea / Reduction motor-feed screw connector / Verbindung Getriebemotor-Schnecke / Connecteur motoréducteur-vis sans fin / Conector motorreductor-cóclea
6	41411800151	Gruppo alimentazione completo / Complete feed screw / Komplette Förderschnecke / Vis sans fin complète / Coclea de carga completa
7	41801600400	Guarnizione gruppo caricamento / Gasket / Dichtung / Joint / Junta
8	41801702600	Disaccoppiatore mesc. Marrone / Brown disengaging device / Braun Verängungsrohr / Tuyau de découplage maron / Tubo de desvío marron

AIKE COMFORT AIR 8 M1

Gruppo aria comburente / Combustion air group / Verbrennungsluft Gruppe / Groupe air comburant / Grupo aire comburente

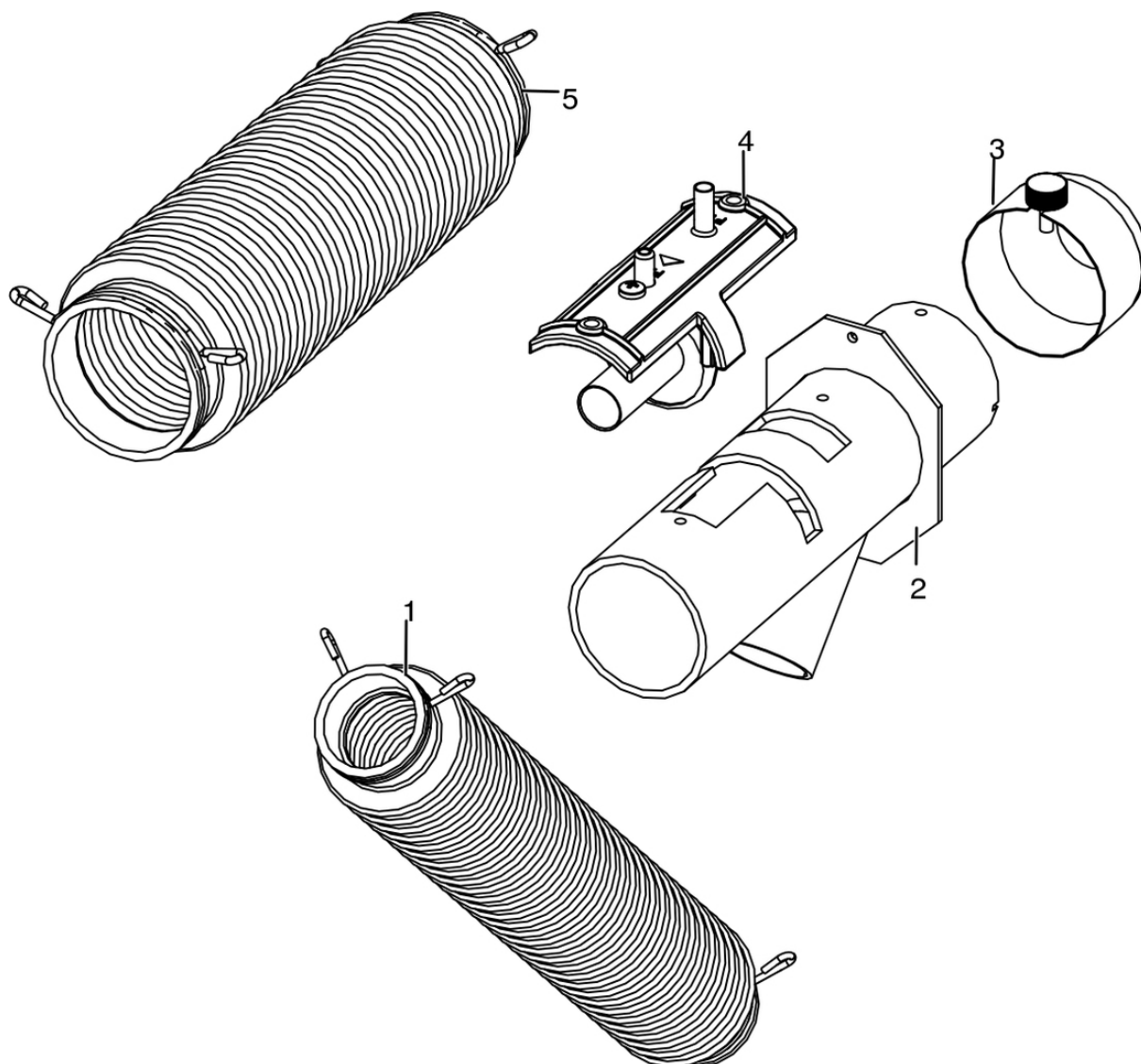

N°	Codice/Code	Descrizioni / Description / Beschreibung / Description / Descripción
1	41801601900	Tubo aspirazione pulizia vetro / Inlet pipe for cleaning glass air / Glassreinigungs Lufteingangsrohr / Tuyau entrée pour l'aire de nettoyage du vitre / Tubo entrada por l'aire de limpieza vidrio
2	41601604461	Tubo aspirazione / Air inlet pipe / Lufteingangsrohr / Tuyau entrée d'air / Tubo entrada aire
3	41401036100	Filtro antipolvere / Anti-dust filter / Staubschutzfilter / Filtre antipoussière / Filtro de protección polvo
4	41601301850	Componente rilevamento portata aria / Air flow measure component / Bauteil für Messung der Luftmenge / Composent pour la mesuration de la quantité d'air / Componente por la medida de l'aire
5	41801601700	Tubo aspirazione camera combustione / Combustion chamber aspiration tube / Verbrennungskammer Förderrohr / Tuyau aspiration air chambre de combustion / Tubo aspiración aire cámara de combustión

AIKE COMFORT AIR 8 M1

Gruppo caricamento pellet alluminio / Pellet feed group aluminium / Pellet Fördergruppe Aluminium /
Groupe de chargement pellet aluminium / Grupo de carga pellet aluminio

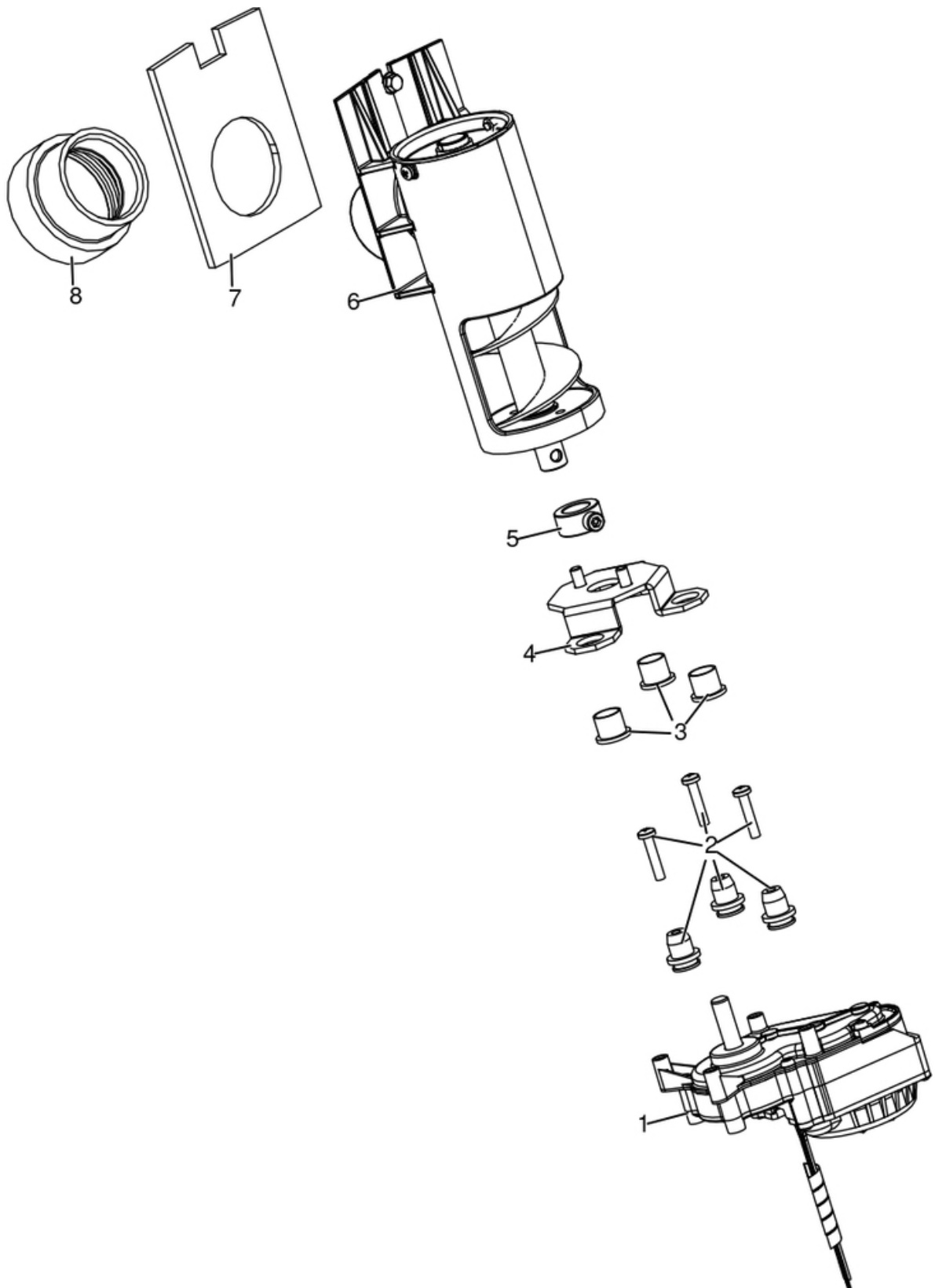

N°	Codice/Code	Descrizioni / Description / Beschreibung / Description / Descripción
1	41451702200	Motoriduttore brushless / Brushless reduction motor / Brushless Getriebemotor / Motoréducteur brushless / Motorreductor brushless
2	41801703700	Gommini antivibrante / Vibration damper rubber / Rammschutz Gummi / Caoutchouc antivibratoire / Cauchitos antivibración
3	41201800700	Boccola (3 pz) / Bushing (3 pcs) / Buchse (3 Stk) / Douille (3 pcs) / Abrazadera (3 pzs)
4	41411779331	Supporto coclea "Ragno" / Pellet feed screw bracket "spider" / "Spinne" Schenke Gestell / Support vis sans fin "Araignée" / Soporte coclea "Araña"
5	4120398	Connettore motoriduttore-coclea / Reduction motor-feed screw connector / Verbindung Getriebemotor-Schnecke / Connecteur motoréducteur-vis sans fin / Conector motorreductor-cóclea
6	41402002050	Gruppo alimentazione / Complete feed screw / Komplette Förderschnecke / Vis sans fin complète / Coclea de carga completa
7	41802000300	Guarnizione / Gasket / Dichtung / Joint / Junta
8	41801702600	Disaccoppiatore mesc. Marrone / Brown disengaging device / Braun Verängungsrohr / Tuyau de découplage maron / Tubo de desvío marron

AIKE COMFORT AIR 8 M1

Gruppo elettrico ed elettronico fino al SN 2104070030010 / Electrical and electronic group up to SN 2104070030010 / Elektrische und elektronische Gruppe bis zur SN 2104070030010 / Groupe électrique et électronique jusqu'au NS 2104070030010 / Grupo eléctrico y electrónico hasta NS 2104070030010

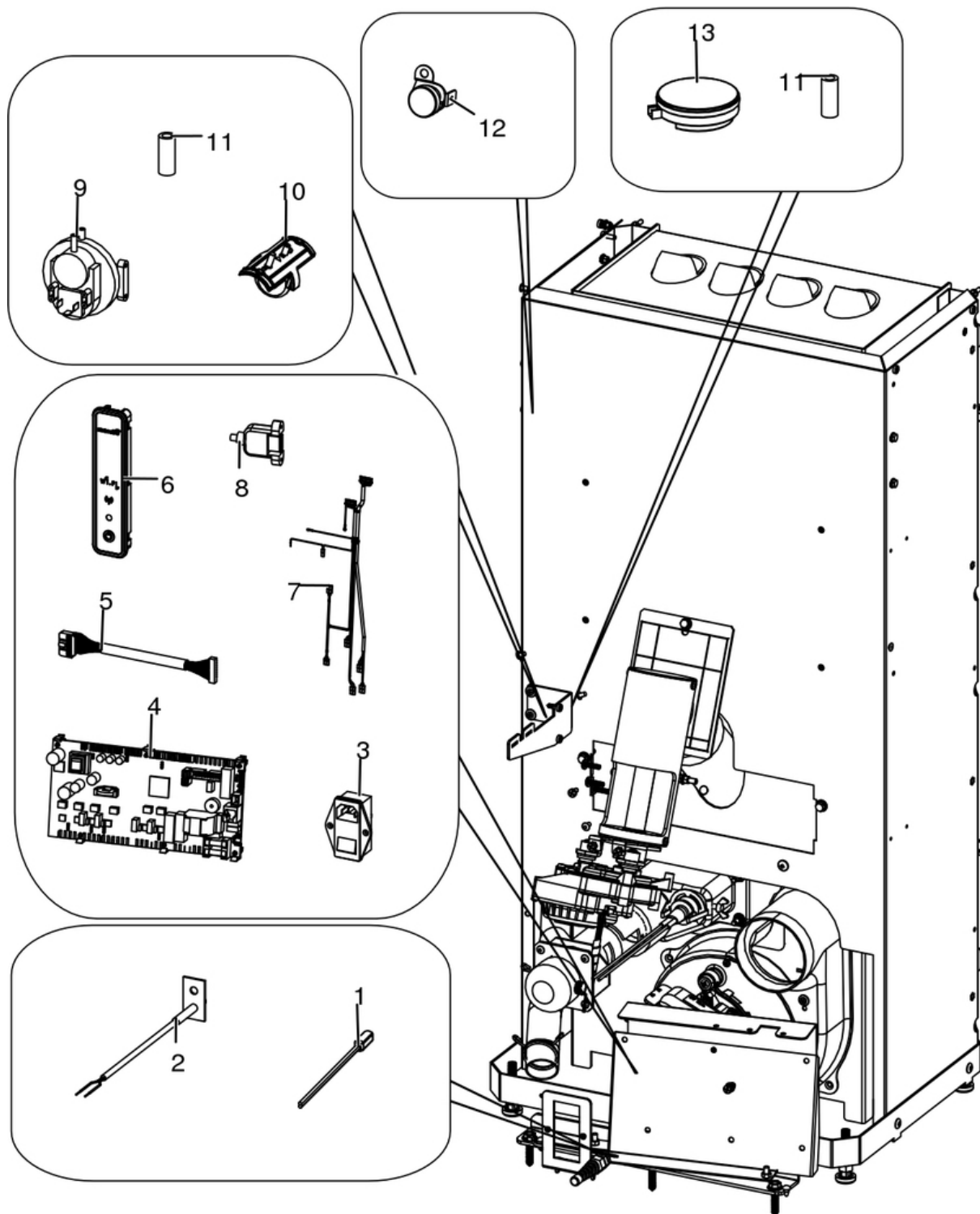

N°	Codice/Code	Descrizioni / Description / Beschreibung / Description / Descripción
1	4160386	Sonda temperatura ambiente/acqua / Room/Water temperature sensor / Raum- Wassertemperaturfühler / Sonde température ambiance/eau / Sonda temperatura ambiente/agua
2	41451703600	Sonda fumi con flangia con morsettiera L.980 / Smoke sensor with flange with terminal board L.980 / Rauchsonde mit Flansche mit Klemmenbrett L.980 / Sonde fumées avec bride avec serre-câble L.980 / Sonda humos con brida

		con borne L.980
3	4160193	Pulsante accensione / On/Off button / Zündungstaste / Touche d'allumage / Botón encendido
4	41451802200	Scheda elettronica / Electronic board / Elektronische Platine / Carte electronique / Tarjeta electronica
5	41451801600	Cavo flat 20 vie L.600 mm / Flat cable 20 pin L.600 mm / Flat-Kabel 20polig L.600 mm / Cable flat 20 voies L.600 mm / Flat cable 20 vias L.600 mm
6	41451602802	Pannello di emergenza Wireless / Wireless emergency display / Wireless Notfall-Blende / Panneau d'urgence wireless / Panel emergencia wireless
7	41451801400	Cablaggio / Wiring / Verdrahtung / Cablage / Cableado
7	41451803550	Kit cablaggi messa a terra / Grounding wiring kit / Erdungskabelbaum / Kit mise à terre / Kit cableado a tierra
7	41452000500	Cavo motoriduttore / Reduction motor cable / Kabel Getriebemotor / Câble motoréducteur / Cable motorreductor
8	41451403200	Cavo USB da pannello L.500 / USB Cable from display L.500 / USB Kabel von Notfalldisplay L.500 / Câble USB de panneau L.500 / Cable USB del panel L.500
9	41451003700	Pressostato / Pressure switch / Druckschalter / Pressostat / Presostato
10	41601301850	Componente rilevamento portata aria / Air flow measure component / Bauteil für Messung der Luftmenge / Composent pour la mesuration de la quantité d'air / Componente por la medida de l'aire
11	4120631A	Tubicino siliconico - 5m / Silicon tube - 5m / Silikonrohr - 5m / Petit tuyau en silicone - 5m / Tubo silicónico - 5m
12	412007004	Clickson 110°C / Clickson 110°C / Clickson 110°C / Clickson 110°C / Clickson 110°C
13	41451303400	Trasduttore di pressione / Pressure transducer / Active-Wandler / Transducteur de pression / Transductor de pression

AIKE COMFORT AIR 8 M1

Gruppo elettrico ed elettronico dal SN 2104070030010 / Electrical and electronic group starting from SN 2104070030010 / Elektrische und elektronische Gruppe ab SN 2104070030010 / Groupe électrique et électronique à partir du NS 2104070030010 / Grupo eléctrico y electrónico a partir de NS 2104070030010

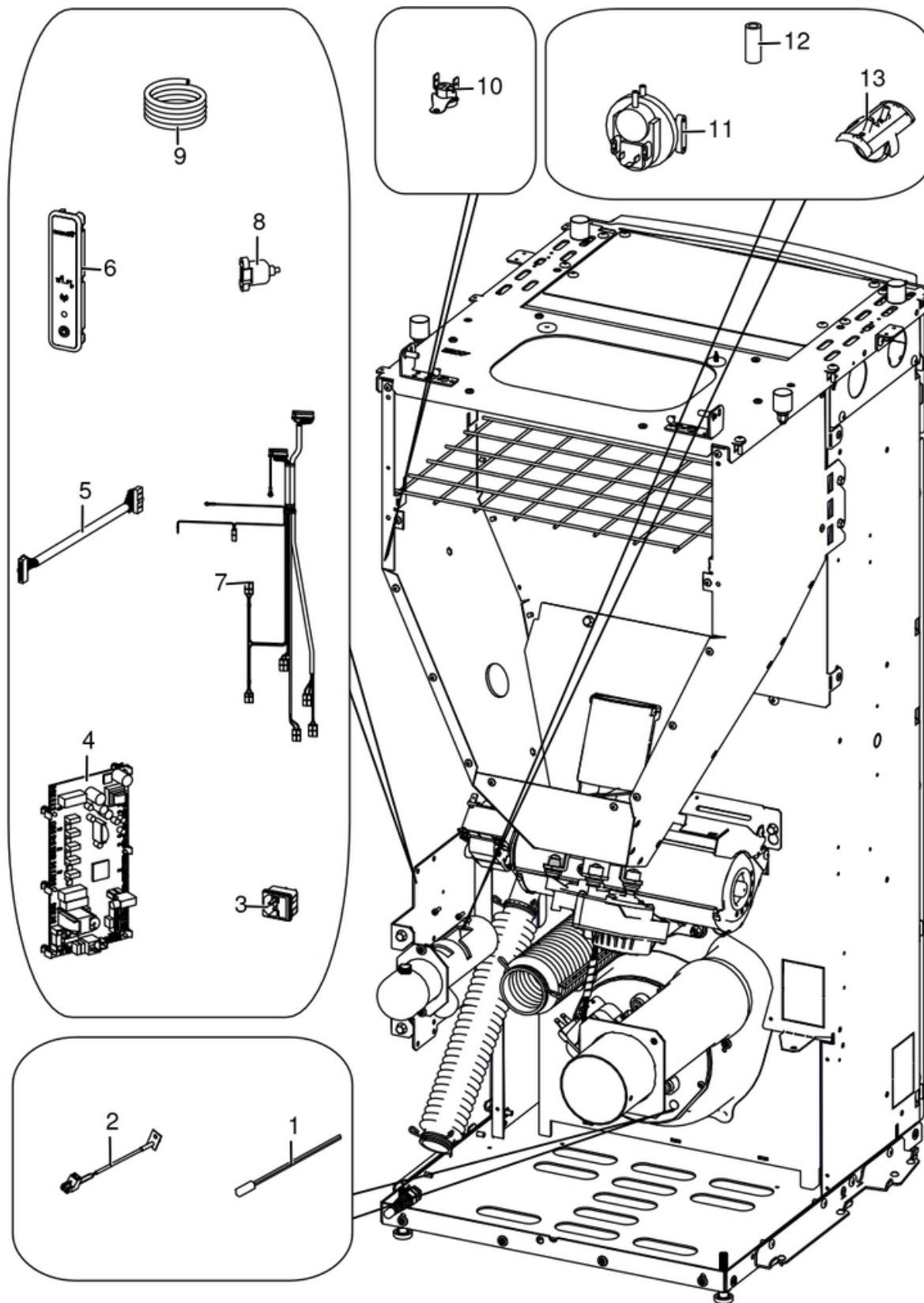

N°	Codice/Code	Descrizioni / Description / Beschreibung / Description / Descripcion
1	4160386	Sonda temperatura ambiente/acqua / Room/Water temperature sensor / Raum- Wassertemperaturfühler / Sonde température ambiance/eau / Sonda temperatura ambiente/agua
2	41451703600	Sonda fumi con flangia con morsettiera L.980 / Smoke sensor with flange with terminal board L.980 / Rauchsonde mit Flansche mit Klemmenbrett L.980 / Sonde fumées avec bride avec serre-câble L.980 / Sonda humos con brida con borne L.980
3	41451104100	Presca con fusibile / Socket with fuse / Steckdose mit Sicherung / Prise avec fusible / Toma con fusible
4	41451904300	Scheda madre / Motherboard / Hauptplatine / Carte mère / Tarjeta madre
4	41451904300A	Sensirion / Sensirion / Sensirion / Sensirion / Sensirion
5	41451801600	Cavo flat 20 vie L.600 mm / Flat cable 20 pin L.600 mm / Flat-Kabel 20polig L.600 mm / Cable flat 20 voies L.600 mm / Flat cable 20 vias L.600 mm
6	41451602801	Pannello di emergenza Wireless / Wireless emergency display / Wireless Notfall-Blende / Panneau d'urgence wireless / Panel emergencia wireless
7	41451800302	Cablaggio elettrico / Electrical wiring / Elektrische Verkabelung / Câblage électrique / Cableado eléctrico
7	41451803550	Kit cablaggi messa a terra / Grounding wiring kit / Erdungskabelbaum / Kit mise à terre / Kit cableado a tierra
8	41451403200	Cavo USB da pannello L.500 / USB Cable from display L.500 / USB Kabel von Notfalldisplay L.500 / Câble USB de panneau L.500 / Cable USB del panel L.500
9	41801902500	Spirale Rilsan (30 m.) / Rilsan spiral (30 m.) / Spirale Rilsan (30 M.) / Spirale Rilsan (30 m.) / Espiral Rilsan (30 m.)
9	41801902500A	Spirale Rilsan (5 spire) / Rilsan spiral (5 coils) / Spirale Rilsan (5 Windungen) / Spirale Rilsan (5 spires) / Espiral Rilsan (5 espire)
10	412007004	Clickson 110°C / Clickson 110°C / Clickson 110°C / Clickson 110°C / Clickson 110°C
11	41451003700	Pressostato / Pressure switch / Druckschalter / Pressostat / Presostato
12	4120631A	Tubicino siliconico - 5m / Silicon tube - 5m / Silikonrohr - 5m / Petit tuyau en silicone - 5m / Tubo silicónico - 5m
13	41601301850	Componente rilevamento portata aria / Air flow measure component / Bauteil für Messung der Luftmenge / Composent pour la mesuration de la quantité d'air / Componente por la medida de l'aire

AIKE COMFORT AIR 8 M1

Gruppo fumi / Smoke group / Rauchgruppe / Groupe fumées / Grupo de humos

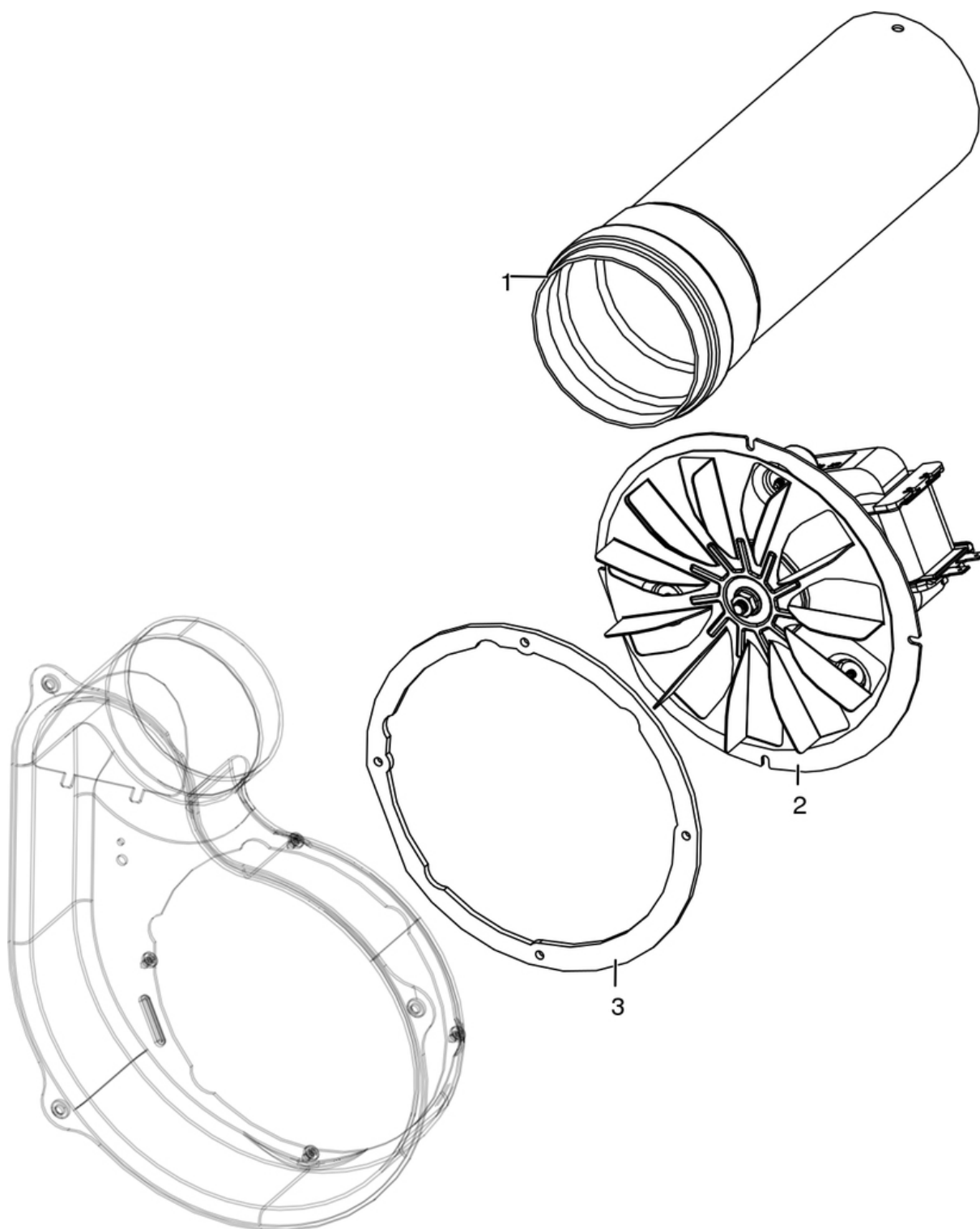

N°	Codice/Code	Descrizioni / Description / Beschreibung / Description / Descripcion
1	41601604560	Tubo fumi Ø 80 con guarnizione / Smoke pipe Ø 80 with gasket / Rauchrohr Ø 80 mit Dichtung / Tuyau fumées Ø 80 avec joint / Tubo humos Ø 80 con junta
2	41451503200	Ventilatore fumi stagno / Air-tight smoke exhausted fan / Luftdichtes Rauchgasgebläse / Ventilateur fumées étanche / Ventilador humos hermético
2	41451209300	Encoder per ventilatore fumi marchi LN2/SIT / Encoder for LN2/SIT smoke fan / Encoder für LN2/SIT

		Rauchgasgebläse / Encoder pour ventilateur des fumées marques LN2/SIT / Encoder para ventilador humos marcas LN2/SIT
2	41451703000	Encoder per ventilatore fumi marchio EBM / Encoder for EMB smoke fan / Encoder für EBM Rauchgasgebläse / Encoder pour ventilateur des fumées marque EBM / Encoder para ventilador humos marca EBM
2	41452009200	Encoder ventilatore / Fan encoder / Lüfter Encoder / Encodeur de ventilateur / Codificador de ventilador
3	41801600800	Guarnizione ventilatore fumi / Smoke exhaust fan gasket / Dichtung Rauchabsauggebläse / Joint Ventilateur aspiration fumées / Junta ventilador aspiración humos

AIKE COMFORT AIR 8 M1

Gruppo ventilazione / Ventilation group / Lüftungsgruppe / Groupe de ventilation / Grupo de ventilación

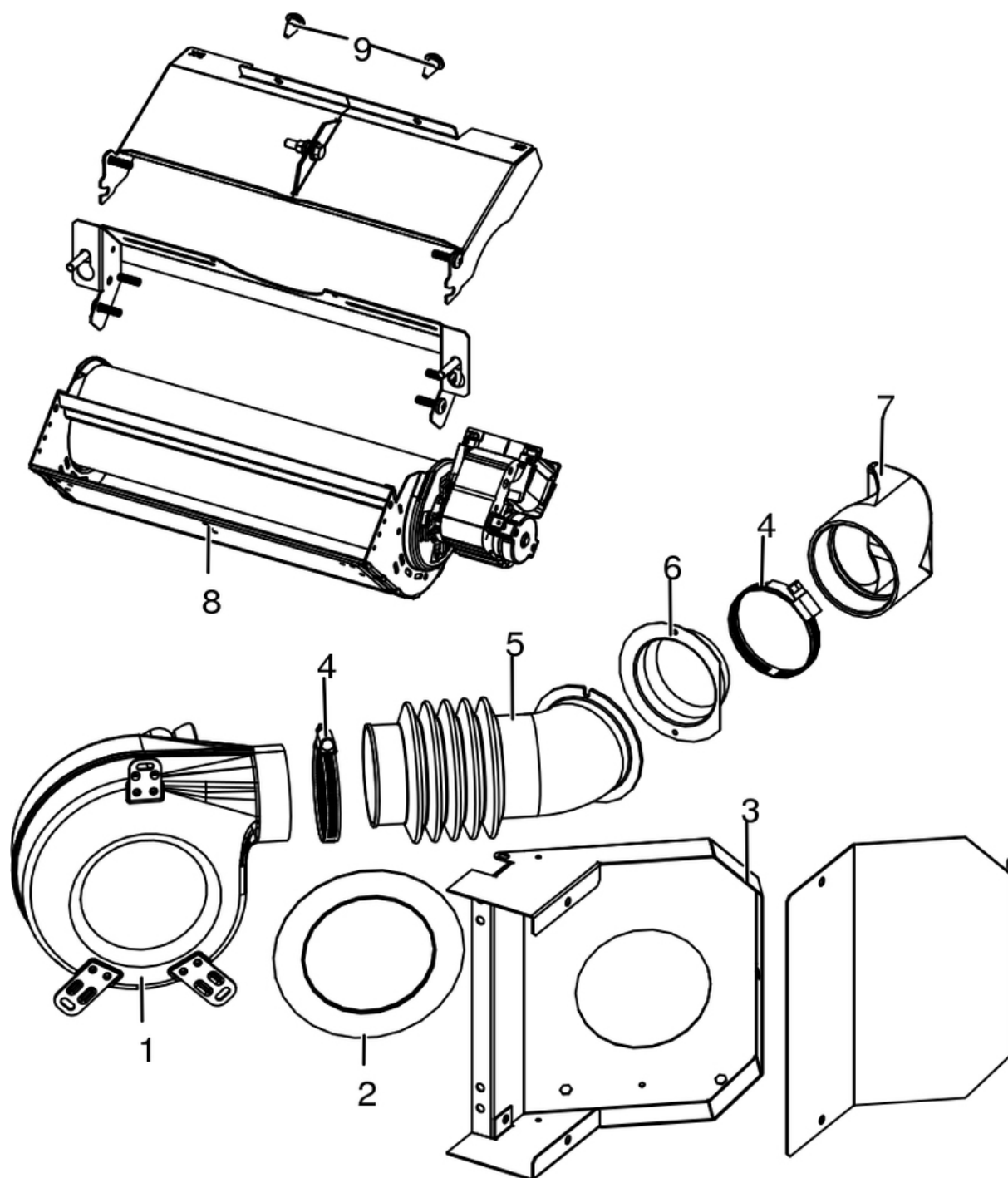

N°	Codice/Code	Descrizioni / Description / Beschreibung / Description / Descripción
1	41451503300	Ventilatore centrifugo / Air fan / Lufgebläse / Ventilateur air / Ventilador aire
2	41801601600	Guarnizione ventilatore / Fan gasket / Dichtung des Gebläses / Joint du ventilateur / Junta ventilador
3	41401624731	Convogliatore C/Air / Conveyor C/Air / Blech C/Air / Convoyeur C/Air / Conductor C/Air
4	41200902000	Fascette Ø 64-76 mm (2 pz) / Clamps Ø 64-76 mm (2 pcs) / Rohrschellen Ø 64-76 mm (2 Stck) / Colliers Ø 64-76 mm (2 pcs) / Bandas Ø 64-76 mm (2 pzs)
5	41801601100	Tubo uscita aria silicone / Outlet air tube in silicone / Luftausgangrohr aus Silikon / Tuyau de sortie air en silicone / Tubo de salida aire en silicona
6	4011011	Flangia Ø 6 / Flange Ø 6 / Flansch Ø 6 / Bride Ø 6 / Brida Ø 6

7	41801605300	Bocchetta posteriore in silicone / Silicone rear air outlet / Luftauslass aus Silikon / Diffuseur air en silicone / Boquilla aire en silicona
8	41451600800	Ventilatore aria / Air fan / Luftgebläse / Ventilateur air / Ventilador aire
9	41801002300	Paracolpi in silicone Ø 8/5 (2pz) / Silicone bumpers Ø 8/5 (2pcs) / Schlagschutzgummi Ø 8/5 (2 Stck) / Pièces silicone antichoc Ø 8/5 (2pcs) / Anti-golpes en silicona Ø 8/5 (2pzs)