

## STREAM COMFORT AIR 12/12 UP! M1 - 2020 VERSION

Gruppo estetico / Aesthetic group / Aesthetische Gruppe / Groupe esthétique / Grupo estético

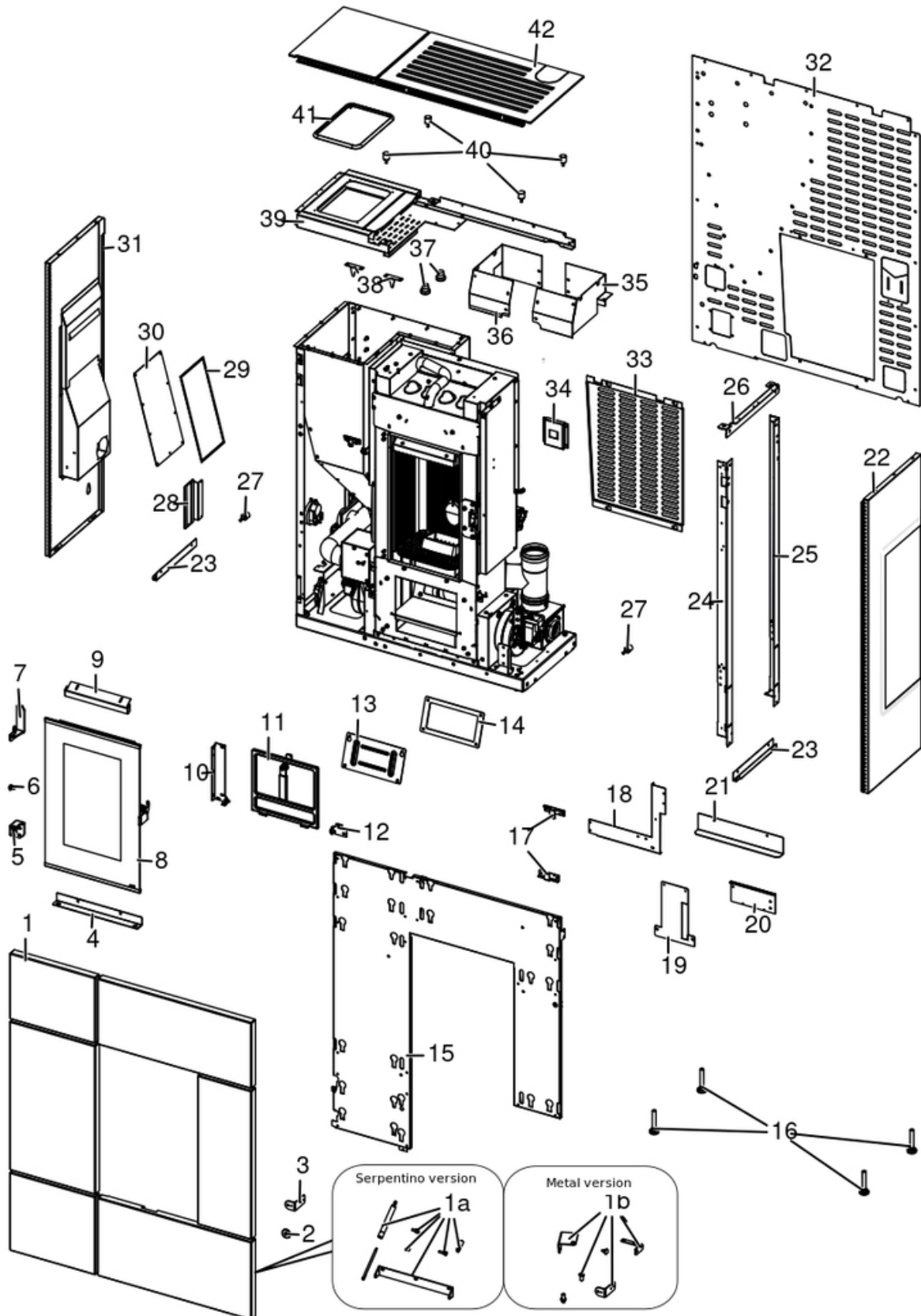

N°	Codice/Code	Descrizioni / Description / Beschreibung / Description / Descripcion
1	6920056	Rivestimento White Metal / White Metal cladding / Verkleidung White Metal / Habillage White Metal / White Metal Revestimiento
1	6920057	Rivestimento Bordeaux Metal / Bordeaux Metal cladding / Verkleidung Bordeaux Metal / Habillage Bordeaux Metal / Bordeaux Metal Revestimiento
1	6920058	Rivestimento Dark Metal / Dark Metal cladding / Verkleidung Dark Metal / Habillage Dark Metal / Dark Metal Revestimiento
1	6920059	Rivestimento Serpentino / Serpentino Metal cladding / Verkleidung Serpentino Metal / Habillage Serpentino Metal / Serpentino Metal Revestimiento
1a	41411999850	Kit ferramenta / Hardware kit / Eisenwaren Kit / Kit de quincailleries / Kit de hardware
1b	41411999950	Kit ferramenta / Hardware kit / Eisenwaren Kit / Kit de quincailleries / Kit de hardware
1b	41801002300	Paracolpi in silicone Ø 8/5 (2pz) / Silicone bumpers Ø 8/5 (2pcs) / Schlagschutzgummi Ø 8/5 (2 Stck) / Pièces silicone antichoc Ø 8/5 (2pcs) / Anti-golpes en silicona Ø 8/5 (2pzs)
2	41801657900	Magneti (pz.2) / Magnet (pcs.2) / Magnet (stk. 2) / Aimant (pcs.2) / Imán (pz.2)
3	41401850730	Staffa magnete / Magnet support / Magnetstütze / Support aimant / Soporte iman
4	4140184843000	Staffa copri cenere / Ash cover bracket / Aschenabdeckung- Bügel / Supprt couverture cendre / Estribo tapa ceniza
5	4140184694000	Cerniera inferiore completa nera / Black lower complete hinge / Komplettes schwarze untere Scharnier / Charnière inférieure noire complète / Bisagra inferior negra completa
6	41801002300	Paracolpi in silicone Ø 8/5 (2pz) / Silicone bumpers Ø 8/5 (2pcs) / Schlagschutzgummi Ø 8/5 (2 Stck) / Pièces silicone antichoc Ø 8/5 (2pcs) / Anti-golpes en silicona Ø 8/5 (2pzs)
7	4140184684000	Cerniera superiore completa nera / Black upper complete hinge / Komplettes schwarze obere Scharnier / Charnière supérieure noire complète / Bisagra superior negra completa
8	437018298	Porta / Door / Tür / Porte / Puerta
9	41411615430V	Deflettore aria / Air deflector / Luftleitblech / Déflecteur aire / Deflector aire
10	4140184704000	Cerniera completa tappo inferiore sx / Lower LH cover complete hinge / Komplettes Scharnier der untere linke Abdeckung / Charnière complète du couvercle inférieur gauche / Bisagra completa tapon inferior izquierdo
11	437016130	Porta cenere con maniglia / Ash drawer door with handle / Tür des Aschenkastens mit Griff / Porte tiroir à cendres avec poignée / Puerta cajón ceniza con tirador
12	41411674540V	Supporto sportello cenere / Ash drawer support / Aschenkasten Stütze / Support tiroir à cendres / Soporte Cajón ceniza
13	41401339610	Tappo ispezione vano fumi / Smoke compartment inspection plug / Inspektionsdeckel Rauchabzug / Clapet inspection compartiment fumées / Tapón inspección compartimento humos
14	41800900600	Guarnizione / Gasket / Dichtung / Joint / Junta
14	41801599750	Kit 50 guarnizioni / Kit 50 gaskets / Bausatz 50 Dichtungen / Kit 50 joints / Kit 50 juntas
15	4140204353000	Piastra base estetiche / Aesthetic base plate / ästhetische Grundplatte / Plaque de base esthétique / Placa base estética
16	41200906660	Piedini di appoggio (4 pz.) / Support feet (4 pcs.) / Einstellfüße (4 Stck.) / Vérins d'appui (4 p.es) / Pies de apoyo (4 piezas)
17	41402043230	Staffa fissaggio / Fixing bracket / Befestigungswinkel / Support de fixation / Soporte de fijación
18	41402043430	Staffa intermedia Sx / Middle LH bracket / Mitte linke Halterung / Mi- gauche support / Soporte intermedio IZDO
19	41401848611	Schermo antiintrusione / Protection plate / Schutzplatte / Panel de protection / Pantalla de protección
20	41402043130	Flangia fissaggio / Fixing flange / Befestigungsflansch / Bride de fixation / Brida de fijación
21	4140204593000	Schermo calore / Heat plate / Hitzeschild / Panel chaleur / Pantalla calor
22	4140184564000	Fianco destro completo Dark / Complete RH side Dark / Komplette Rechte Seite Dark / Côté droite complet Dark / Lateral completo DCHO Dark
23	41401849830	Staffa supporto fianchi dx/sx / LH/RH side support bracket / Seitenhaltebügel Rechts/Liks / Étrier support cotés droite/gauche / Estribo soporte lado derecho/izquierdo
24	41401848130	Montante anteriore dx / RH front upright / Vordere Säule rechts / Droit frontal doite / Vertical delantero derecho
25	41401848230	Montante posteriore dx / RH back upright / Hintere Säule links / Droit postérieur droite / Vertical posterior izquierdo
26	41401848730	Traversa laterale / Lateral crossbeam / seitlicher Träger / Traverse latérale / Traversa lateral
27	41201501900	Antivibranti (10 pz) / Anti-vibration mountings (10 pcs) / Schwingungsdämpfend (10 Stck.) / Eléments antivibrations (10 pcs) / Anti-vibraciones (10 pzs)
28	41401847730	Supporto / Bracket / Gestell / Support / Soporte
29	4120572A	Guarnizione a nastro 6 mm (5 mt.) per porta / Door strip gasket 6 mm (5 m) / Türbanddichtung 6 mm ( 5 m) / Joint ruban 6 mm (5 m) pour porte / Guarnición de cinta para puerta 6 mm (5 m)
29	4120572B	Guarnizione a nastro 6 mm (50 mt.) per porta / Door strip gasket 6 mm (50 m) / Türbanddichtung 6 mm (50 m) / Joint ruban 6 mm (50 m) pour porte / Guarnición de cinta para puerta 6 mm (50 m)

<b>30</b>	<b>41401824511</b>	Tappo serbatoio / Hopper cover / Deckel Behälter / Couvercle réservoir / Tapa depósito
<b>31</b>	<b>4140184574000</b>	Fianco sinistro completo Dark / Complete LH side Dark / Komplette Linke Seite Dark / Côté gauche complet Dark / Lateral completo izquierdo Dark
<b>32</b>	<b>41401847510</b>	Schiena / Back / Rückwand / Dosseret / Panel trasero
<b>33</b>	<b>41401825631</b>	Coperchio schiena / Back cover / Rückwand Deckel / Couvercle du dosseret / Tapadera panel trasero
<b>34</b>	<b>41401601830</b>	Supporto interruttore / Switch support / Unterstützung On/Off Taste / Support interrupteur / Apoyo Interruptor
<b>35</b>	<b>4140184923000</b>	Schermo frontale dx nero / RH frontal black plate / Schwarze rechte Platte vorne / Panel frontal droite noir / Pantalla negra frontal derecha
<b>36</b>	<b>4140184913000</b>	Schermo frontale sx nero / LH frontal black plate / Schwarze linke Platte vorne / Panel frontal gauche noir / Pantalla negra frontal izquierda
<b>37</b>	<b>4120180</b>	Gommini paracolpi (4 pz) / Rubber bumpers (4 pcs.) / Schlagschutzgummi (4 Stck) / Pièces caoutchouc antichoc (4 pcs) / Cauchitos anti-golpes (4 pz)
<b>38</b>	<b>4140204653000</b>	Staffa chiusura / Closing bracket / Bügel für Schließung / Équerre de fermeture / Soporte de cierre
<b>39</b>	<b>41401845450</b>	Supporto top / Top support / Deckelhalbtebügel / Support du dessus / Soporte del top
<b>40</b>	<b>41201105600</b>	Antivibranti (10 pz) / anti-vibration mountings (10 pcs) / Schwingungsdämpfer (10 Stck) / Éléments antivibratoires (10 pcs) / Anti-vibraciones (10 pz)
<b>41</b>	<b>41801504700</b>	Guarnizione tenuta serbatoio / Pellet hopper gasket / Pelletbehälter Dichtung / Joint réservoir pellet / Junta depósito pellet
<b>42</b>	<b>41421813650</b>	Top completo / Complete Top / Komplette Top / Top complet / Top completo

## STREAM COMFORT AIR 12/12 UP! M1 - 2020 VERSION

Gruppo camera di combustione / Combustion chamber group / Verbrennungskammer Gruppe / Group de chambre de combustion / Grupo cámara de combustión

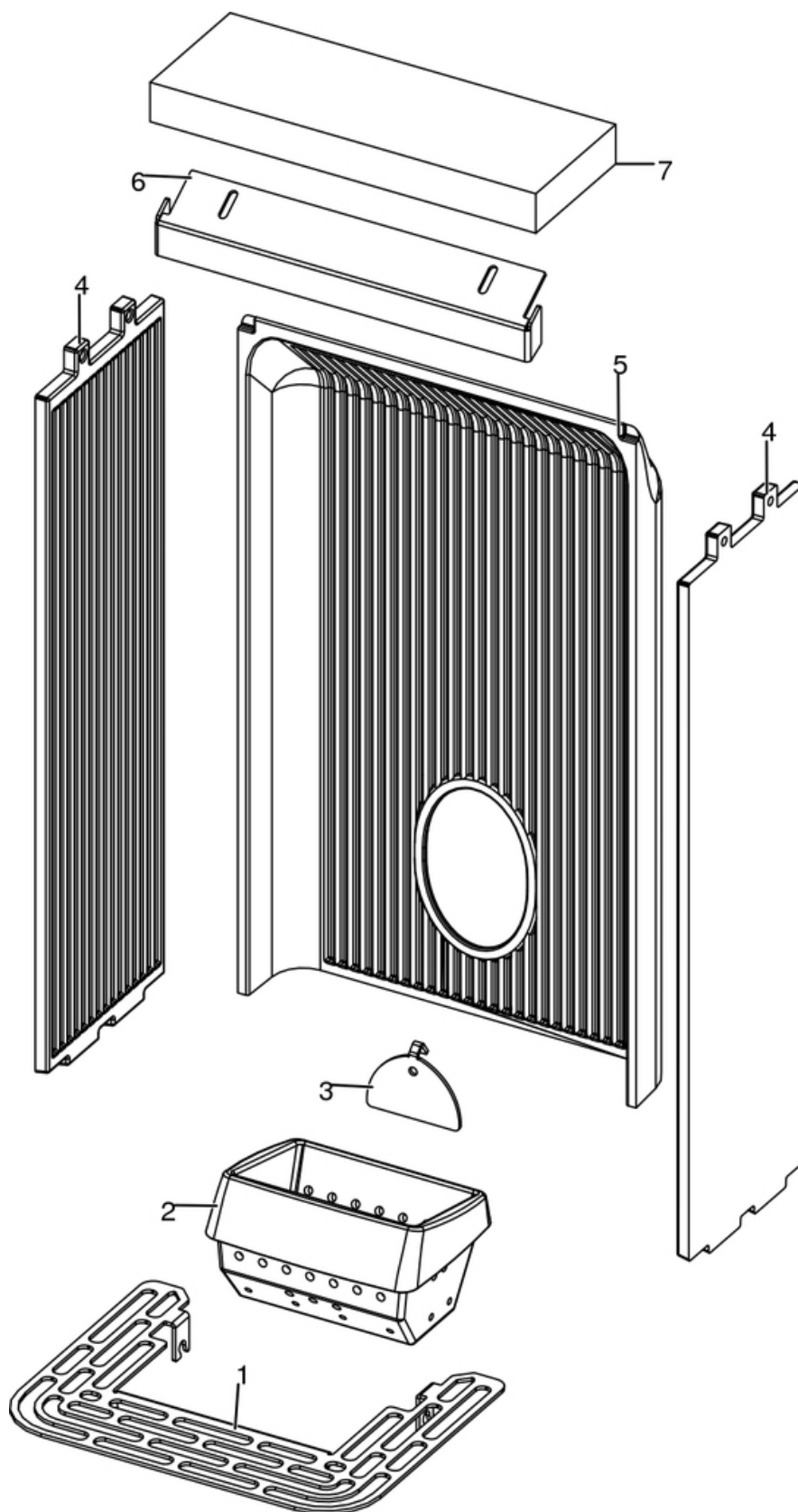

N°	Codice/Code	Descrizioni / Description / Beschreibung / Description / Descripcion
1	41411634830V	Griglia focolare / Fire Box Grille / Feuerstellenrost / Grille Foyer / Rejilla Hogar
2	41301502400V	Braciare ghisa / Cast iron grate / Brennertopf aus Gusseisen / Brasero en fonte / Brasero en arrabio
3	41411613530V	Deflettore pellet / Pellet deflector / Pellet Leitblech / Deflecteur pellet / Deflector pellet
4	41301502500V	Fianco ghisa / Cast iron side / Seite aus Guß / Côté en fonte / Placa lateral de arrabio
5	41301502600V	Schiena ghisa / Cast iron back / Rückwand aus Gusseisen / Dossieret en fonte / Parte trasera en arrabio
6	41411615430V	Deflettore aria / Air deflector / Luftleitblech / Déflecteur aire / Deflector aire
7	41151600200	Deflettore focolare in vermiculite / Vermiculite deflector / Leitblech aus Vermiculite / Déflecteur en vermiculite / Deflector en vermiculite

## STREAM COMFORT AIR 12/12 UP! M1 - 2020 VERSION

Porta fuoco / Fire door / Feuertür / Porte foyer / Puerta hogar

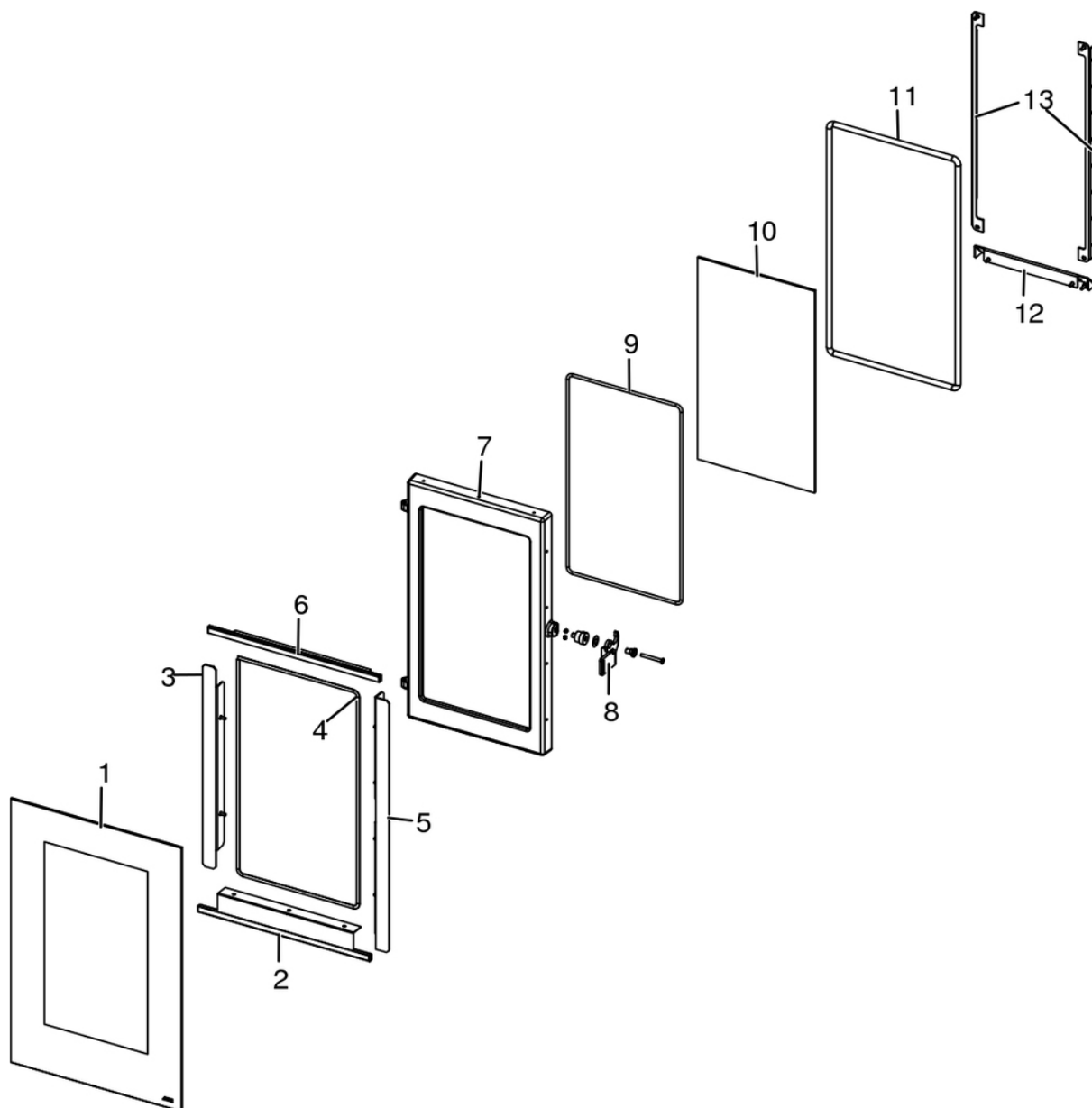

N°	Codice/Code	Descrizioni / Description / Beschreibung / Description / Description
1	41701802860	Vetro porta fuoco / Fire door glass / Feuertürscheibe / Vitre porte feu / Cristal puerta fuego
2	4140184323000	Fermavetro inferiore / Lower guard glas / Unteres Haltebügel für Scheibebefestigung / Patte de fixation vitrocéramique inférieure / Fermacristal inferior
3	4140185013000	Fermo porta nero / Black doorstop / Schwarze Türbefestigung / Fermature de porte noire / Cerre de la porta negro
4	4120572A	Guarnizione a nastro 6 mm (5 mt.) per porta / Door strip gasket 6 mm (5 m) / Türbanddichtung 6 mm ( 5 m) / Joint ruban 6 mm (5 m) pour porte / Guarnición de cinta para puerta 6 mm (5 m)
4	4120572B	Guarnizione a nastro 6 mm (50 mt.) per porta / Door strip gasket 6 mm (50 m) / Türbanddichtung 6 mm (50 m) / Joint ruban 6 mm (50 m) pour porte / Guarnición de cinta para puerta 6 mm (50 m)
5	4140184333000	Cornice laterale nera / Lateral black Frame / Schwarz seitliche Rahmen / Encadrement latéral noir / Marco lateral negro
6	4140184313000	Fermavetro superiore / Upper guard glas / Oberes Haltebügel für Scheibebefestigung / Patte de fixation vitrocéramique supérieure / Fermacristal superior
7	4130180140100	Porta in ghisa nera / Cast iron black door / Feuertür aus schwarzen Gusseisen / Porte foyer en fonte noir / Puerta de arrabio negro

<b>8</b>	<b>41401843460</b>	Maniglia / Handle / Griff / Türgriff / Tirador
<b>9</b>	<b>4120106</b>	Guarnizione a nastro fireglass / Fireglass tape gasket / Banddichtung Fireglass / Joint ruban Fireglass / Guarnición a cinta Fireglass
<b>10</b>	<b>41701600300</b>	Vetroceramico porta ghisa / Cast iron door glass / Glaskeramikscheibe Tür aus Gusseise / Vitrocéramique porte en fonte / Cristal cerámico puerta en arrabio
<b>11</b>	<b>4120103A</b>	Cordino fibrocaramico Ø 10 mm (5 mt.) / Ceramic fibre cord Ø 10 mm (5 m) / Keramikfaserschnur Ø 10 mm (5 m) / Cordon en fibre céramique Ø 10 mm (5 m) / Junta a cuerda de fibra cerámica Ø 10 mm (5 m)
<b>11</b>	<b>4120103B</b>	Cordino fibrocaramico Ø 10 mm (50 mt.) / Ceramic fibre cord Ø 10 mm (50 m) / Keramikfaserschnur Ø 10 mm (50 m) / Cordon en fibre céramique Ø 10 mm (50 m) / Junta a cuerda de fibra cerámica Ø 10 mm (50 m)
<b>11</b>	<b>41201031</b>	Kit sostituzione cordino (cordino+silicone) Ø 10 mm / Cord replacement kit (cord + silicon) Ø 10 mm / Schnuraustauschsatz (Schnur+Silikon) Ø 10 mm / Kit remplacement cordon (cordon + silicone) Ø 10 mm / Kit sustitución junta a cuerda (junta a cuerda+silicón) Ø 10 mm
<b>12</b>	<b>41411622130V</b>	Scivolo cenere / Ash ramp / Aschenrutsche / Glissèrie cendre / Tobogán ceniza
<b>13</b>	<b>41411622030V</b>	Profilo fermavetro / Fastening bracket profile / Haltebügel für Scheibebefestigung Profil / Profil patte de fixation / Perfil fermacrystal

## STREAM COMFORT AIR 12/12 UP! M1 - 2020 VERSION

Gruppo accensione / Ignition group / Entzündung Gruppe / Groupe d'allumage / Grupo ignición

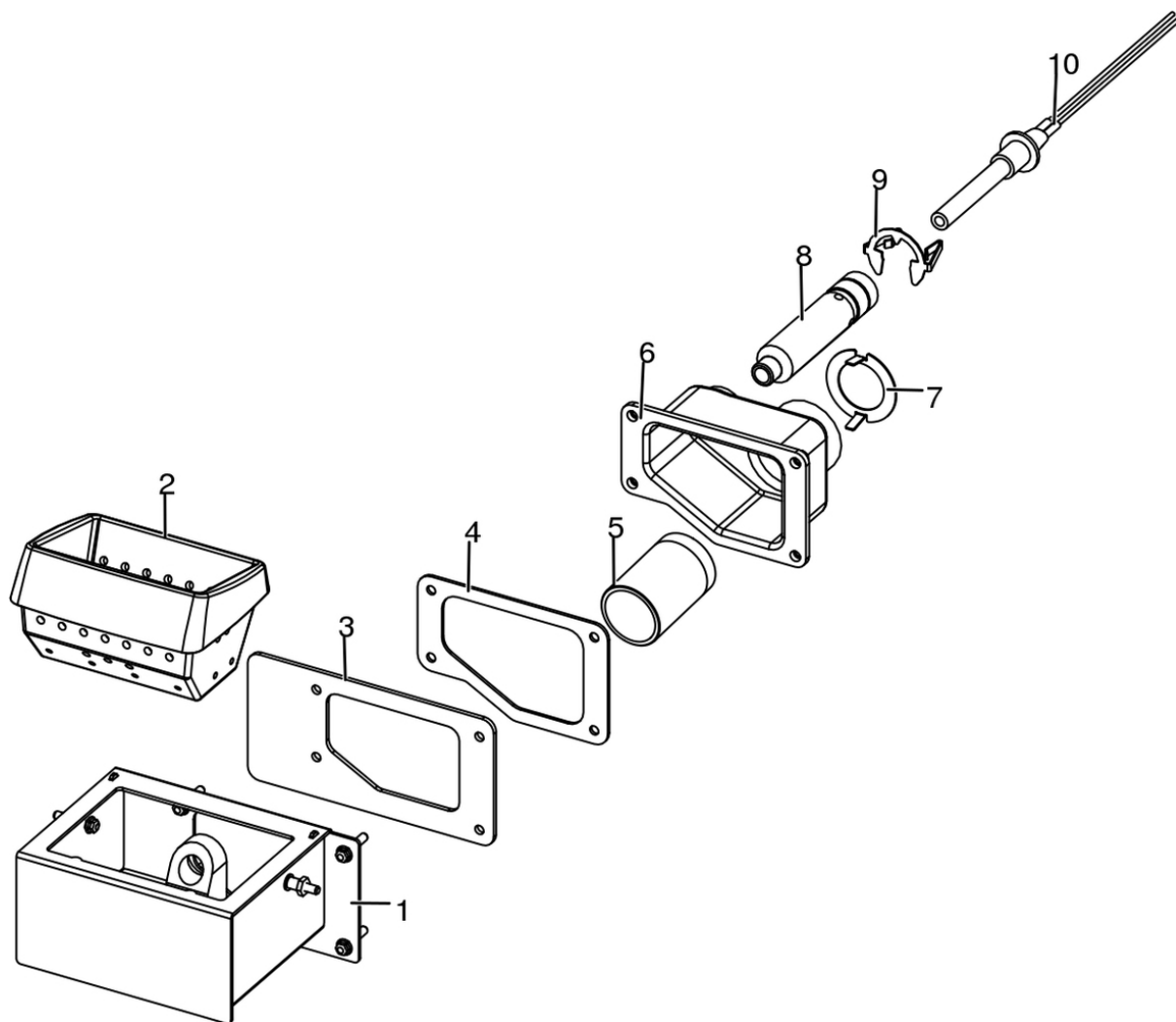

N°	Codice/Code	Descrizioni / Description / Beschreibung / Description / Descripción
1	41411613140V	Tasca braciere / Combustion pot container / Brenntopfkasten / Récipient brasero / Contenedor brasero
2	41301502400V	Braciere ghisa / Cast iron grate / Brennertopf aus Gusseisen / Brasero en fonte / Brasero en arrabio
3	41801601500	Guarnizione tasca braciere / Combustion pot container gasket / Brenntopfkasten Dichtung / Joint récipient brasero / Junta contenedor brasero
4	41801602300	Guarnizione codolo / Gasket / Dichtung / Joint / Junta
5	41501701599	Manicotto potenziamento accensione / Combustion air extension pipe / Zusatzrohr für Nachrüstung / Tuyau amélioration allumage / Tubo impulso de encendido
6	41311803500	Codolo / Tool chuck / Einspannschaft / Outil d'emmanchement / Mango
7	41401629410	Regolatore ingresso aria comburente / Combustion air intake adjuster / Regler Eingang Verbrennungsluft / Régulateur arrivée air comburant / Regulador entrada aire comburente
8	41601601000	Condotto candelella / Sparkplug Conduit / Zündkerzenkanal / Conduit Bougie / Conducto Bujía
9	41201601500	Anello arresto candelella / Sparkplug stop / Zündkerzestopper / Butée bougie / Tope bujía
10	41451308101	Candelella 315 Watt / Sparkplug 315 Watt / Zündkerze 315 Watt / Bougie 315 Watt / Bujía 315 Watt
10	41451308150	Kit 25 candelelle 315 Watt / 25 Sparkplugs 315 Watt kit / Bausatz 25 Zündkerzen 315 Watt / Kit 25 Bougies 315 Watt / Kit 25 Bujías 315 Watt



## STREAM COMFORT AIR 12/12 UP! M1 - 2020 VERSION

Gruppo caricamento pellet / Pellet feed group / Pellet Fördergruppe / Groupe chargement du pellet / Grupo de carga pellet

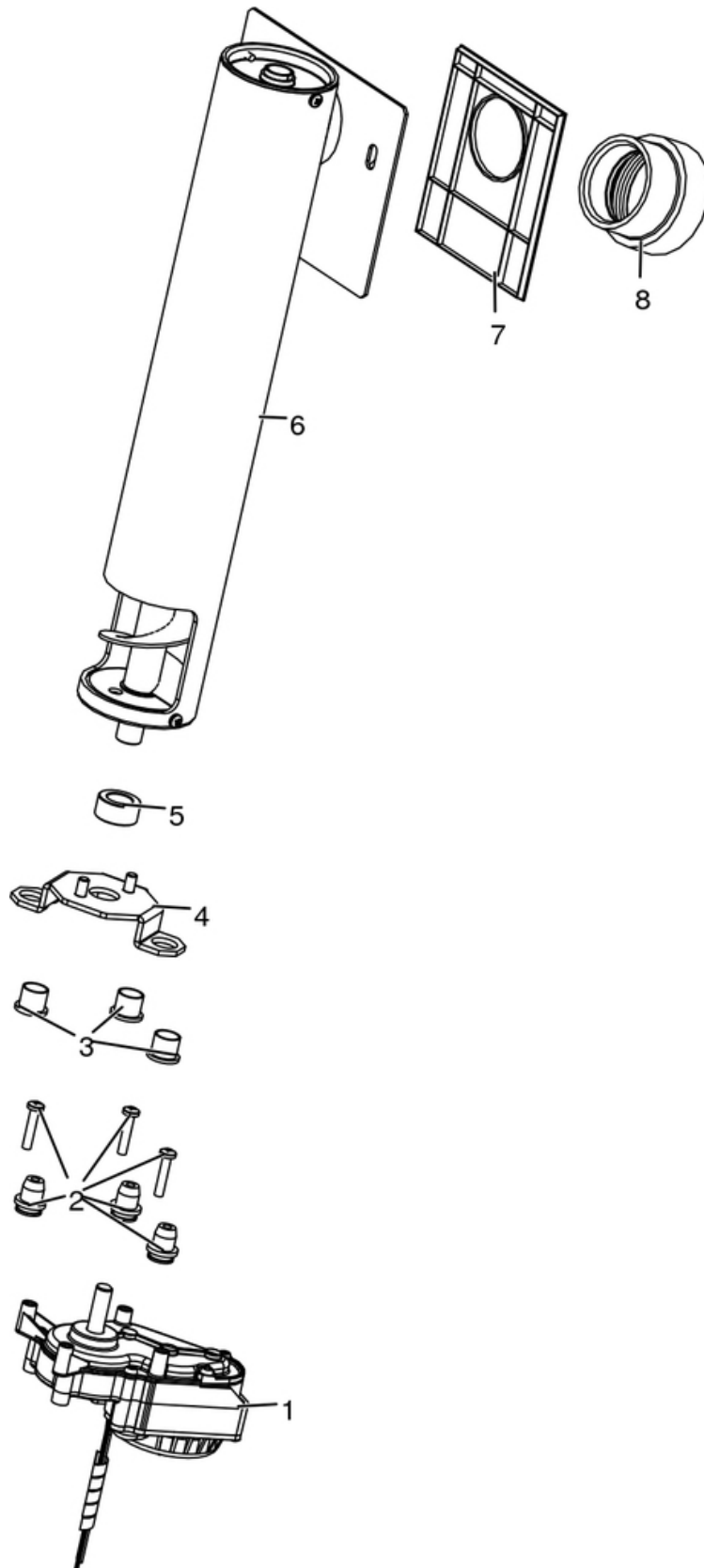

N°	Codice/Code	Descrizioni / Description / Beschreibung / Description / Descripción
1	41451702200	Motoriduttore brushless / Brushless reduction motor / Brushless Getriebemotor / Motoréducteur brushless / Motorreductor brushless
2	41801703700	Gommini antivibrante / Vibration damper rubber / Rammschutz Gummi / Caoutchouc antivibratoire / Cauchitos antivibración
3	41201800700	Boccola (3 pz) / Bushing (3 pcs) / Buchse (3 Stk) / Douille (3 pcs) / Abrazadera (3 pzs)
4	41411779331	Supporto coclea "Ragno" / Pellet feed screw bracket "spider" / "Spinne" Schenke Gestell / Support vis sans fin "Araignée" / Soporte coclea "Araña"
5	4120398	Connettore motoriduttore-coclea / Reduction motor-feed screw connector / Verbindung Getriebemotor-Schnecke / Connecteur motoréducteur-vis sans fin / Conector motorreductor-cóclea
6	41411881150	Assieme coclea / Auger set / Schneckebausatz / Groupe vis sans fin / Grupo vis sin fin
7	41801600400	Guarnizione gruppo caricamento / Gasket / Dichtung / Joint / Junta
8	41801702600	Disaccoppiatore mesc. Marrone / Brown disengaging device / Braun Verängungsrohr / Tuyau de découplage maron / Tubo de desvío marron

## STREAM COMFORT AIR 12/12 UP! M1 - 2020 VERSION

Porta cenere / Ash door / Ashentür / Porte cendre / Puerta ceniza

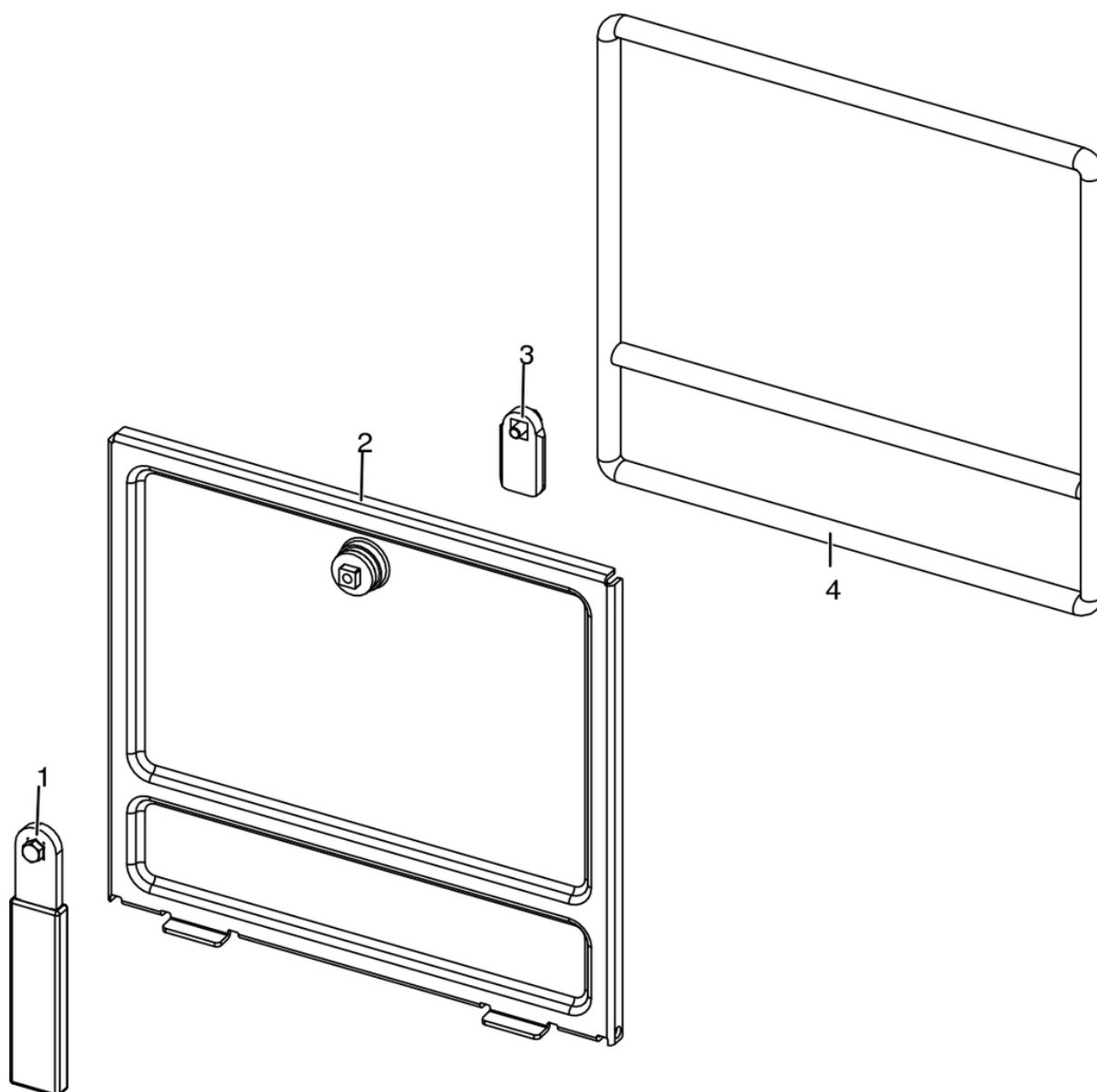

N°	Codice/Code	Descrizioni / Description / Beschreibung / Description / Descripción
1	41411621600	Maniglia con impugnatura porta cenere / Handle / Griff / Poignée / Tirador
2	41421602141V	Porta cenere / Ash drawer door / Tür des Aschenkastens / Porte tiroir à cendres / Puerta cajón ceniza
3	41201608400	Serratura porta cassetto cenere / Door lock for ash drawer / Türschloss für Aschenkasten / Serrure de porte du tiroir à cendres / Cerradura puerta cajón ceniza
4	412007003A	Cordino fibroceramico Ø 14 mm (5 mt.) / Ceramic fibre cord Ø 14 mm (5 m.) / Keramikfaserschnur Ø 14 mm (5 m) / Cordon en fibre céramique Ø 14 mm (5 m) / Junta a cuerda de fibra cerámica Ø 14 mm (5 m)
4	412007003B	Cordino fibroceramico Ø 14 mm (50 mt.) / Ceramic fibre cord Ø 14 mm (50 m.) / Keramikfaserschnur Ø 14 mm (50 m) / Cordon en fibre céramique Ø 14 mm (50 m) / Junta a cuerda de fibra cerámica Ø 14 mm (50 m)
4	412007003C	Kit sostituzione cordino (cordino+silicone) Ø 14 mm / Cord replacement kit (cord + silicon) Ø14 mm / Schnuraustauschsatz (Schnur +Silikon) Ø 14 mm / Kit remplacement cordon (cordon+silicon) Ø 14 / Kit sustitución junta a cuerda (junta a cuerda+silicón) Ø 14 mm

## STREAM COMFORT AIR 12/12 UP! M1 - 2020 VERSION

Gruppo aria comburente / Combustion air group / Verbrennungsluft Gruppe / Groupe air comburant / Grupo aire comburente

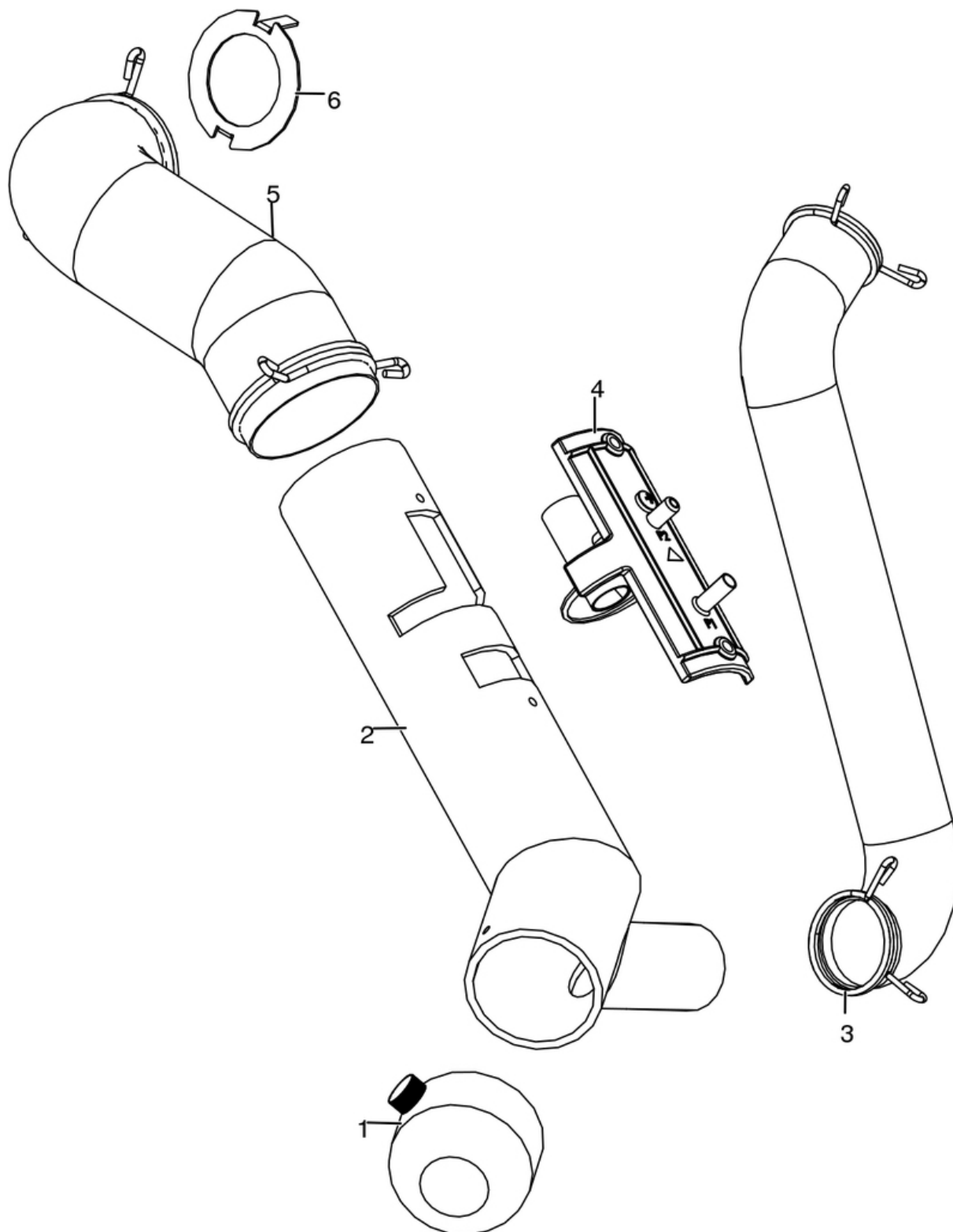

N°	Codice/Code	Descrizioni / Description / Beschreibung / Description / Description
1	41401036100	Filtro antipolvere / Anti-dust filter / Staubschutzfilter / Filtre antipoussière / Filtro de protección polvo
2	41601805760	Tubo aspirazione / Aspiration tube / Förderrohr / Tuyau aspiration / Tubo aspiración

<b>3</b>	<b>41801601900</b>	Tubo aspirazione pulizia vetro / Inlet pipe for cleaning glass air / Glassreinigungs Lufteingangrohr / Tuyau entrée pour l'aire de nettoyage du vitre / Tubo entrada por l'aire de limpieza vidrio
<b>4</b>	<b>41601301850</b>	Componente rilevamento portata aria / Air flow measure component / Bauteil für Messung der Luftmenge / Composent pour la mesuration de la quantité d'air / Componente por la medida de l'aire
<b>5</b>	<b>41801601700</b>	Tubo aspirazione camera combustione / Combustion chamber aspiration tube / Verbrennungskammer Förderrohr / Tuyay aspiration air chambre de combustion / Tubo aspiración aire cámara de combustión
<b>6</b>	<b>41401629410</b>	Regolatore ingresso aria comburente / Combustion air intake adjuster / Regler Eingang Verbrennungsluft / Régulateur arrivée air comburant / Regulador entrada aire comburente

## STREAM COMFORT AIR 12/12 UP! M1 - 2020 VERSION

Gruppo elettrico ed elettronico / Electrical and electronic group / Elektrische und elektronische Gruppe / Groupe électrique et électronique / Grupo eléctrico y electrónico

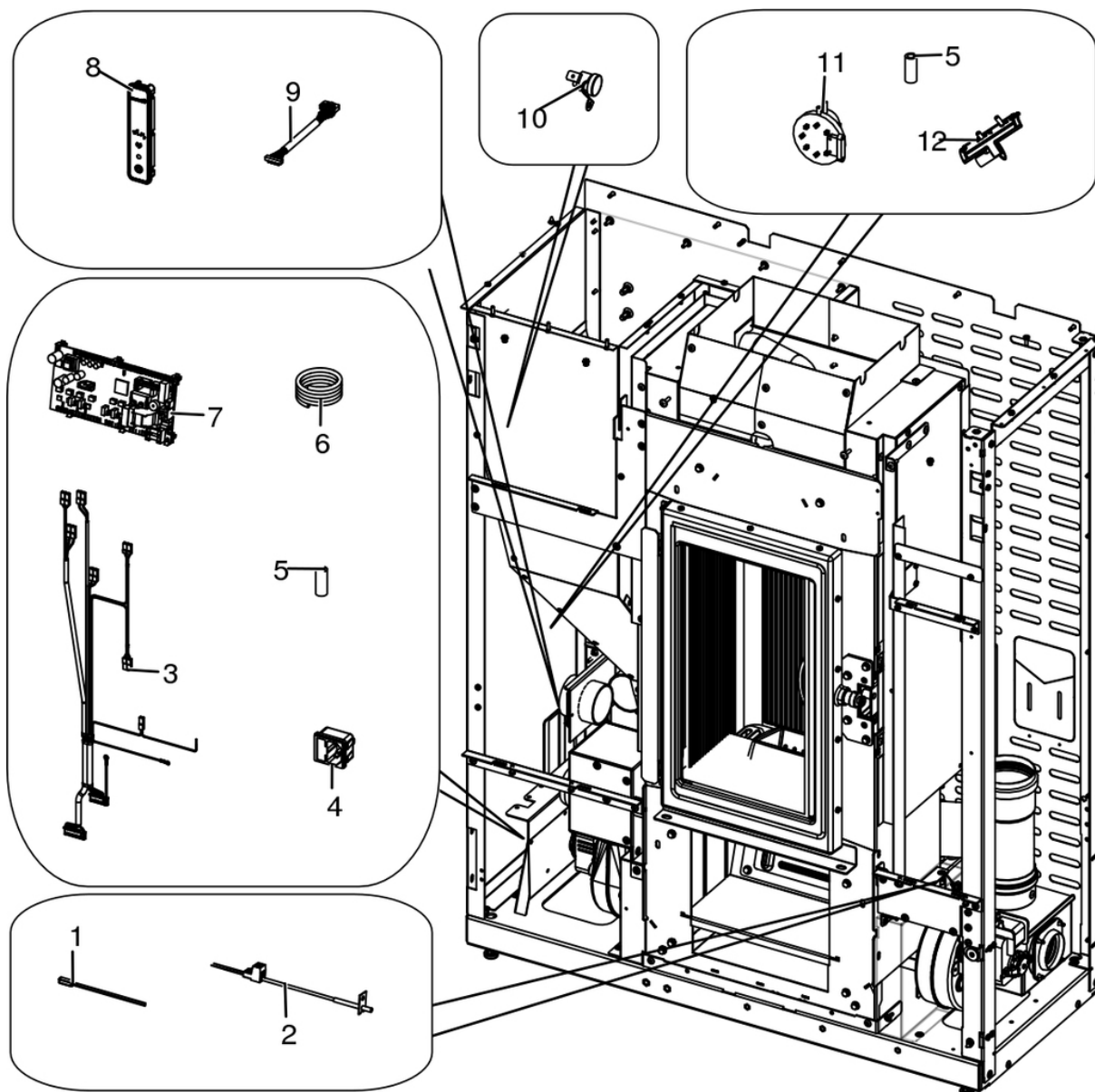

N°	Codice/Code	Descrizioni / Description / Beschreibung / Description / Descripción
1	4160386	Sonda temperatura ambiente/acqua / Room/Water temperature sensor / Raum- Wassertemperaturfühler / Sonde température ambiance/eau / Sonda temperatura ambiente/agua
2	41451703600	Sonda fumi con flangia con morsetti L.980 / Smoke sensor with flange with terminal board L.980 / Rauchsonde mit Flansche mit Klemmenbrett L.980 / Sonde fumées avec bride avec serre-câble L.980 / Sonda humos con brida con borne L.980
3	41451900900	Cablaggio elettrico / Electrical wiring / Elektrische Verkabelung / Câblage électrique / Cableado eléctrico
3	41451803550	Kit cablaggi messa a terra / Grounding wiring kit / Erdungskabelbaum / Kit mise à terre / Kit cableado a tierra
3	41452000500	Cavo motoriduttore / Reduction motor cable / Kabel Getriebemotor / Câble motoréducteur / Cable motorreductor
4	4160193	Pulsante accensione / On/Off button / Zündungstaste / Touche d'allumage / Botón encendido
5	4120631A	Tubicino siliconico - 5m / Silicon tube - 5m / Silikonrohr - 5m / Petit tuyau en silicone - 5m / Tubo silicónico - 5m
6	41801902500	Spirale Rilsan (30 m.) / Rilsan spiral (30 m.) / Spirale Rilsan (30 M.) / Spirale Rilsan (30 m.) / Espiral Rilsan (30 m.)
6	41801902500A	Spirale Rilsan (5 spire) / Rilsan spiral (5 coils) / Spirale Rilsan (5 Windungen) / Spirale Rilsan (5 spires) / Espiral Rilsan (5 espire)
7	41451904300	Scheda madre / Motherboard / Hauptplatine / Carte mère / Tarjeta madre

<b>7</b>	<b>41451904300A</b>	Sensirion / Sensirion / Sensirion / Sensirion / Sensirion
<b>8</b>	<b>41451602802</b>	Pannello di emergenza Wireless / Wireless emergency display / Wireless Notfall-Blende / Panneau d'urgence wireless / Panel emergencia wireless
<b>9</b>	<b>41451801600</b>	Cavo flat 20 vie L.600 mm / Flat cable 20 pin L.600 mm / Flat-Kabel 20polig L.600 mm / Cable flat 20 voies L.600 mm / Flat cable 20 vias L.600 mm
<b>10</b>	<b>412007004</b>	Clickson 110°C / Clickson 110°C / Clickson 110°C / Clickson 110°C / Clickson 110°C
<b>11</b>	<b>41451003700</b>	Pressostato / Pressure switch / Druckschalter / Pressostat / Presostato
<b>12</b>	<b>41601301850</b>	Componente rilevamento portata aria / Air flow measure component / Bauteil für Messung der Luftmenge / Composent pour la mesuration de la quantité d'air / Componente por la medida de l'aire

## STREAM COMFORT AIR 12/12 UP! M1 - 2020 VERSION

Gruppo fumi / Smoke group / Rauchgruppe / Groupe fumées / Grupo de humos

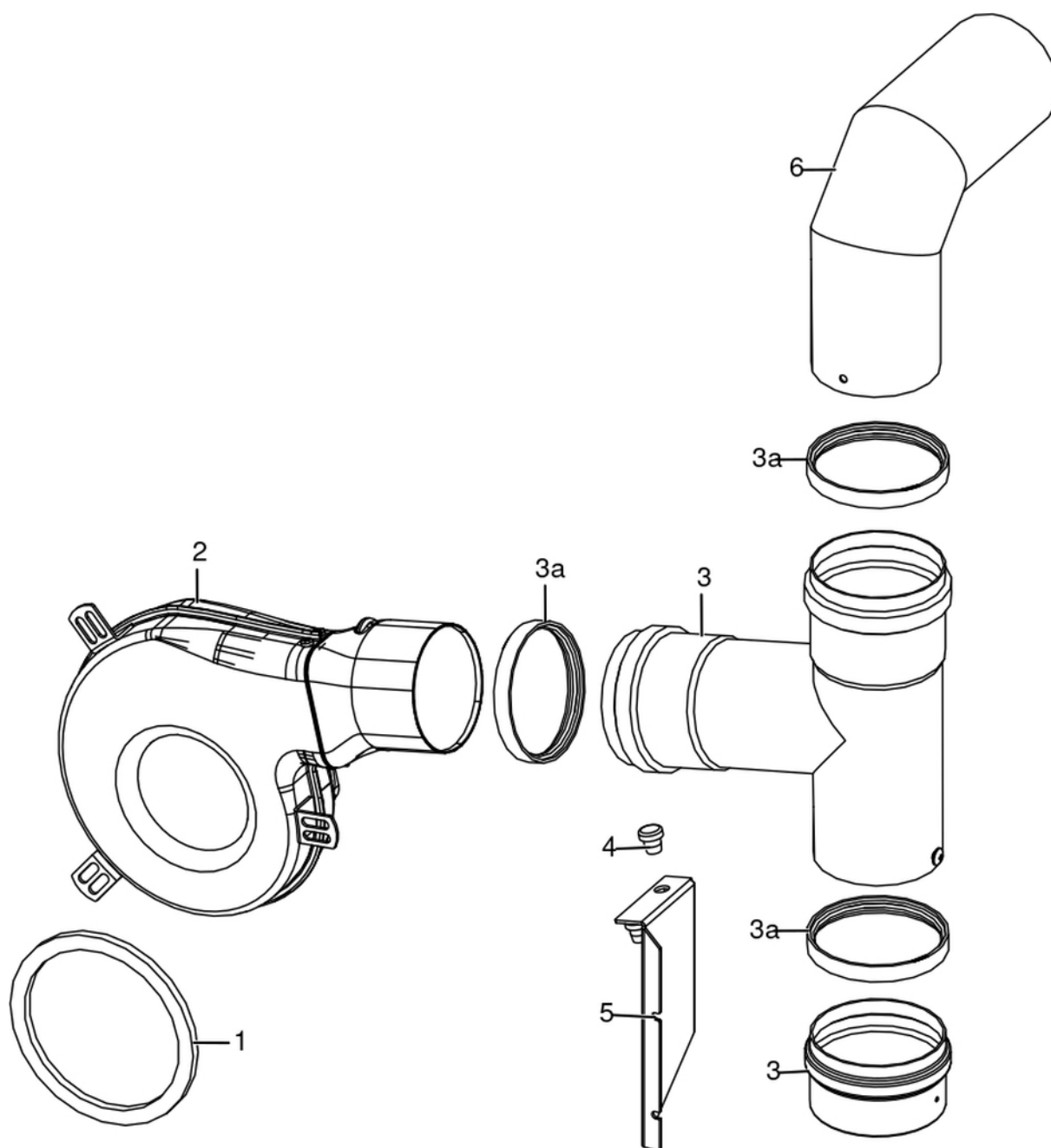

N°	Codice/Code	Descrizioni / Description / Beschreibung / Description / Description
1	41801002600	Guarnizione adesiva voluta fumi / Adhesive gasket smoke volute / Haftendichtung Rauchvolute / Joint adhesive volute fumées / Junta adhesiva voluta humos
1	41801599850	Kit 50 guarnizioni / Kit 50 gaskets / Bausatz 50 Dichtungen / Kit 50 joints / Kit 50 juntas
2	41451801800	Ventilatore fumi / Smoke exhaust fan / Rauchabsauggebläse / Ventilateur aspiration fumées / Ventilador aspiración de humos
3	41601805751	Tubo fumi F/F ad "Y" con guarnizione / "Y" F/F smoke pipe with gasket / "Y" F/F Rauchrohrmit Dichtung / Tuyau fumées "Y" F/F avec joint / Tubo humos "Y" F/F con junta
3a	40120969	Guarnizione silicone (5pz) / Silicone Gasket (5pc.) / Silikondichtung (5 St.) / Joint en silicone / Junta en silicona
4	4120180	Gommini paracolpi (4 pz) / Rubber bumpers (4 pcs.) / Schlagschutzgummi (4 Stck) / Pièces caoutchouc antichoc (4 pcs) / Cauchitos anti-golpes (4 pz)
5	41401823630	Staffa di supporto / Support bracket / Haltebügel / Étrier support / Abrazadera de soporte



6	4019002EA	Imballo curva / Curve packaging / Bogenverpackung / Emballage de courbe / Embalaje de curva
---	-----------	---

## STREAM COMFORT AIR 12/12 UP! M1 - 2020 VERSION

Gruppo fumi UP! / UP! Smoke group / UP! Rauchgruppe / Groupe fumées UP! / Grupo de humos UP!

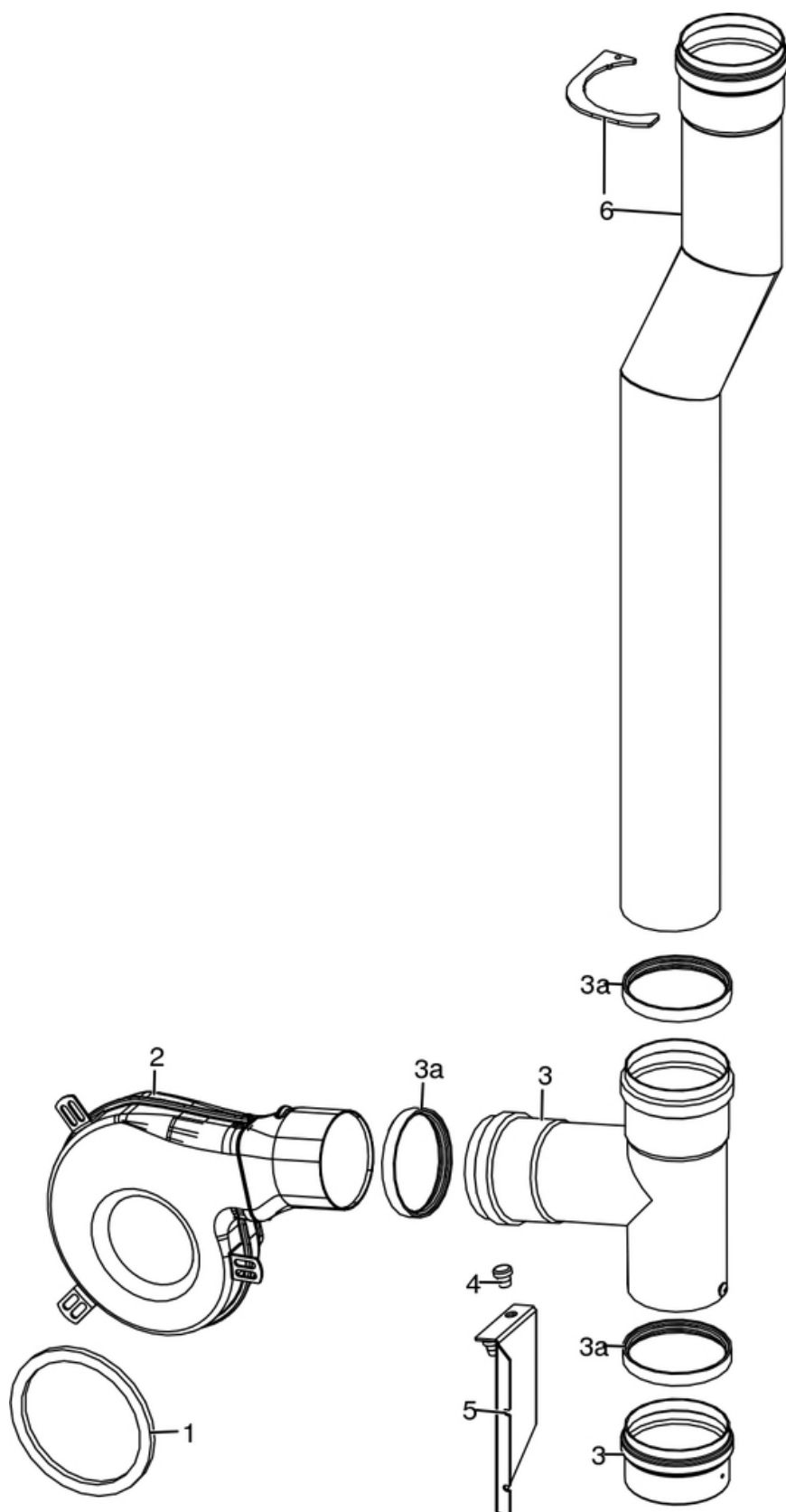

N°	Codice/Code	Descrizioni / Description / Beschreibung / Description / Descripción
1	41801002600	Guarnizione adesiva voluta fumi / Adhesive gasket smoke volute / Haftendichtung Rauchvolute / Joint adhesive volute fumées / Junta adhesiva voluta humos
1	41801599850	Kit 50 guarnizioni / Kit 50 gaskets / Bausatz 50 Dichtungen / Kit 50 joints / Kit 50 juntas
2	41451801800	Ventilatore fumi / Smoke exhaust fan / Rauchabsauggebläse / Ventilateur aspiration fumées / Ventilador aspiración de humos
3	41601805751	Tubo fumi F/F ad "Y" con guarnizione / "Y" F/F smoke pipe with gasket / "Y" F/F Rauchrohrmit Dichtung / Tuyau fumées "Y" F/F avec joint / Tubo humos "Y" F/F con junta
3a	40120969	Guarnizione silicone (5pz) / Silicone Gasket (5pc.) / Silikondichtung (5 St.) / Joint en silicone / Junta en silicona
4	4120180	Gommini paracolpi (4 pz) / Rubber bumpers (4 pcs.) / Schlagschutzgummi (4 Stck) / Pièces caoutchouc antichoc (4 pcs) / Cauchitos anti-golpes (4 pz)
5	41401823630	Staffa di supporto / Support bracket / Haltebügel / Étrier support / Abrazadera de soporte
6	4019001EA	Imballo tubo fumi / Smoke pipe packaging / Rauchrohrverpackung / Emballage du tuyau fumées / Embalaje tubo humos

## STREAM COMFORT AIR 12/12 UP! M1 - 2020 VERSION

Gruppo ventilazione / Ventilation group / Lüftungsgruppe / Groupe de ventilation / Grupo de ventilación

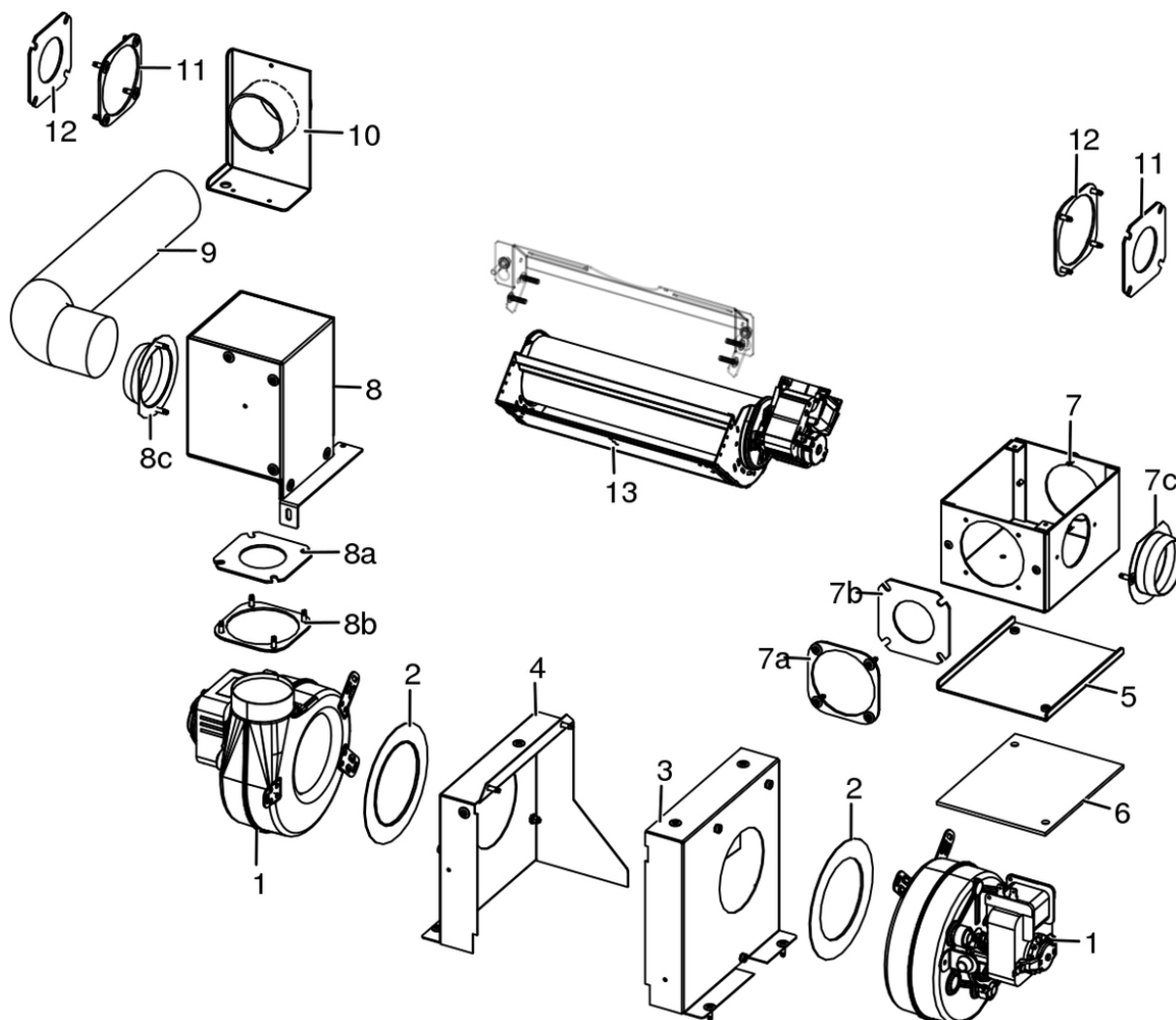

N°	Codice/Code	Descrizioni / Description / Beschreibung / Description / Descripción
1	41451402400	Ventilatore aria / Air fan / Luftgebläse / Ventilateur air / Ventilador aire
2	41801601600	Guarnizione ventilatore / Fan gasket / Dichtung des Gebläses / Joint du ventilateur / Junta ventilador
3	41401844131	Convogliatore destro / RH conveyor / Rechtes Blech / Convoyeur droit / Conductor derecho
4	41401824731	Convogliatore inferiore sinistro / LH low duct / linker untetere Förderer / Convoyeur gauche inférieur / Canalizador inferior izquierdo
5	41401843931	Coperchio scatola / Box cover / Schachtelabdeckung / Couvercle de coffret / Tapa de caja
6	41801901100	Guarnizione coperchio / Cover gasket / Deckel Dichtung / Joint couvercle / Junta tapa
7	41421900251	Convogliatore dx / RH Air conveyor / Luftblech Rechts / Convoyeur air droite / Conductor del aire DCHA
7a	41401843710	Piastra / Bracket / Bügel / Etrier / Abrazadera
7b	41801806700	Guarnizione / Gasket / Dichtung / Joint / Junta
7c	4011011	Flangia Ø 6 / Flange Ø 6 / Flansch Ø 6 / Bride Ø 6 / Brida Ø 6
8	41421900150	Convogliatore sx / LH Air conveyor / Luftblech Links / Convoyeur air gauche / Conductor del aire IZDA
8a	41401843710	Piastra / Bracket / Bügel / Etrier / Abrazadera
8b	41801806700	Guarnizione / Gasket / Dichtung / Joint / Junta
8c	4011011	Flangia Ø 6 / Flange Ø 6 / Flansch Ø 6 / Bride Ø 6 / Brida Ø 6
9	4009003	Tubo flessibile Ø 60 mm lunghezza 1,5 m / Flex pipe Ø 60 mm lenght 1,5 m / Schlauch Ø 60 mm Länge 1,5 m / Tuyau flexible Ø 60 mm longueur 1,5 m / Tubo flexible Ø 60 mm lunghezza 1,5 m
9	4009017	Tubo flessibile Ø 60 mm lunghezza 8 m / Flex pipe Ø 60 mm lenght 8 m / Schlauch Ø 60 mm Länge 8 m / Tuyau flexible Ø 60 mm longueur 8 m / Tubo flexible Ø 60 mm lunghezza 8 m

<b>10</b>	<b>4140185034000</b>	Flangia completa nera / Complete black Flange / Kompletter schwarze Flansch / Bride noire complète / Brida negra completa
<b>11</b>	<b>41401843710</b>	Piastra / Bracket / Bügel / Etrier / Abrazadera
<b>12</b>	<b>41801806700</b>	Guarnizione / Gasket / Dichtung / Joint / Junta
<b>13</b>	<b>41451600800</b>	Ventilatore aria / Air fan / Luftgebläse / Ventilateur air / Ventilador aire