

SUITE COMFORT AIR MATIC 14 M1

Rivestimento / Cladding / Verkleidung / Habillage / Revestimiento

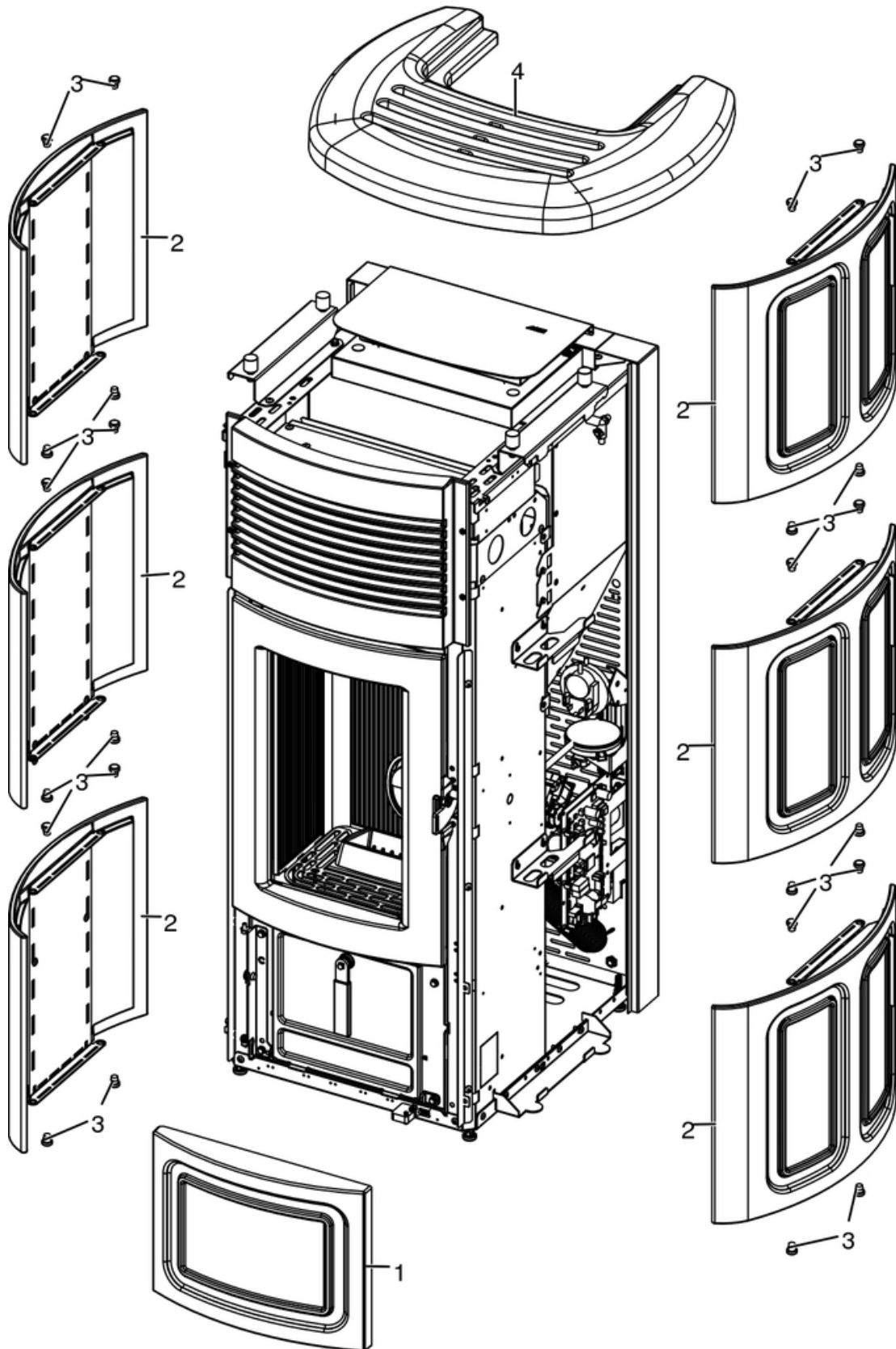

N°	Codice/Code	Descrizioni / Description / Beschreibung / Description / Descripción
1	41251602750	Ceramica inferiore completa Sale&Pepe / Complete salt and pepper lower ceramic / Komplette untere Keramik Salz und Pfeffer / Carreaux inférieurs en céramique poivre et sel complète / Cerámica inferior sal y pimenta completa
1	41251602850	Ceramica inferiore completa Old Amber / Complete lower ceramic OLD AMBER / Komplette untere Keramik OLD AMBER / Carreaux inférieurs en céramique OLD AMBER complète / Cerámica inferior OLD AMBER completa
1	41251602950	Ceramica inferiore completa Bordeaux / Complete lower ceramic BORDEAUX / Komplette untere Keramik BORDEAUX / Carreaux inférieurs en céramique BORDEAUX complète / Cerámica inferior BORDEAUX completa
2	41251405050	Ceramica laterale Salt and Pepper / Salt and Pepper lateral ceramic / Seitliche Keramik Salt and Pepper / Céramique latérale Salt and Pepper / Cerámica laterale Salt and Pepper
2	41251405150	Ceramica laterale Old Amber / Old Amber lateral ceramic / Seitliche Keramik Old Amber / Céramique latérale Old Amber / Cerámica laterale Old Amber
2	41251403850	Ceramica laterale Bordeaux / Bordeaux lateral ceramic / Seitliche Keramik Bordeaux / Céramique latérale Bordeaux / Cerámica laterale Bordeaux
3	4120180	Gommini paracolpi (4 pz) / Rubber bumpers (4 pcs.) / Schlagschutzgummi (4 Stck) / Pièces caoutchouc antichoc (4 pcs) / Cauchitos anti-golpes (4 pz)
4	41251404660	Top in ceramica Salt and Pepper / Salt and Pepper ceramic top / Keramiktop Salt and Pepper / Dessus en céramique Salt and Pepper / Top en cerámica Salt and Pepper
4	41251404760	Top in ceramica Old Amber / Old Amber ceramic top / Keramiktop Old Amber / Dessus en céramique Old Amber / Top en cerámica Old Amber
4	41251403360	Top in ceramica Bordeaux / Bordeaux ceramic top / Keramiktop Bordeaux / Dessus en céramique Bordeaux / Top en cerámica Bordeaux

SUITE COMFORT AIR MATIC 14 M1

Gruppo estetico / Aesthetic group / Aesthetische Gruppe / Groupe esthétique / Grupo estético

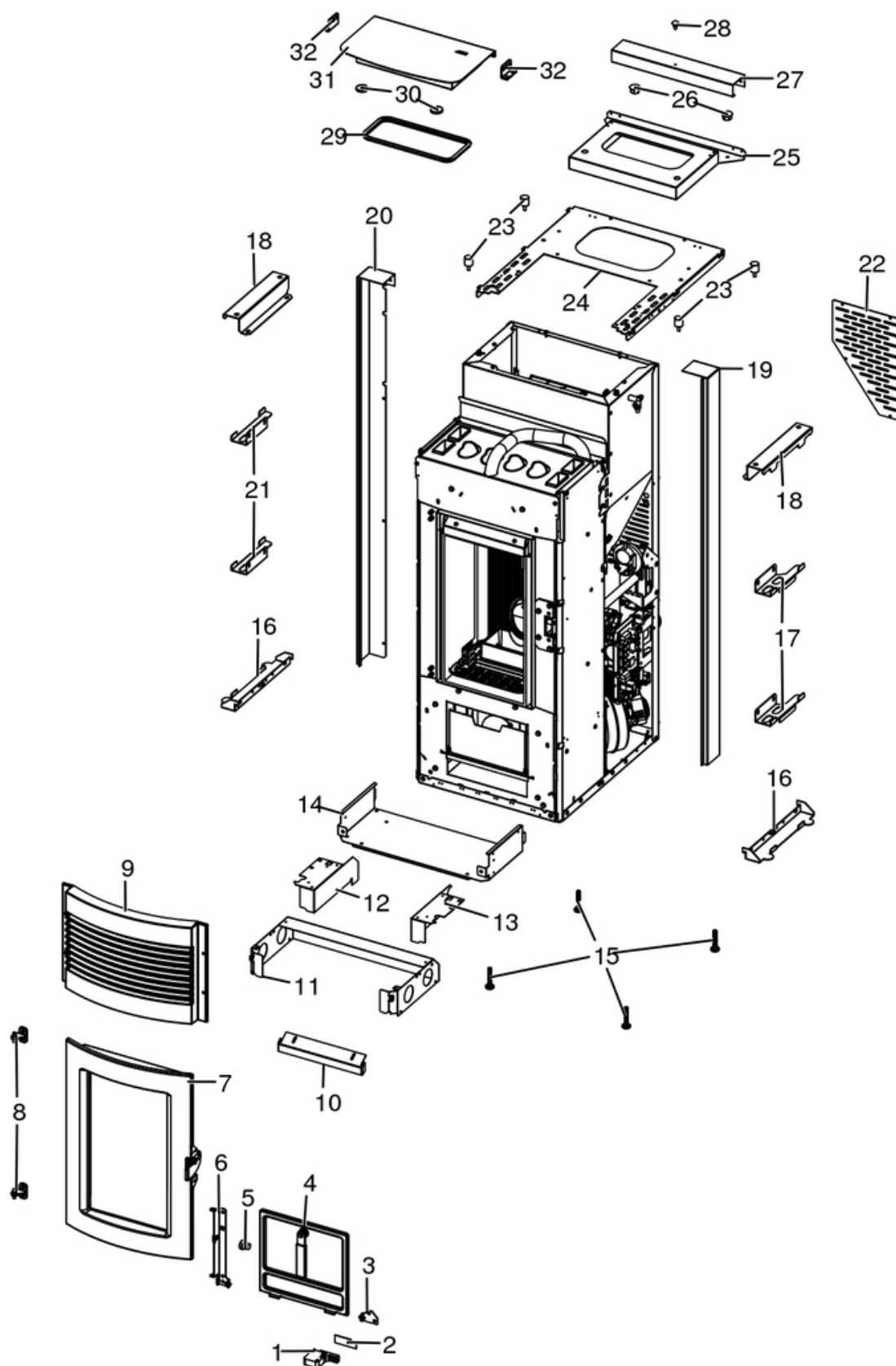

N°	Codice/Code	Descrizioni / Description / Beschreibung / Description / Descripcion
1	41201305100	Chiusura a spinta / Push-pull pressure closing / Druckschließung / Fermeture par pression / Cierre a presión
2	41801607300	Guarnizione scroccchetto / Latch gasket / Riegel Dichtung / Joint loquet / Burlete pestillo
3	41411674540V	Supporto sportello cenere / Ash drawer support / Aschenkasten Stütze / Support tiroir à cendres / Soporte Cajón ceniza
4	437016130	Porta cenere con maniglia / Ash drawer door with handle / Tür des Aschenkastens mit Griff / Porte tiroir à cendres avec poignée / Puerta cajón ceniza con tirador
5	4120180	Gommini paracolpi (4 pz) / Rubber bumpers (4 pcs.) / Schlagschutzgummi (4 Stck) / Pièces caoutchouc antichoc (4 pcs) / Cauchitos anti-golpes (4 pz)
6	41411670640V	Supporto ceramica inferiore / Lower ceramic support frame / Unterer Keramikbügel / Support inférieur pour ceramique / Soporte inferior cerámicas
7	437016208	Porta / door / Tür / Porte / Puerta
8	41201504460	Cerniera porta (2 pz.) / Door hinge (2 pc.) / Tür Scharnier (2 Stk.) / Charnière porte (2 pc.) / Bisagra puerta (2)
9	41301503200V	Griglia aria superiore in ghisa / Upper cast iron air grille / Obere Luftgitter aus Guß / Grille air supérieur en fonte / Rejilla aire superior de arrabio
10	41411615430V	Deflettore aria / Air deflector / Luftleitblech / Déflecteur aire / Deflector aire
11	41401721830	Convogliatore / Conveyor / Blech / Convoyeur / Conductor
12	41401626131V	Tamponazione sx / L. filling / Abdichtung L. / Tampon G. / Taponado IZDO
13	41401626031V	Tamponazione dx / R. filling / Abdichtung R. / Tampon D. / Taponado DCHO
14	41401626232V	Compensatore / Compensator / Kompensator / Compensateur / Compensador
15	41200906660	Piedini di appoggio (4 pz.) / Support feet (4 pcs.) / Einstellfüße (4 Stck.) / Vérins d'appui (4 p.es) / Pies de apoyo (4 piezas)
16	41401629730	Supporto / Support / Stütze / Support / Soporte
17	41401703730	Fermo dx fianco ceramica / Ceramic R. side stop / Keramikträger Seiten R. Stopper / Stop côté en céramique D. / Stop lado DCHO ceramica
18	41401430630	Staffa superiore fissaggio ceramica laterale / Upper fastening bracket for lateral ceramic / Obere Befestigungsbügel für seitliche Keramik / Etrier supérieure de fixation céramique latérale / Estribo superior de fijación cerámica laterale
19	41411676230P	Spalla dx / R. Pillar / R. Säule / Pilier D. / Pilar DCHO
20	41411676330P	Spalla dx / R. Pillar / R. Säule / Pilier D. / Pilar DCHO
21	41401703830	Fermo sx fianco ceramica / Ceramic L. side stop / Keramikträger Seiten L. Stopper / Stop côté en céramique G. / Stop IZDO lado ceramica
22	41401902010	Coperchio posteriore / Rear cover / Hinterer Deckel / Couvercle postérieur / Tapadera posterior
23	41201105600	Antivibranti (10 pz) / anti-vibration mountings (10 pcs) / Schwingungsdämpfer (10 Stck) / Éléments antivibratoires (10 pcs) / Anti-vibraciones (10 pz)
24	41401820630	Supporto top / Top support / Deckelhaltebügel / Support du dessus / Soporte top
25	41401820730	Tamponazione serbatoio / Filling Rear / Abdichtung Rückwand / Tampon réservoir / Taponado depósito
26	41801802200	Tappo plastica / Plastic cap / Kunststoff Verschluss / Bouchon plastique / Tapón en plástico
27	4141187683000	Profilo posteriore / Rear profile / Hinteres Profil / Profil postérieur / Perfil trasero
28	41801002300	Paracolpi in silicone Ø 8/5 (2pz) / Silicone bumpers Ø 8/5 (2pcs) / Schlagschutzgummi Ø 8/5 (2 Stck) / Pièces silicone antichoc Ø 8/5 (2pcs) / Anti-golpes en silicona Ø 8/5 (2pzs)
29	41801601400	Guarnizione coperchio serbatoio / Pellet hopper cover gasket / Deckel Pelletbehälter Dichtung / Joint couvercle réservoir pellet / Junta tapa depósito pellet
30	41801657900	Magneti (pz.2) / Magnet (pcs.2) / Magnet (stk. 2) / Aimant (pcs.2) / Imán (pz.2)
31	4141187674000	Coperchio / Cover / Deckel / Couvercle / Tapa
31	41801701400	Logo MCZ / MCZ logo / MCZ logo / MCZ logo / MCZ logo
32	4141187713000	Cerniera coperchio / Cover hinge / Abdeckscharnier / Charnière couvercle / Bisagra de la tapa

SUITE COMFORT AIR MATIC 14 M1

Gruppo camera di combustione / Combustion chamber group / Verbrennungskammer Gruppe / Group de chambre de combustion / Grupo cámara de combustión

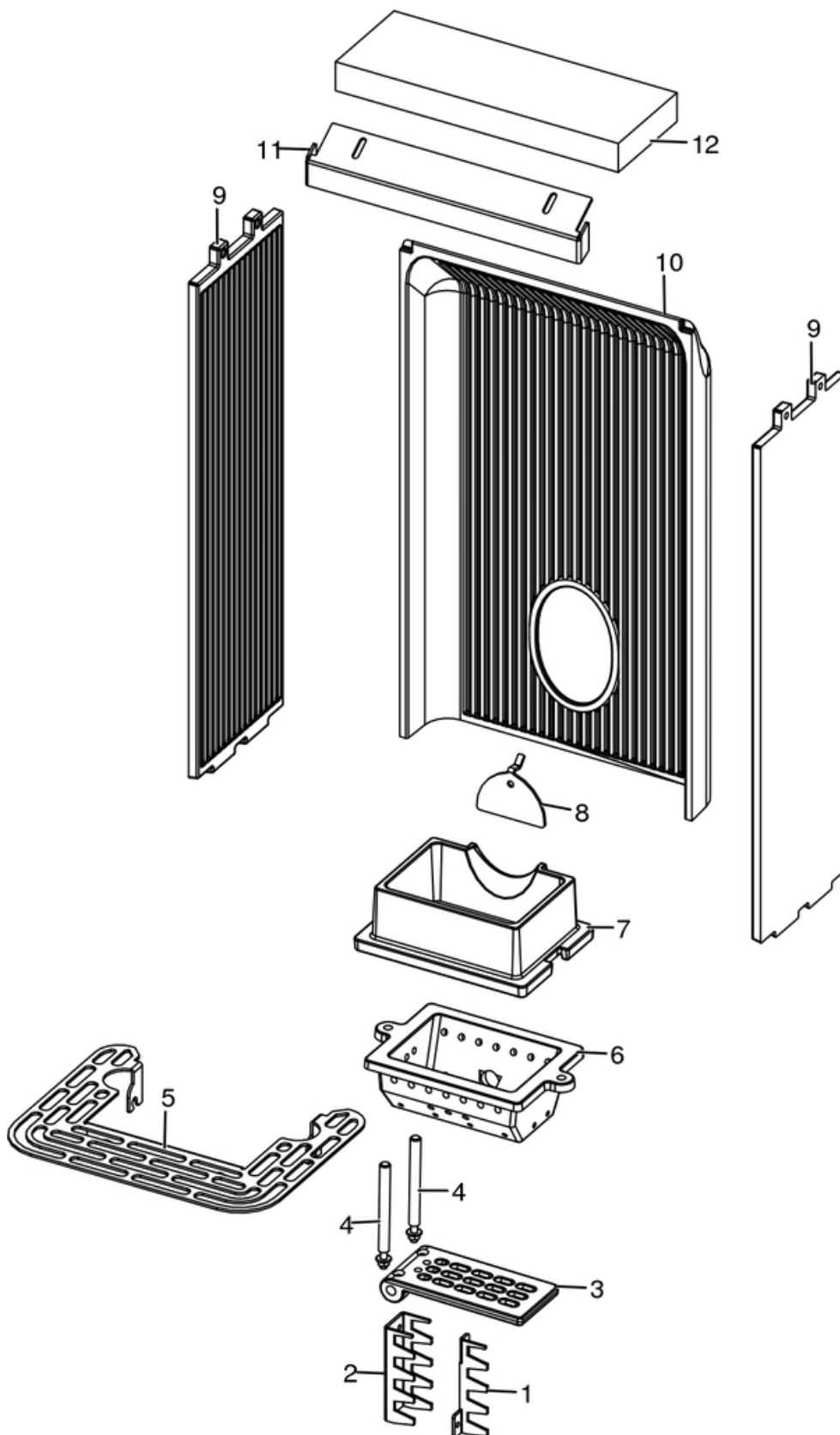

N°	Codice/Code	Descrizioni / Description / Beschreibung / Description / Descripcion
1	41401902330	Pettine / Comb / Kamm / Peigne / Peine
2	41401916730	Pettine / Scraper / Kratzer / Racleur / Raspador
3	4130180110000	Base braciere / Combustion pot basement / Untergestell Brennschale / Base du brasero / Base brasero
4	41201601400	Perno fondo braciere autopulente (pz.2) / Self-cleaning cast iron bottom grate pin (Pcs.2) / Selbstreinigend Brennertopf aus Gusseisen Bolzen Boden (Stk.2) / Pivot fond brasero en fonte autonettoyant (Pcs.2) / Perno fondo brasero en arrabio autolimpiador (Pz.2)
5	4141194704000	Griglia focolare / Grille / Rost / Grille / Rejilla
6	4130180100000	Braciere inferiore / Lower combustion pot / Untere Brennschale / Brasero inférieur / Brasero inferior
7	4130190150000	Braciere superiore / Upper combustion pot / Obere Brennschale / Brasero supérieur / Brasero superior
8	41411613530V	Deflettore pellet / Pellet deflector / Pellet Leitblech / Deflecteur pellet / Deflector pellet
9	41301502500V	Fianco ghisa / Cast iron side / Seite aus Guß / Côté en fonte / Placa lateral de arrabio
10	41301502600V	Schiena ghisa / Cast iron back / Rückwand aus Gusseisen / Dossieret en fonte / Parte trasera en arrabio
11	41411615430V	Deflettore aria / Air deflector / Luftleitblech / Déflecteur aire / Deflector aire
12	41151600200	Deflettore focolare in vermiculite / Vermiculite deflector / Leitblech aus Vermiculite / Déflecteur en vermiculite / Deflector en vermiculite

SUITE COMFORT AIR MATIC 14 M1

Porta fuoco / Fire door / Feuertür / Porte foyer / Puerta hogar

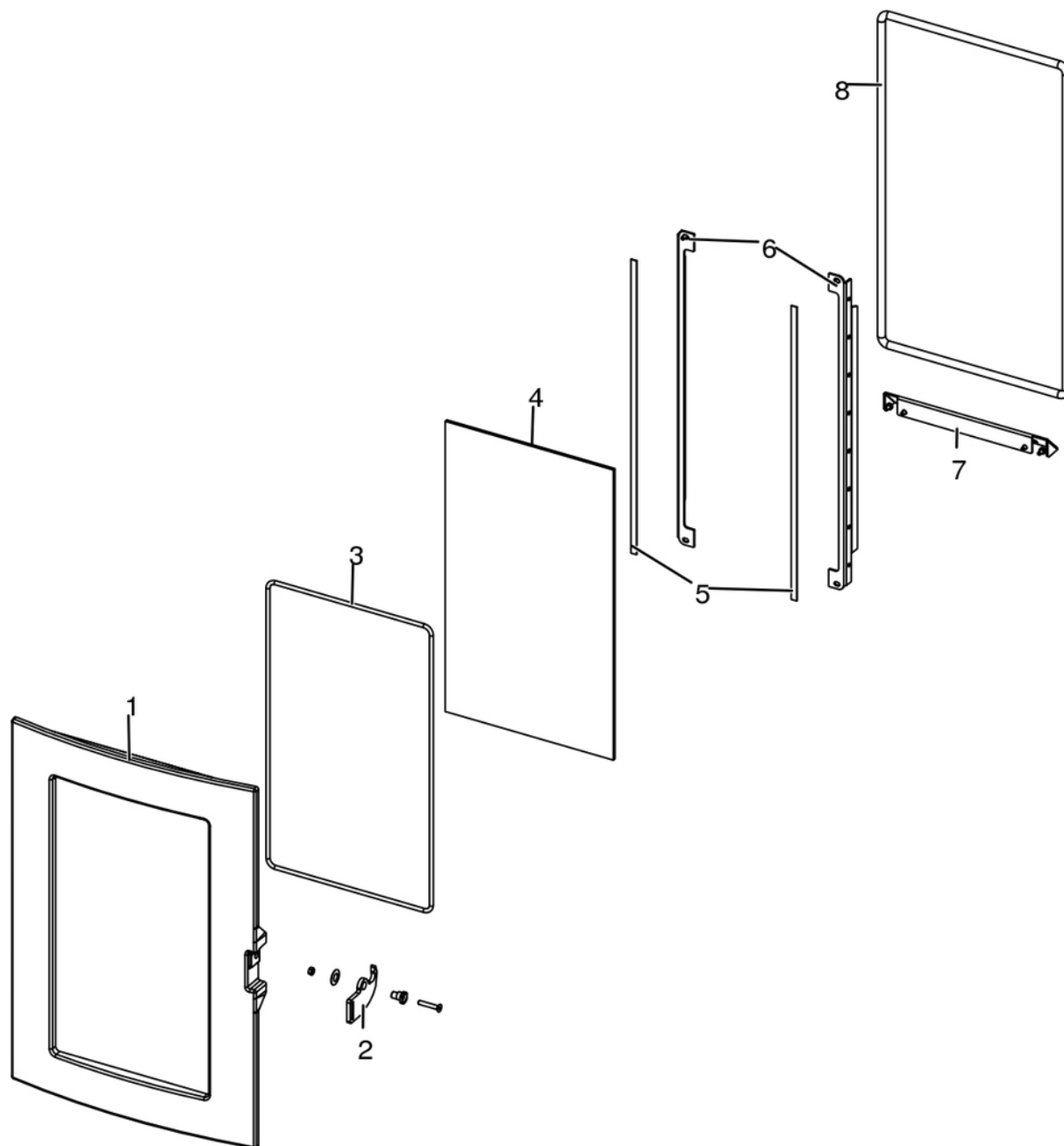

N°	Codice/Code	Descrizioni / Description / Beschreibung / Description / Descripción
1	41301600500V	Telaio porta fuoco in ghisa / Cast iron fire door frame / Feuertürrahment aus Guß / Cadre porte foyer en fonte / Armazón puerta hogar de arrabio
2	41401424160	Maniglia completa / Complete handle / Kompletter Griff / Poignée complète / Tirador completo
3	41801603300A	Guarnizione Ø5 5mt / Gasket Ø5 5mt / Dichtung Ø5 5mt / Joint Ø5 5mt / Junta Ø5 5mt
3	41801603300B	Guarnizione Ø5 50mt / Gasket Ø5 50mt / Dichtung Ø5 50mt / Joint Ø5 50mt / Junta Ø5 50mt
3	41801603300C	Guarnizione Ø5 5mt + silicone / Gasket Ø5 5mt + silic / Dichtung Ø5 5mt + Silikon / Joint Ø5 5mt + silic / Junta Ø5 5mt
4	41701600300	Vetroceramico porta ghisa / Cast iron door glass / Glaskeramikscheibe Tür aus Gusseise / Vitrocéremique porte en fonte / Cristal cerámico puerta en arrabio
5	4120573A	Guarnizione a nastro 8 mm (5 mt.) per porta / Door strip gasket 8 mm (5 m) / Türbanddichtung 8 mm (5 m) / Joint ruban 8 mm (5 m) pour porte / Guarnición de cinta para puerta 8 mm (5 m)
5	4120573B	Guarnizione a nastro 8 mm (50 mt.) per porta / Door strip gasket 8 mm (50 m) / Türbanddichtung 8 mm (50 m) / Joint

		ruban 8 mm (50 m) pour porte / Guarnición de cinta para puerta 8 mm (50 m)
6	41411622030V	Profilo fermavetro / Fastening bracket profile / Haltebügel für Scheibebefestigung Profil / Profil patte de fixation / Perfil fermacristal
7	41411622130V	Scivolo cenere / Ash ramp / Aschenrutsche / Glissèrie cendre / Tobogán ceniza
8	4120104A	Cordino fibrocaramico Ø 12 mm (5 mt.) / Ceramic fibre cord Ø 12 mm (5 m.) / Keramikfaserschnur Ø 12 mm (5 m) / Cordon en fibre céramique Ø 12 mm (5 m) / Junta a cuerda de fibra cerámica Ø 12 mm (5 m)
8	4120104B	Cordino fibrocaramico Ø 12 mm (50 mt.) / Ceramic fibre cord Ø 12 mm (50 m.) / Keramikfaserschnur Ø 12 mm (50 m) / Cordon en fibre céramique Ø 12 mm (50 m) / Junta a cuerda de fibra cerámica Ø 10 mm (52 m)
8	41201041	Kit sostituzione cordino (cordino+silicone) Ø 12 mm / Cord replacement kit (cord + silicon) Ø 12 mm / Schnuraustauschsatz (Schnur+Silikon) Ø 12 mm / Kit remplacement cordon (cordon + silicone) Ø 12 mm / Kit sustitución junta a cuerda (junta a cuerda+silicón) Ø 12 mm

SUITE COMFORT AIR MATIC 14 M1

Porta cenere / Ash door / Ashentür / Porte cendre / Puerta ceniza

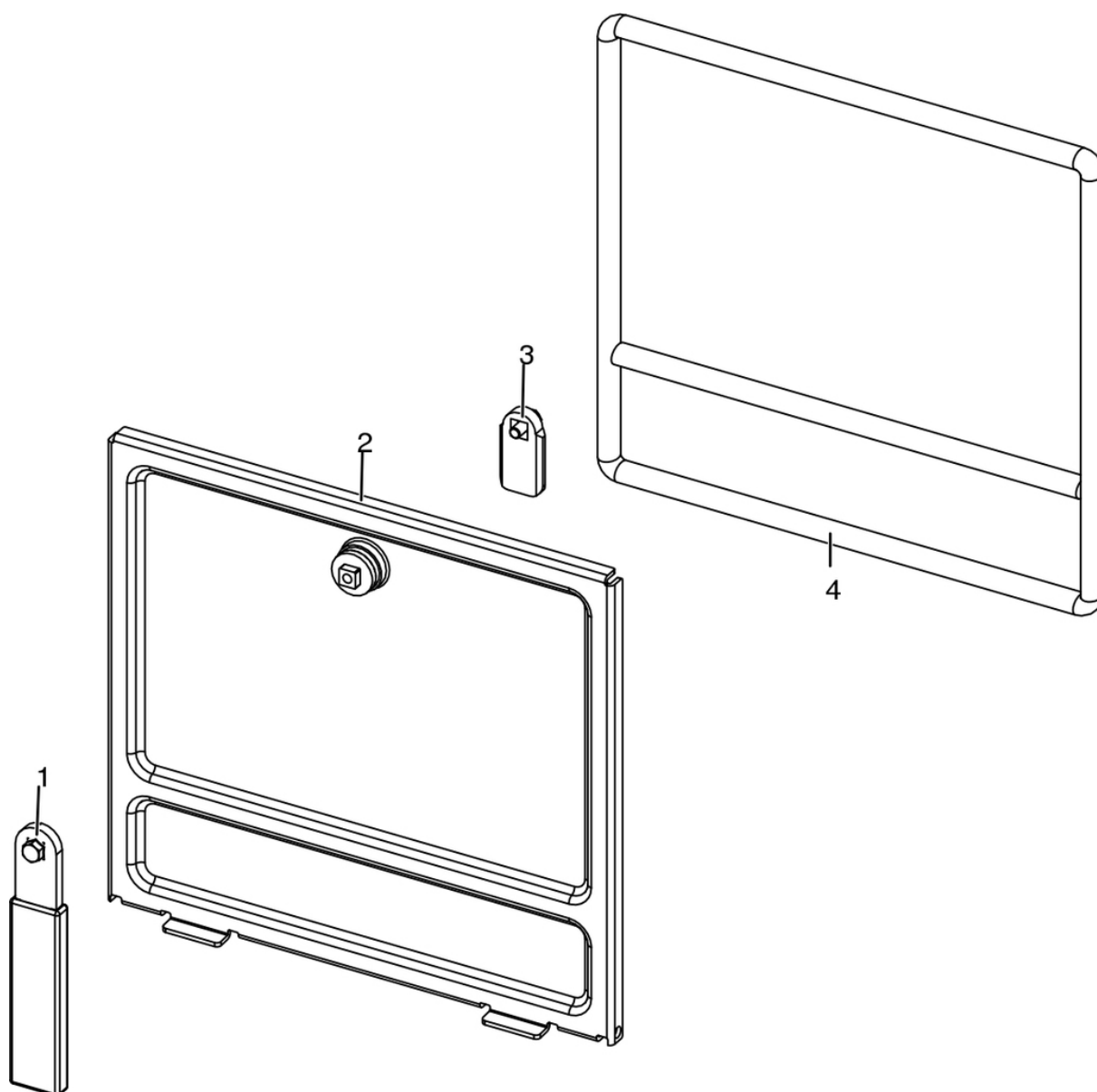

N°	Codice/Code	Descrizioni / Description / Beschreibung / Description / Descripción
1	41411621600	Maniglia con impugnatura porta cenere / Handle / Griff / Poignée / Tirador
2	41421602141V	Porta cenere / Ash drawer door / Tür des Aschenkastens / Porte tiroir à cendres / Puerta cajón ceniza
3	41201608400	Serratura porta cassetto cenere / Door lock for ash drawer / Türschloss für Aschenkasten / Serrure de porte du tiroir à cendres / Cerradura puerta cajón ceniza
4	412007003A	Cordino fibroceramico Ø 14 mm (5 mt.) / Ceramic fibre cord Ø 14 mm (5 m.) / Keramikfaserschnur Ø 14 mm (5 m) / Cordon en fibre céramique Ø 14 mm (5 m) / Junta a cuerda de fibra cerámica Ø 14 mm (5 m)
4	412007003B	Cordino fibroceramico Ø 14 mm (50 mt.) / Ceramic fibre cord Ø 14 mm (50 m.) / Keramikfaserschnur Ø 14 mm (50 m) / Cordon en fibre céramique Ø 14 mm (50 m) / Junta a cuerda de fibra cerámica Ø 14 mm (50 m)
4	412007003C	Kit sostituzione cordino (cordino+silicone) Ø 14 mm / Cord replacement kit (cord + silicon) Ø14 mm / Schnuraustauschsatz (Schnur +Silikon) Ø 14 mm / Kit remplacement cordon (cordon+silicon) Ø 14 / Kit sustitución junta a cuerda (junta a cuerda+silicón) Ø 14 mm

SUITE COMFORT AIR MATIC 14 M1

Gruppo caricamento pellet / Pellet feed group / Pellet Fördergruppe / Groupe chargement du pellet / Grupo de carga pellet

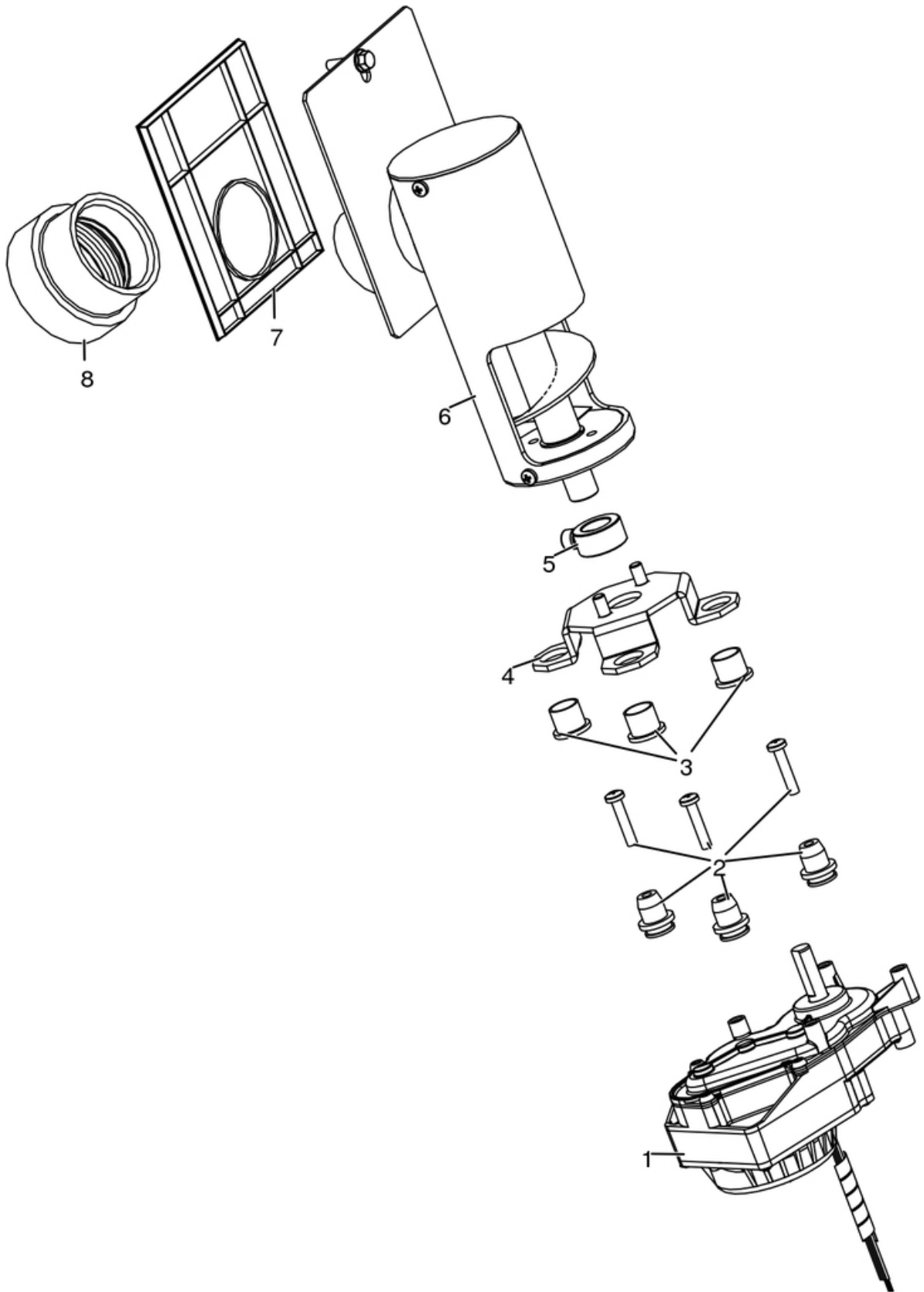

N°	Codice/Code	Descrizioni / Description / Beschreibung / Description / Descripción
1	41451702200	Motoriduttore brushless / Brushless reduction motor / Brushless Getriebemotor / Motoréducteur brushless / Motorreductor brushless
2	41801703700	Gommini antivibrante / Vibration damper rubber / Rammschutz Gummi / Caoutchouc antivibratoire / Cauchitos antivibración
3	41201800700	Boccola (3 pz) / Bushing (3 pcs) / Buchse (3 Stk) / Douille (3 pcs) / Abrazadera (3 pzs)
4	41411779331	Supporto coclea "Ragno" / Pellet feed screw bracket "spider" / "Spinne" Schenke Gestell / Support vis sans fin "Araignée" / Soporte coclea "Araña"
5	4120398	Connettore motoriduttore-coclea / Reduction motor-feed screw connector / Verbindung Getriebemotor-Schnecke / Connecteur motoréducteur-vis sans fin / Conector motorreductor-cóclea
6	41411800151	Gruppo alimentazione completo / Complete feed screw / Komplette Förderschnecke / Vis sans fin complète / Coclea de carga completa
7	41801600400	Guarnizione gruppo caricamento / Gasket / Dichtung / Joint / Junta
8	41801702600	Disaccoppiatore mesc. Marrone / Brown disengaging device / Braun Verängungsrohr / Tuyau de découplage maron / Tubo de desvío marron

SUITE COMFORT AIR MATIC 14 M1

Gruppo accensione / Ignition group / Entzündung Gruppe / Groupe d'allumage / Grupo ignición

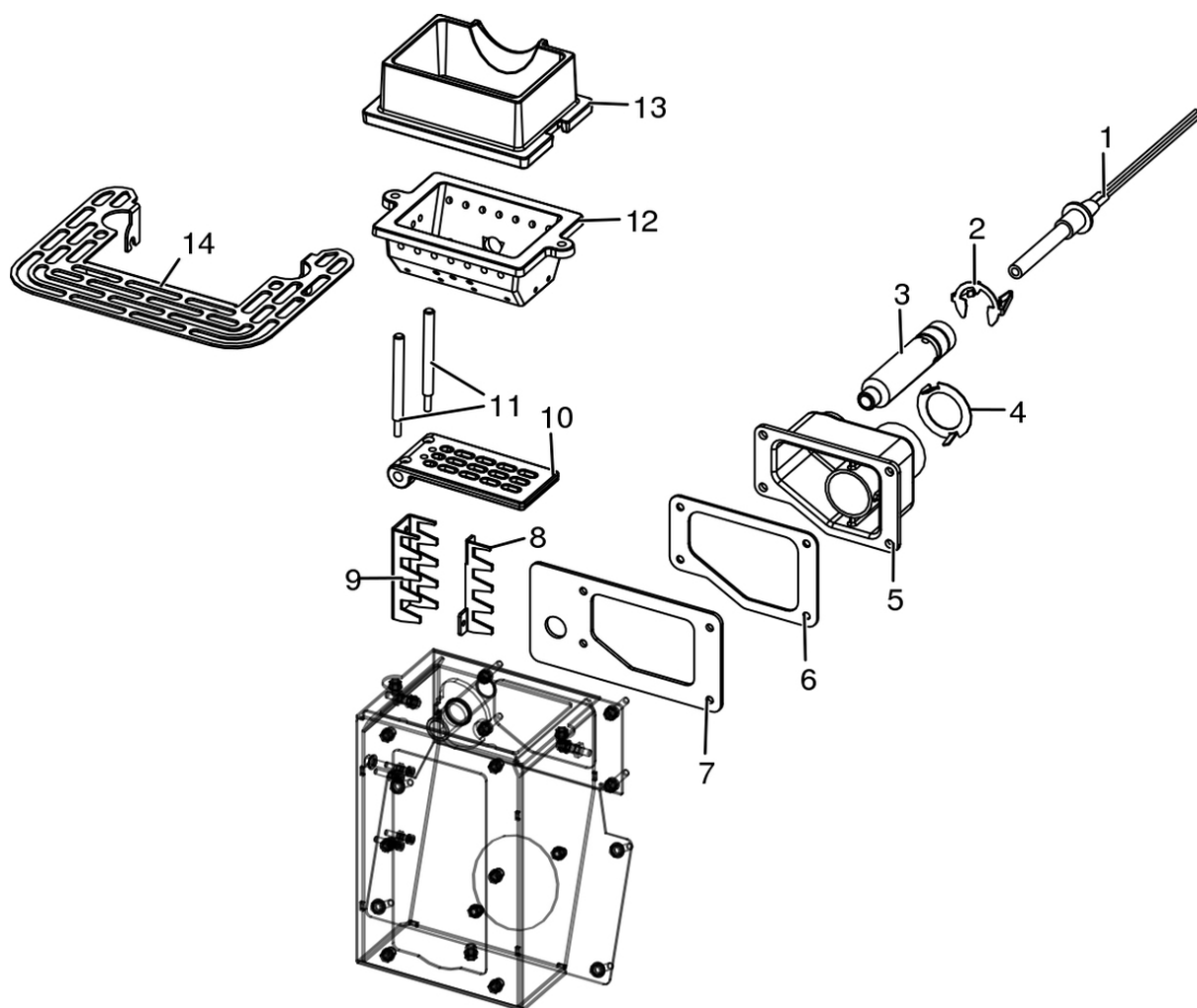

N°	Codice/Code	Descrizioni / Description / Beschreibung / Description / Descripción
1	41451308101	Candeletta 315 Watt / Sparkplug 315 Watt / Zündkerze 315 Watt / Bougie 315 Watt / Bujía 315 Watt
1	41451308150	Kit 25 candelette 315 Watt / 25 Sparkplugs 315 Watt kit / Bausatz 25 Zündkerzen 315 Watt / Kit 25 Bougies 315 Watt / Kit 25 Bujías 315 Watt
2	41201601500	Anello arresto candeletta / Sparkplug stop / Zündkerzestopper / Butée bougie / Tope bujía
3	41601601000	Condotto candeletta / Sparkplug Conduit / Zündkerzenkanal / Conduit Bougie / Conducto Bujía
4	41401629410	Regolatore ingresso aria comburente / Combustion air intake adjuster / Regler Eingang Verbrennungsluft / Régulateur arrivée air comburant / Regulador entrada aire comburente
5	41311600100	Codolo / Tool chuck / Einspannschaft / Outil d'emmanchement / Mango
5	41501701599	Manicotto potenziamento accensione / Combustion air extension pipe / Zusatzrohr für Nachrüstung / Tuyau amélioration allumage / Tubo impulso de encendido
5	41311803500	Codolo / Tool chuck / Einspannschaft / Outil d'emmanchement / Mango
6	41801602300	Guarnizione codolo / Gasket / Dichtung / Joint / Junta
7	41801904400	Guarnizione tasca braciere / Combustion pot container gasket / Brenntopfkasten Dichtung / Joint récipient brasero / Junta contenidor brasero
8	41401902330	Pettine / Comb / Kamm / Peigne / Peine
9	41401916730	Pettine / Scraper / Kratzer / Racleur / Raspador
10	4130180110000	Base braciere / Combustion pot basement / Untergestell Brennschale / Base du brasero / Base brasero
11	41201601400	Perno fondo braciere autopulente (pz.2) / Self-cleaning cast iron bottom grate pin (Pcs.2) / Selbstreinigend Brenntopf aus Gusseisen Bolzen Boden (Stk.2) / Pivot fond brasero en fonte autonettoyant (Pcs.2) / Perno fondo brasero en arrabio autolimpiador (Pz.2)

12	4130180100000	Braciere inferiore / Lower combustion pot / Untere Brennschale / Brasero inférieur / Brasero inferior
13	4130190150000	Braciere superiore / Upper combustion pot / Obere Brennschale / Brasero supérieur / Brasero superior
14	4141194704000	Griglia focolare / Grille / Rost / Grille / Rejilla

SUITE COMFORT AIR MATIC 14 M1

Gruppo aria comburente / Combustion air group / Verbrennungsluft Gruppe / Groupe air comburant / Grupo aire comburente

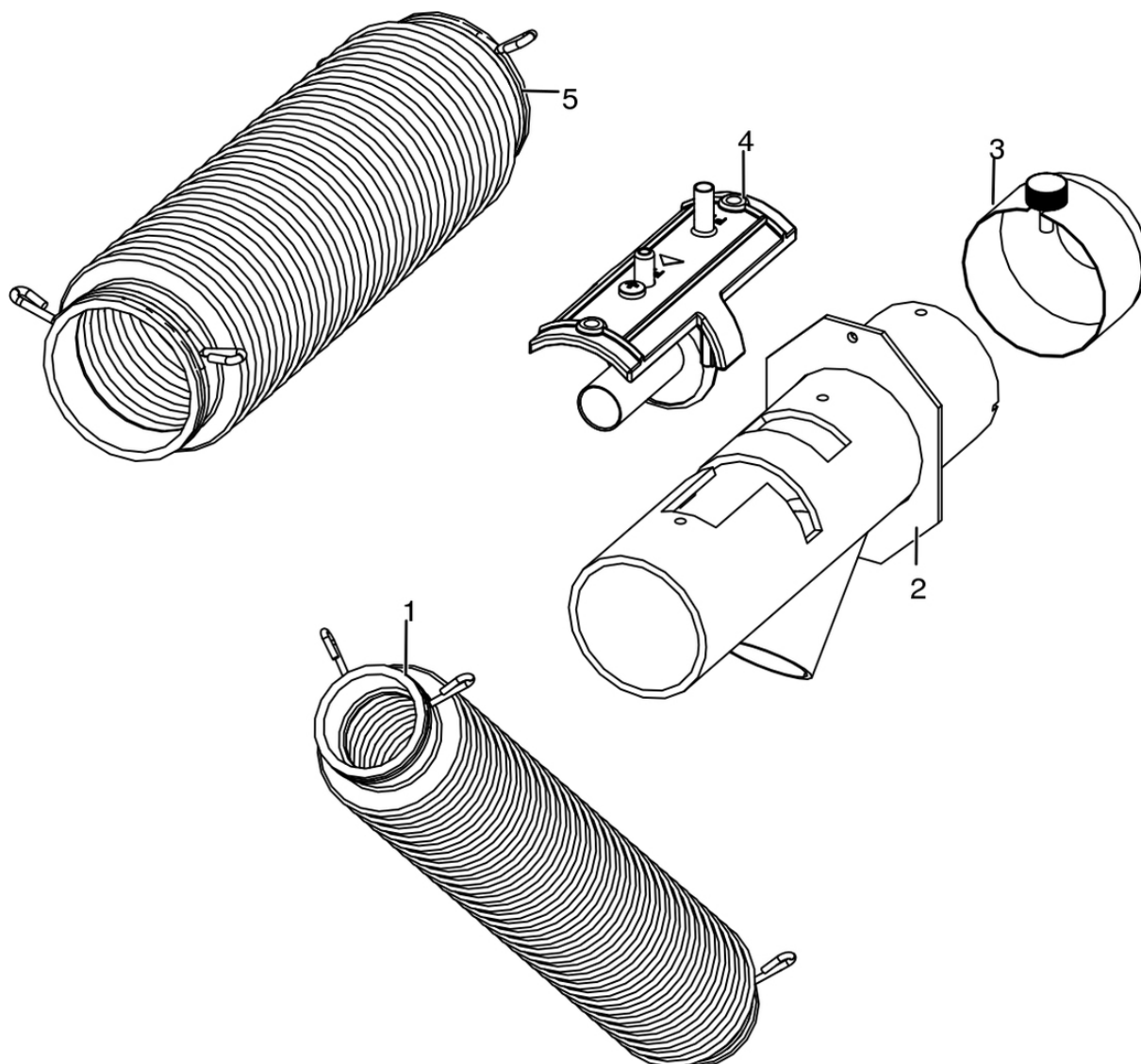

N°	Codice/Code	Descrizioni / Description / Beschreibung / Description / Descripción
1	41801601900	Tubo aspirazione pulizia vetro / Inlet pipe for cleaning glass air / Glassreinigungs Lufteingangrohr / Tuyau entrée pour l'aire de nettoyage du vitre / Tubo entrada por l'aire de limpieza vidrio
2	41601604461	Tubo aspirazione / Air inlet pipe / Lufteingangrohr / Tuyau entrée d'air / Tubo entrada aire
3	41401036100	Filtro antipolvere / Anti-dust filter / Staubschutzfilter / Filtre antipoussière / Filtro de protección polvo
4	41601301850	Componente rilevamento portata aria / Air flow measure component / Bauteil für Messung der Luftmenge / Composent pour la mesuration de la quantité d'air / Componente por la medida de l'aire
5	41801601700	Tubo aspirazione camera combustione / Combustion chamber aspiration tube / Verbrennungskammer Förderrohr / Tuyau aspiration air chambre de combustion / Tubo aspiración aire cámara de combustión

SUITE COMFORT AIR MATIC 14 M1

Gruppo elettrico ed elettronico / Electrical and electronic group / Elektrische und elektronische Gruppe / Groupe électrique et électronique / Grupo eléctrico y electrónico

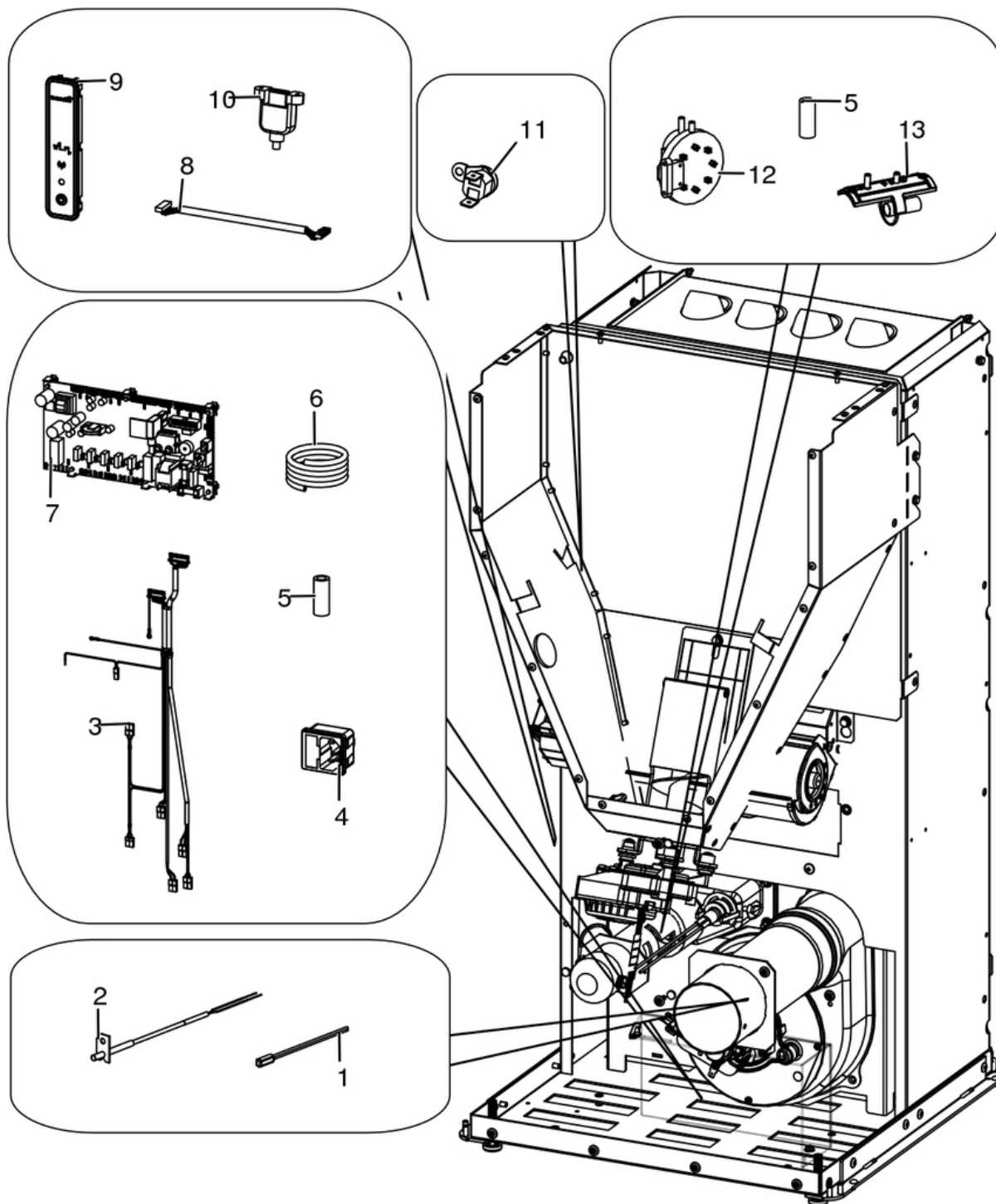

N°	Codice/Code	Descrizioni / Description / Beschreibung / Description / Description
1	4160386	Sonda temperatura ambiente/acqua / Room/Water temperature sensor / Raum- Wassertemperaturfühler / Sonde température ambiance/eau / Sonda temperatura ambiente/agua
2	41451703600	Sonda fumi con flangia con morsetteria L.980 / Smoke sensor with flange with terminal board L.980 / Rauchsonde mit Flansche mit Klemmenbrett L.980 / Sonde fumées avec bride avec serre-câble L.980 / Sonda humos con brida con borne L.980
3	41451905000	Cablaggio / Wiring / Verkabelung / Câblage / Cableado

3	41451603900	Cablaggio terzo ventilatore / Wiring third fan / Verkabelung dritte Gebläse / Câblage troisième ventilateur / Cableado tercero ventilador
3	41451803550	Kit cablaggi messa a terra / Grounding wiring kit / Erdungskabelbaum / Kit mise à terre / Kit cableado a tierra
4	41451104100	Presa con fusibile / Socket with fuse / Steckdose mit Sicherung / Prise avec fusible / Toma con fusible
5	4120631A	Tubicino siliconico - 5m / Silicon tube - 5m / Silikonrohr - 5m / Petit tuyau en silicone - 5m / Tubo silicónico - 5m
6	41801902500A	Spirale Rilsan (5 spire) / Rilsan spiral (5 coils) / Spirale Rilsan (5 Windungen) / Spirale Rilsan (5 spires) / Espiral Rilsan (5 espire)
6	41801902500	Spirale Rilsan (30 m.) / Rilsan spiral (30 m.) / Spirale Rilsan (30 M.) / Spirale Rilsan (30 m.) / Espiral Rilsan (30 m.)
7	41451904300	Scheda madre / Motherboard / Hauptplatine / Carte mère / Tarjeta madre
7	41451904300A	Sensirion / Sensirion / Sensirion / Sensirion / Sensirion
8	41451801600	Cavo flat 20 vie L.600 mm / Flat cable 20 pin L.600 mm / Flat-Kabel 20polig L.600 mm / Cable flat 20 voies L.600 mm / Flat cable 20 vias L.600 mm
9	41451602802	Pannello di emergenza Wireless / Wireless emergency display / Wireless Notfall-Blende / Panneau d'urgence wireless / Panel emergencia wireless
10	41451403200	Cavo USB da pannello L.500 / USB Cable from display L.500 / USB Kabel von Notfalldisplay L.500 / Câble USB de panneau L.500 / Cable USB del panel L.500
11	412007004	Clickson 110°C / Clickson 110°C / Clickson 110°C / Clickson 110°C / Clickson 110°C
12	41451003700	Pressostato / Pressure switch / Druckschalter / Pressostat / Presostato
13	41601301850	Componente rilevamento portata aria / Air flow measure component / Bauteil für Messung der Luftmenge / Composent pour la mesuration de la quantité d'air / Componente por la medida de l'aire

SUITE COMFORT AIR MATIC 14 M1

Gruppo Matic / Matic group / Matic Gruppe / Groupe Matic / Grupo Matic

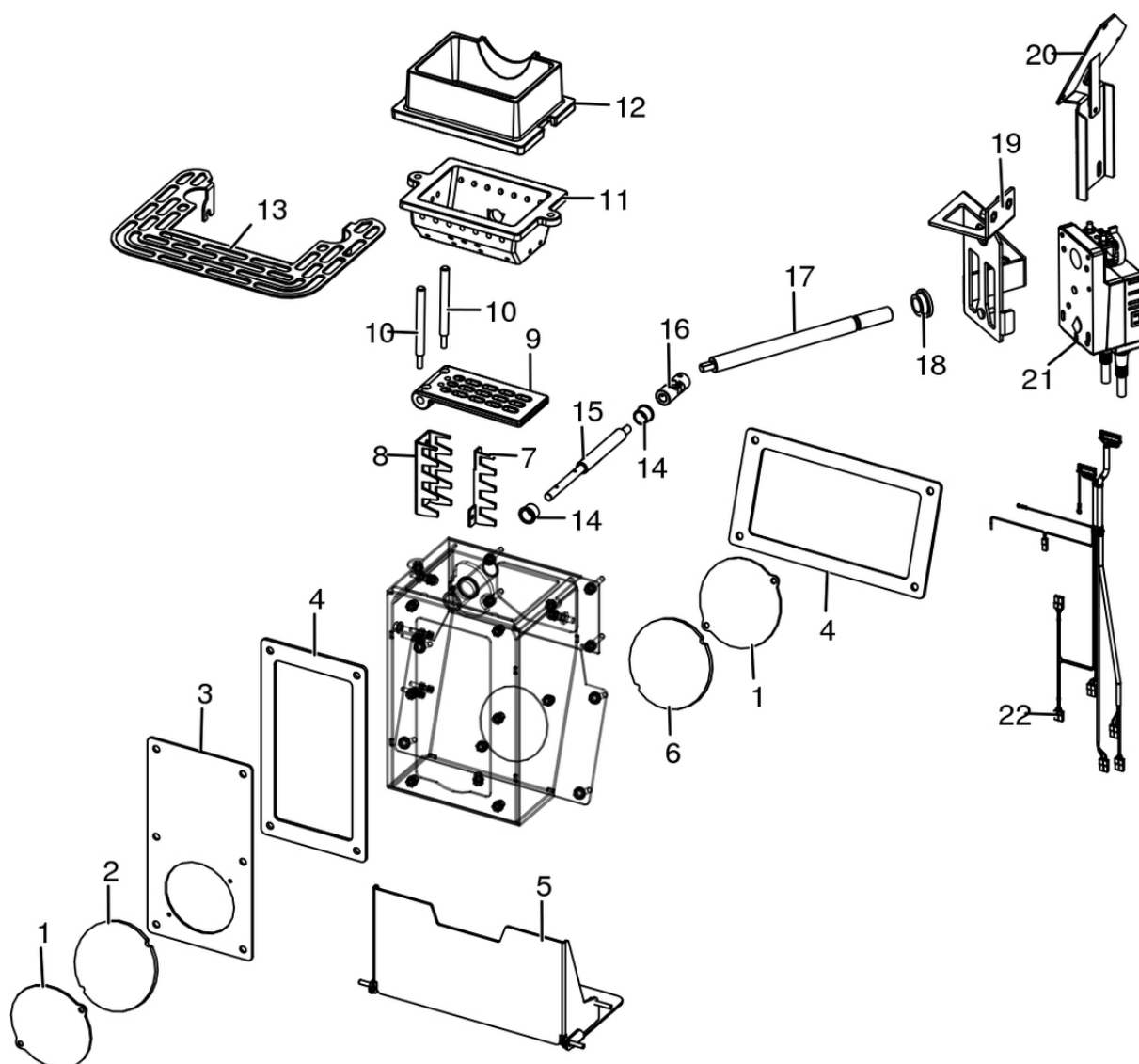

N°	Codice/Code	Descrizioni / Description / Beschreibung / Description / Descripción
1	41401916610	Tappo ispezione / Inspection panel / Inspektionsöffnung / Trappe de visite / Pantalla de inspección
2	41802000100	Guarnizione tasca braciere / Combustion pot container gasket / Brenntopfkasten Dichtung / Joint récipient brasero / Junta contenidor brasero
3	4141194742100	Tappo / Plug / Verchluss / Clapet / Tapón
4	41800900600	Guarnizione / Gasket / Dichtung / Joint / Junta
4	41801599750	Kit 50 guarnizioni / Kit 50 gaskets / Bausatz 50 Dichtungen / Kit 50 joints / Kit 50 juntas
5	41402000430	Frontale cassetto rotativo / Rotating drawer front / Vordere Seit der rotierenden Kasten / Façade tiroir rotatif / Frontal del cajón giratorio
6	41801904500	Guarnizione tasca braciere / Combustion pot container gasket / Brenntopfkasten Dichtung / Joint récipient brasero / Junta contenidor brasero
7	41401902330	Pettine / Comb / Kamm / Peigne / Peine
8	41401916730	Pettine / Scraper / Kratzer / Racleur / Raspador
9	4130180110000	Base braciere / Combustion pot basement / Untergestell Brennschale / Base du brasero / Base brasero
10	41201601400	Perno fondo braciere autopulente (pz.2) / Self-cleaning cast iron bottom grate pin (Pcs.2) / Selbstreinigend Brenntopf aus Gusseisen Bolzen Boden (Stk.2) / Pivot fond brasero en fonte autonettoyant (Pcs.2) / Perno fondo brasero en arrabio autolimpiador (Pz.2)
11	4130180100000	Braciere inferiore / Lower combustion pot / Untere Brennschale / Brasero inférieur / Brasero inferior

12	4130190150000	Braciere superiore / Upper combustion pot / Obere Brennschale / Brasero supérieur / Brasero superior
13	4141194704000	Griglia focolare / Grille / Rost / Grille / Rejilla
14	41201207300	Bronzina / Plain bearing / Lagerhülse / Bague / Cojinete de deslizamiento
15	41201900500	Albero Belimo / Actuator shaft / Trieb Bolzen / Pivot actionneur / Perno actuador
16	41201900250	Giunto / Joint / Gelenk / Joint / Conector
17	41201900400	Asse Belimo / Actuator shaft / Trieb Bolzen / Pivot actionneur / Perno actuador
18	41201216500	Boccola (2 pz) / Bushing (2 pcs) / Buchse (2 Stk) / Douille (2 pcs) / Abrazadera (2 pzs)
19	4141192624000	Piastra nera / Black plate / Schwarze Platte / Plaque noire / Placa negra
20	41401902530	Supporto belimo / Actuator support / Halterung Trieb / Support actionneur / Soporte actuador
21	41451600900	Attuatore rotativo / Actuator / Trieb / Actionneur / Actuador
22	41451905000	Cablaggio / Wiring / Verkabelung / Câblage / Cableado

SUITE COMFORT AIR MATIC 14 M1

Gruppo fumi / Smoke group / Rauchgruppe / Groupe fumées / Grupo de humos

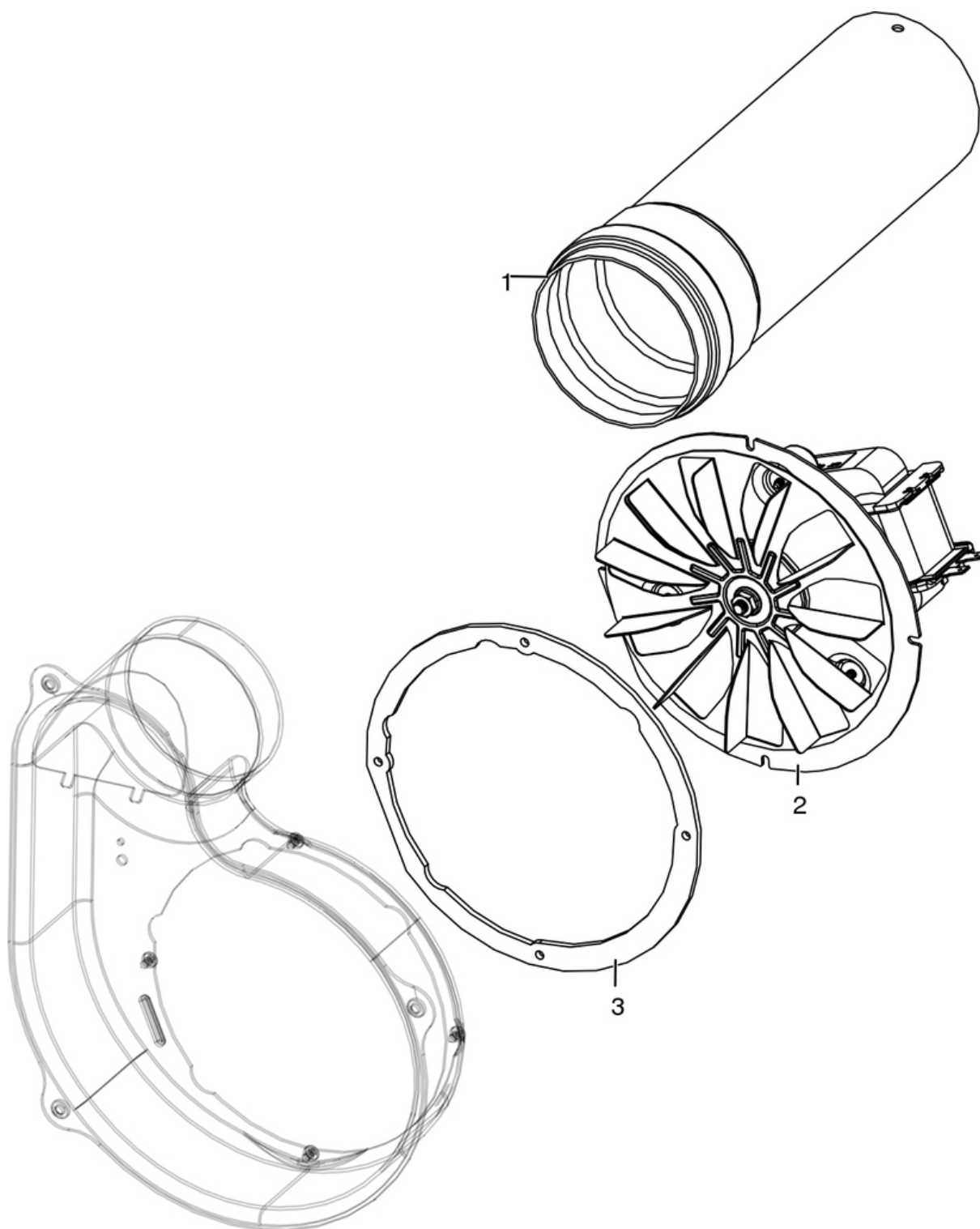

N°	Codice/Code	Descrizioni / Description / Beschreibung / Description / Descripcion
1	41601604560	Tubo fumi Ø 80 con guarnizione / Smoke pipe Ø 80 with gasket / Rauchrohr Ø 80 mit Dichtung / Tuyau fumées Ø 80 avec joint / Tubo humos Ø 80 con junta
2	41451503200	Ventilatore fumi stagno / Air-tight smoke exhausted fan / Luftdichtes Rauchgasgebläse / Ventilateur fumées étanche / Ventilador humos hermético
2	41451209300	Encoder per ventilatore fumi marchi LN2/SIT / Encoder for LN2/SIT smoke fan / Encoder für LN2/SIT

		Rauchgasgebläse / Encoder pour ventilateur des fumées marques LN2/SIT / Encoder para ventilador humos marcas LN2/SIT
2	41451703000	Encoder per ventilatore fumi marchio EBM / Encoder for EMB smoke fan / Encoder für EBM Rauchgasgebläse / Encoder pour ventilateur des fumées marque EBM / Encoder para ventilador humos marca EBM
2	41452009200	Encoder ventilatore / Fan encoder / Lüfter Encoder / Encodeur de ventilateur / Codificador de ventilador
3	41801600800	Guarnizione ventilatore fumi / Smoke exhaust fan gasket / Dichtung Rauchabsauggebläse / Joint Ventilateur aspiration fumées / Junta ventilador aspiración humos

SUITE COMFORT AIR MATIC 14 M1

Gruppo ventilazione / Ventilation group / Lüftungsgruppe / Groupe de ventilation / Grupo de ventilación

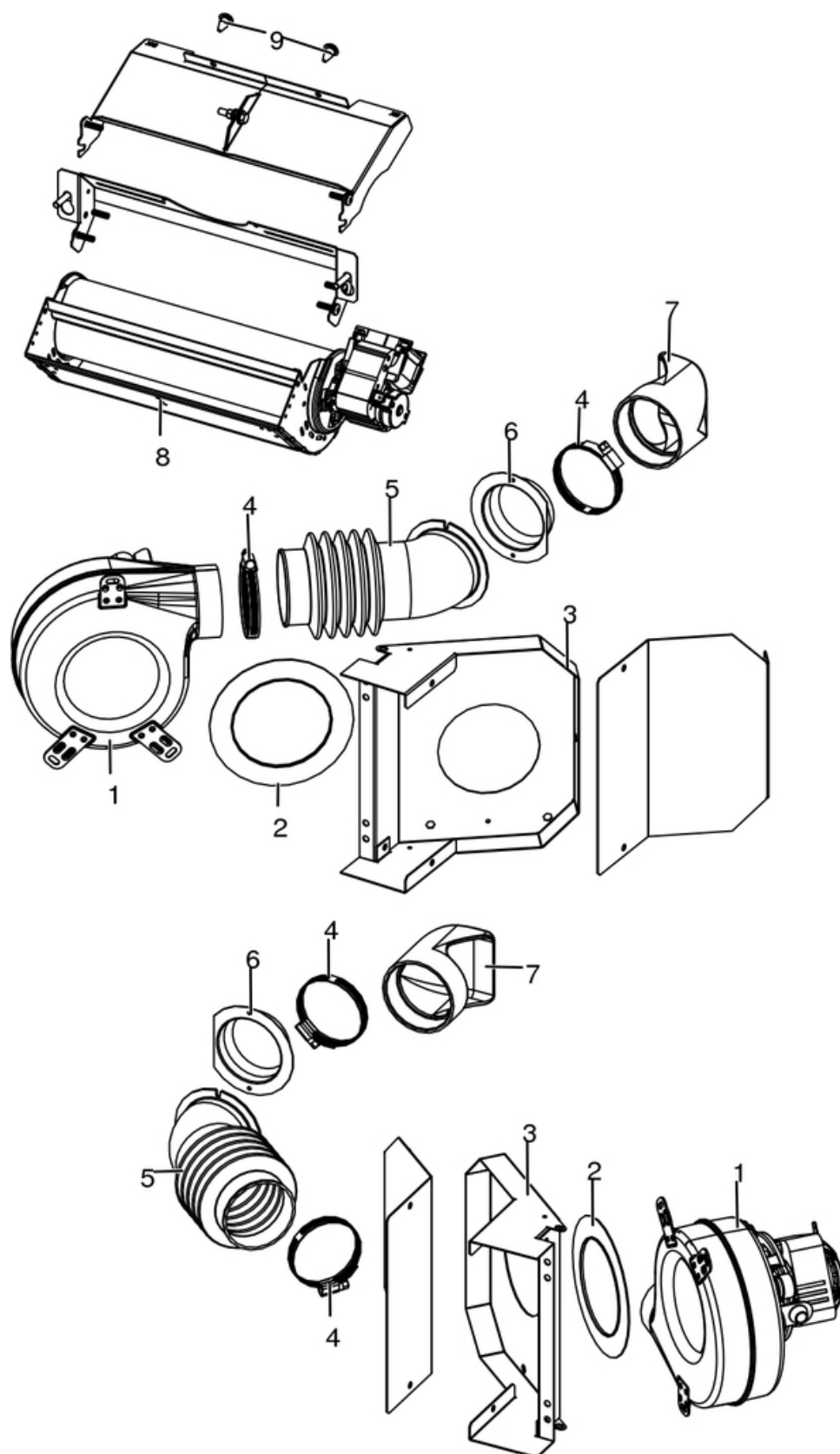

N°	Codice/Code	Descrizioni / Description / Beschreibung / Description / Descripción
1	41451503300	Ventilatore centrifugo / Air fun / Lufgebläse / Ventilateur air / Ventilador aire
2	41801601600	Guarnizione ventilatore / Fan gasket / Dichtung des Gebläses / Joint du ventilateur / Junta ventilador
3	41401624731	Convogliatore C/Air / Conveyor C/Air / Blech C/Air / Convoyeur C/Air / Conductor C/Air
4	41200902000	Fascette Ø 64-76 mm (2 pz) / Clamps Ø 64-76 mm (2 pcs) / Rohrschellen Ø 64-76 mm (2 Stck) / Colliers Ø 64-76 mm (2 pcs) / Bandas Ø 64-76 mm (2 pzs)
5	41801601100	Tubo uscita aria silicone / Outlet air tube in silicone / Luftausgangrohr aus Silikon / Tuyau de sortie air en silicone / Tubo de salida aire en silicona
6	4011011	Flangia Ø 6 / Flange Ø 6 / Flansch Ø 6 / Bride Ø 6 / Brida Ø 6
7	41801605300	Bocchetta posteriore in silicone / Silicone rear air outlet / Luftauslass aus Silikon / Diffuseur air en silicone / Boquilla aire en silicona
8	41451600800	Ventilatore aria / Air fan / Luftgebläse / Ventilateur air / Ventilador aire
9	41801002300	Paracolpi in silicone Ø 8/5 (2pz) / Silicone bumpers Ø 8/5 (2pcs) / Schlagschutzgummi Ø 8/5 (2 Stck) / Pièces silicone antichoc Ø 8/5 (2pcs) / Anti-golpes en silicona Ø 8/5 (2pzs)