

## PHILO COMFORT AIR 14 M1

Gruppo estetico / Aesthetic group / Aesthetische Gruppe / Groupe esthétique / Grupo estético

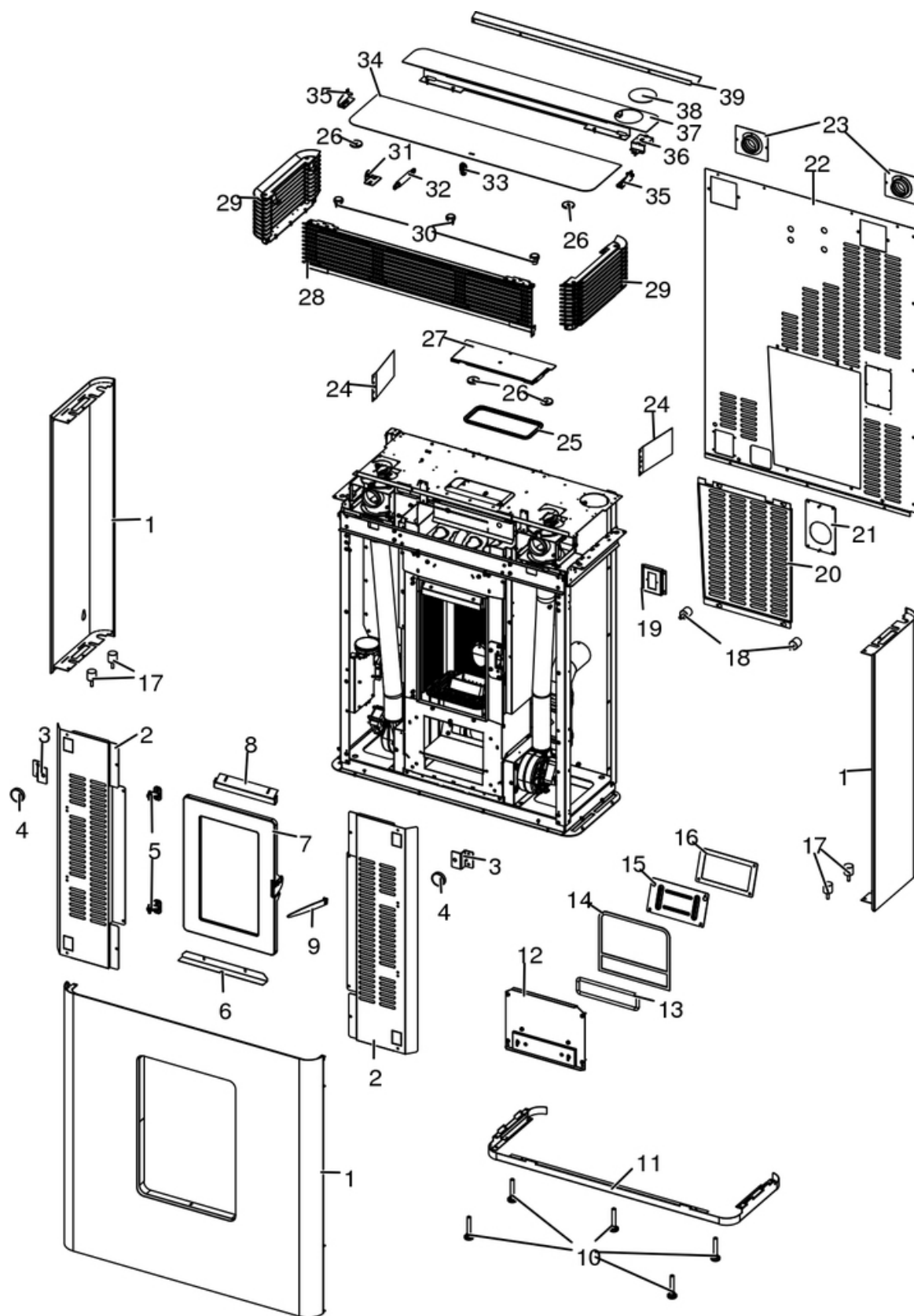

N°	Codice/Code	Descrizioni / Description / Beschreibung / Description / Descripción
1	6918013	Rivestimento Dark Metal / Cladding Dark Metal / Verkleidung Dark Metal / Habillage Dark Metal / Revestimiento Dark Metal
1	6918014	Rivestimento Bronze / Metal cladding Bronze / Metallverkleidung Bronze / Habillage metal Bronze / Revestimiento metal Bronze
1	6918015	Rivestimento completo White metal / Complete White metal cladding / Komplette Verkleidung White metal / Habillage complète White metal / Revestimiento completo White metal
1	6918016	Rivestimento Aluminium / Metal cladding Aluminium / Metallverkleidung Aluminium / Habillage metal Aluminium / Revestimiento metal Aluminium
1	6918017	Rivestimento Bordeaux / Metal cladding Bordeaux / Metallverkleidung Bordeaux / Habillage metal Bordeaux / Revestimiento metal Bordeaux
2	41401837230	Pannello protezione / Protection panel / Schutzpaneel / Panneau de protection / Panel de proteccion
3	41401837130	Staffa fissaggio magnete / Magnet bracket / Magnetbügel / Etrier aimant / Abrazadera iman
4	41801001500	Magnete / Magnet / Magnet / Aimant / Imán
5	41201504460	Cerniera porta (2 pz.) / Door hinge (2 pc.) / Tür Scharnier (2 Stk.) / Charnière porte (2 pc.) / Bisagra puerta (2)
6	4141188703100	Profilo sottoporta / Under door profile / Untertür- Profil / Profil dessous de porte / Perfil debajo puerta
7	437018195	Porta completa / Complete door / Komplette Tür / Porte complète / Puerta completa
8	41411615430V	Deflettore aria / Air deflector / Luftleitblech / Déflecteur aire / Deflector aire
9	41331701860	Gancio "mano fredda" 2017 / "Cool hand" hook MCZ / Haken "Kalte Hand" MCZ / Crochet "main froide" MCZ / Gancho "mano fría" MCZ
10	41200906660	Piedini di appoggio (4 pz.) / Support feet (4 pcs.) / Einstellfüße (4 Stck.) / Vérins d'appui (4 p.es) / Pies de apoyo (4 piezas)
11	4141188233100	Profilo basamento esterno / External base profile / Aussen- Basis- Profil / Profil base externe / Perfil base externa
12	437018290	Tappo cenere / Ash plug / Aschendeckel / Trappe de cendres / Tapon ceniza
13	4120104A	Cordino fibroceramico Ø 12 mm (5 mt.) / Ceramic fibre cord Ø 12 mm (5 m.) / Keramikfaserschnur Ø 12 mm (5 m) / Cordon en fibre céramique Ø 12 mm (5 m) / Junta a cuerda de fibra cerámica Ø 12 mm (5 m)
13	4120104B	Cordino fibroceramico Ø 12 mm (50 mt.) / Ceramic fibre cord Ø 12 mm (50 m.) / Keramikfaserschnur Ø 12 mm (50 m) / Cordon en fibre céramique Ø 12 mm (50 m) / Junta a cuerda de fibra cerámica Ø 10 mm (52 m)
13	41201041	Kit sostituzione cordino (cordino+silicone) Ø 12 mm / Cord replacement kit (cord + silicon) Ø 12 mm / Schnuraustauschsatz (Schnur+Silikon) Ø 12 mm / Kit remplacement cordon (cordon + silicone) Ø 12 mm / Kit sustitución junta a cuerda (junta a cuerda+silicón) Ø 12 mm
14	4120573A	Guarnizione a nastro 8 mm (5 mt.) per porta / Door strip gasket 8 mm (5 m) / Türbanddichtung 8 mm (5 m) / Joint ruban 8 mm (5 m) pour porte / Guarnición de cinta para puerta 8 mm (5 m)
14	4120573B	Guarnizione a nastro 8 mm (50 mt.) per porta / Door strip gasket 8 mm (50 m) / Türbanddichtung 8 mm (50 m) / Joint ruban 8 mm (50 m) pour porte / Guarnición de cinta para puerta 8 mm (50 m)
15	41401339610	Tappo ispezione vano fumi / Smoke compartment inspection plug / Inspektionsdeckel Rauchabzug / Clapet inspection compartiment fumées / Tapón inspección compartimento humos
16	41800900600	Guarnizione / Gasket / Dichtung / Joint / Junta
16	41801599750	Kit 50 guarnizioni / Kit 50 gaskets / Bausatz 50 Dichtungen / Kit 50 joints / Kit 50 juntas
17	41201701950	Gommini antivibrante / Vibration damper rubber / Rammschutz Gummi / Caoutchouc antivibratoire / Cauchitos antivibración
18	41201105600	Antivibranti (10 pz) / anti-vibration mountings (10 pcs) / Schwingungsdämpfer (10 Stck) / Éléments antivibratoires (10 pcs) / Anti-vibraciones (10 pz)
19	41401601830	Supporto interruttore / Switch support / Unterstützung On/Off Taste / Support interrupteur / Apoyo Interruptor
20	41401825631	Coperchio schiena / Back cover / Rückwand Deckel / Couvercle du dossier / Tapadera panel trasero
21	41401823110	Flangia / Flange / Flansch / Bride / Brida
22	41401825131	Schiena / Back / Rückwand / Dossieret / Panel trasero
23	4141188454000	Flangia posteriore / Rear flange / Flansch hinten / Bride postérieure / Brida trasero
24	4180180403000	Rete protezione / Protection grid / Schutznetz / Grillage protection / Red protección
25	41801601400	Guarnizione coperchio serbatoio / Pellet hopper cover gasket / Deckel Pelletbehälter Dichtung / Joint couvercle résevoir pellet / Junta tapa depósito pellet
26	41801657900	Magneti (pz.2) / Magnet (pcs.2) / Magnet (stk. 2) / Aimant (pcs.2) / Imán (pz.2)
27	41421808650	Coperchio tecnico completo / Complete technical cover / Komplette technische Deckel / Couvercle technique complet / Tapa técnica completa
28	41421808850	Griglia anteriore / Front grille / Vordere Gitter / Grille antérieure / Rejilla anterior
29	41421808750	Laterale griglia / Side grille / Seitengrill / Latéral grille / Latéral Rejilla
30	4120180	Gommini paracolpi (4 pz) / Rubber bumpers (4 pcs.) / Schlagschutzgummi (4 Stck) / Pièces caoutchouc antichoc (4 pcs) / Cauchitos anti-golpes (4 pz)

<b>31</b>	<b>4141188583000</b>	Cerniera per pistone / Piston hinge / Kolbenscharnier / Charnière de piston / Bisagra de pistón
<b>32</b>	<b>41801101400</b>	Pistone a gas / Gas-piston / Gas-Kolben / Piston à gaz / Pistón a gas
<b>33</b>	<b>41801602200</b>	Maniglia siliconica / silicone handle / Silikongriff / Poignée de silicone / Tirador de silicona
<b>34</b>	<b>4141188554100</b>	Coperchio pellet / Pellet hopper cover / Deckel Pelletbehälter / Couvercle réservoir pellet / Tapadera depósito pellet
<b>35</b>	<b>4141188593000</b>	Cerniera dx/sx coperchio / RH/LH hinge cover / RS/LS Kolbendeckel / Charnière droite et gauche du couvercle / Bisagra IZDA/DCHA de top
<b>36</b>	<b>4140182573000</b>	Supporto tappo estetico / Aesthetic cover support / Unterstützung des ästhetischen Deckels / Support du couvercle esthétique / Soporte de tapa estética
<b>37</b>	<b>4141188564000</b>	Top posteriore / Rear top / Hintere Abdeckplatte / Dessus posterieur / Top posterior
<b>38</b>	<b>4141176264000</b>	Tappo top / Top cover / Abdeckung / Couvercle dessus / Tapon del top
<b>39</b>	<b>4131180130000</b>	Profilo posteriore / Rear profile / Hinteres Profil / Profil postérieur / Perfil trasero

## PHILO COMFORT AIR 14 M1

Porta fuoco / Fire door / Feuertür / Porte foyer / Puerta hogar

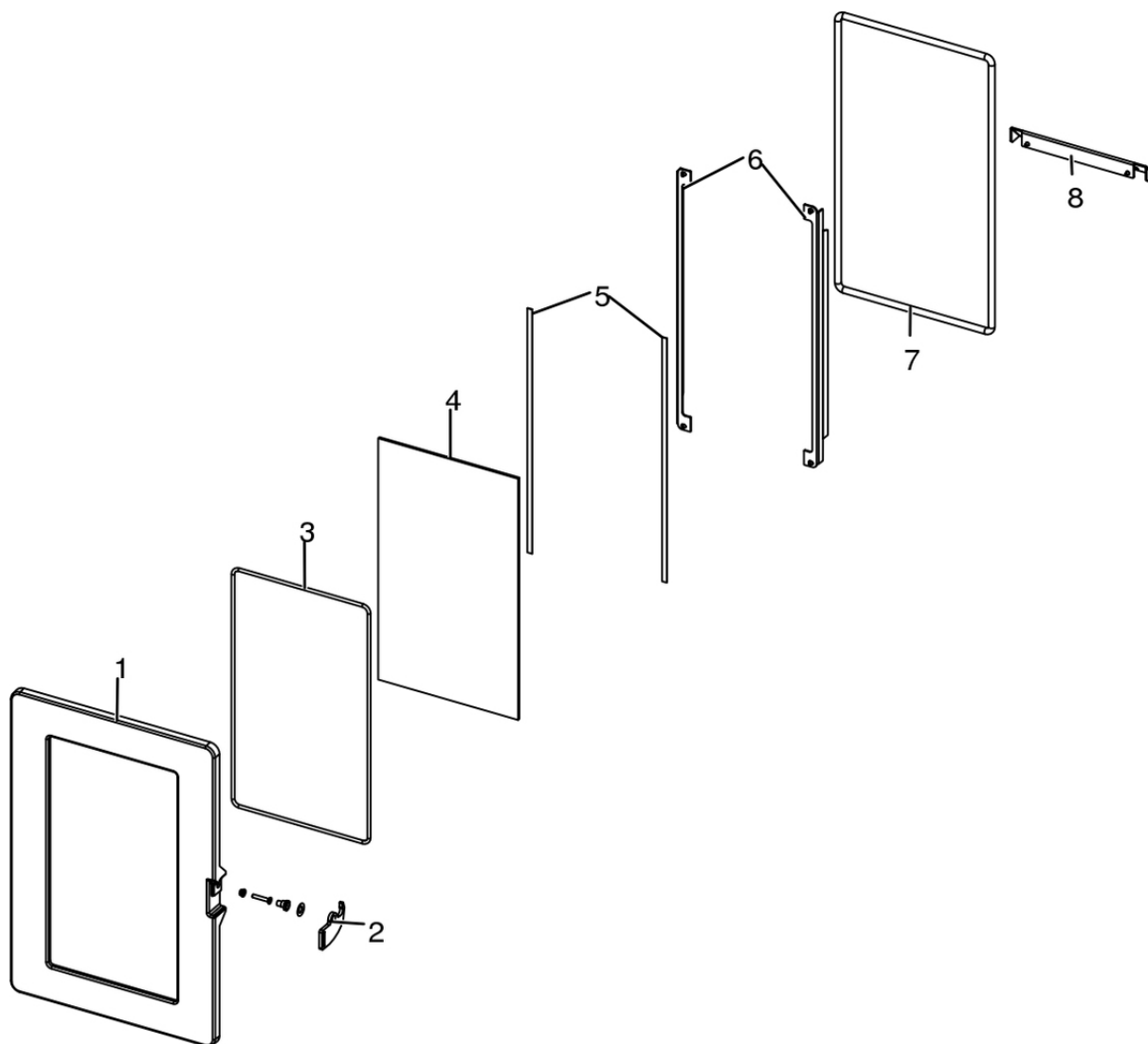

N°	Codice/Code	Descrizioni / Description / Beschreibung / Description / Descripción
1	4130180070000	Telaio porta fuoco in ghisa / Cast iron fire door frame / Feuertürrahment aus Guß / Cadre porte foyer en fonte / Armazón puerta hogar de arrabio
2	41401424160	Maniglia completa / Complete handle / Kompletter Griff / Poignée complète / Tirador completo
3	4120106	Guarnizione a nastro fireglass / Fireglass tape gasket / Banddichtung Fireglass / Joint ruban Fireglass / Guarnición a cinta Fireglass
4	41701600300	Vetroceramico porta ghisa / Cast iron door glass / Glaskeramikscheibe Tür aus Gusseise / Vitrocéremique porte en fonte / Cristal cerámico puerta en arrabio
5	4120573A	Guarnizione a nastro 8 mm (5 mt.) per porta / Door strip gasket 8 mm (5 m) / Türbanddichtung 8 mm (5 m) / Joint ruban 8 mm (5 m) pour porte / Guarnición de cinta para puerta 8 mm (5 m)
5	4120573B	Guarnizione a nastro 8 mm (50 mt.) per porta / Door strip gasket 8 mm (50 m) / Türbanddichtung 8 mm (50 m) / Joint ruban 8 mm (50 m) pour porte / Guarnición de cinta para puerta 8 mm (50 m)
6	41411622030V	Profilo fermavetro / Fastening bracket profile / Haltebügel für Scheibebefestigung Profil / Profil patte de fixation / Perfil fermacrystal
7	4120104A	Cordino fibroceramico Ø 12 mm (5 mt.) / Ceramic fibre cord Ø 12 mm (5 m.) / Keramikfaserschnur Ø 12 mm (5 m) / Cordon en fibre céramique Ø 12 mm (5 m) / Junta a cuerda de fibra cerámica Ø 12 mm (5 m)
7	4120104B	Cordino fibroceramico Ø 12 mm (50 mt.) / Ceramic fibre cord Ø 12 mm (50 m.) / Keramikfaserschnur Ø 12 mm (50 m) / Cordon en fibre céramique Ø 12 mm (50 m) / Junta a cuerda de fibra cerámica Ø 10 mm (52 m)
7	41201041	Kit sostituzione cordino (cordino+silicone) Ø 12 mm / Cord replacement kit (cord + silicon) Ø 12 mm / Schnuraustauschsatz (Schnur+Silikon) Ø 12 mm / Kit remplacement cordon (cordon + silicone) Ø 12 mm / Kit sustitución junta a cuerda (junta a cuerda+silicón) Ø 12 mm

8	41411622130V	Scivolo cenere / Ash ramp / Aschenrutsche / Glissèrie cendre / Tobogán ceniza
---	--------------	---

## PHILO COMFORT AIR 14 M1

Gruppo camera di combustione / Combustion chamber group / Verbrennungskammer Gruppe / Group de chambre de combustion / Grupo cámara de combustión

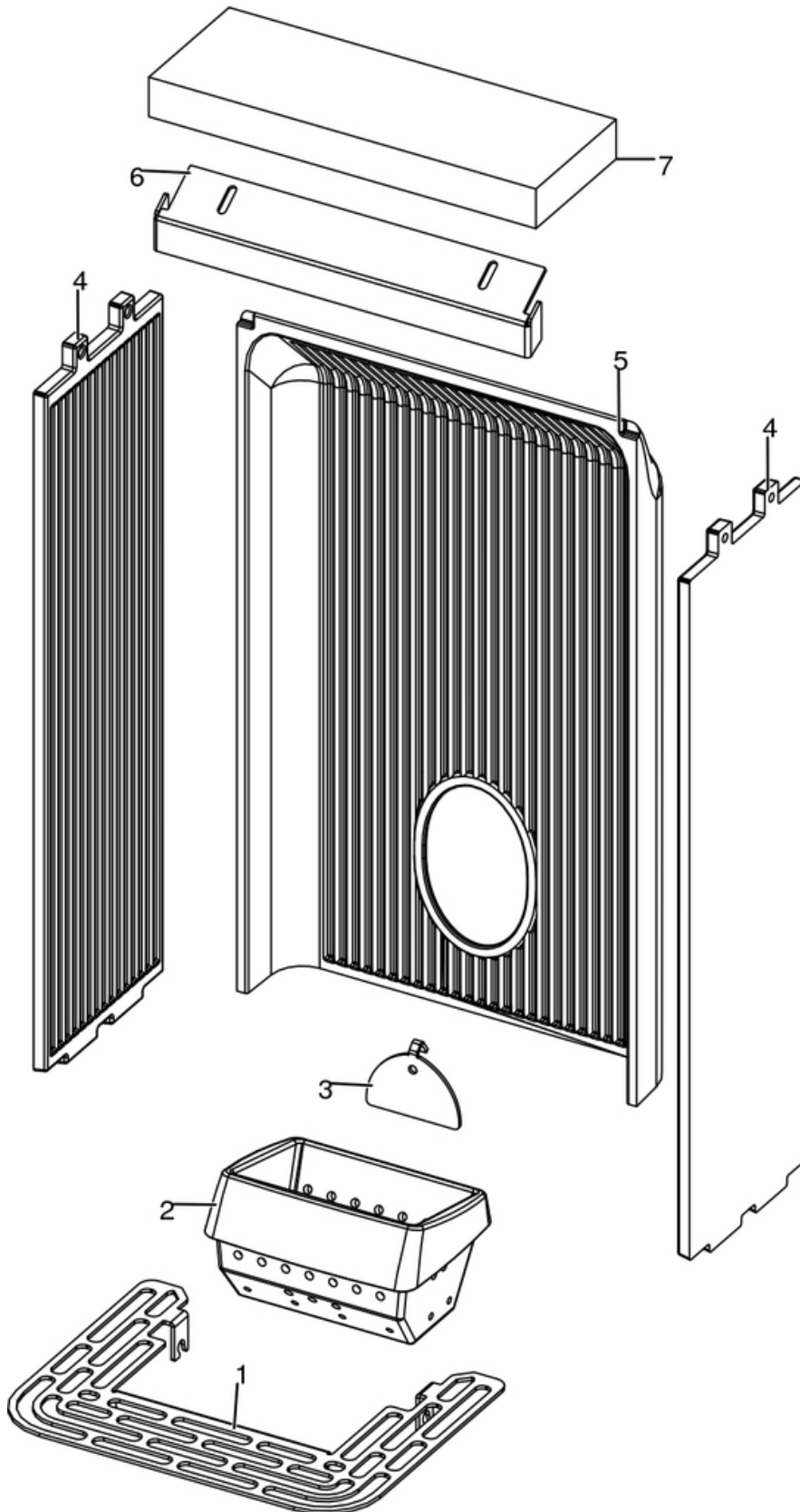

N°	Codice/Code	Descrizioni / Description / Beschreibung / Description / Descripcion
1	41411634830V	Griglia focolare / Fire Box Grille / Feuerstellenrost / Grille Foyer / Rejilla Hogar
2	41301502400V	Braciere ghisa / Cast iron grate / Brennertopf aus Gusseisen / Brasero en fonte / Brasero en arrabio
3	41411613530V	Deflettore pellet / Pellet deflector / Pellet Leitblech / Deflecteur pellet / Deflector pellet
4	41301502500V	Fianco ghisa / Cast iron side / Seite aus Guß / Côté en fonte / Placa lateral de arrabio
5	41301502600V	Schiena ghisa / Cast iron back / Rückwand aus Gusseisen / Dossieret en fonte / Parte trasera en arrabio
6	41411615430V	Deflettore aria / Air deflector / Luftleitblech / Déflecteur aire / Deflector aire
7	41151600200	Deflettore focolare in vermiculite / Vermiculite deflector / Leitblech aus Vermiculite / Déflecteur en vermiculite / Deflector en vermiculite

## PHILO COMFORT AIR 14 M1

Gruppo accensione / Ignition group / Entzündung Gruppe / Groupe d'allumage / Grupo ignición

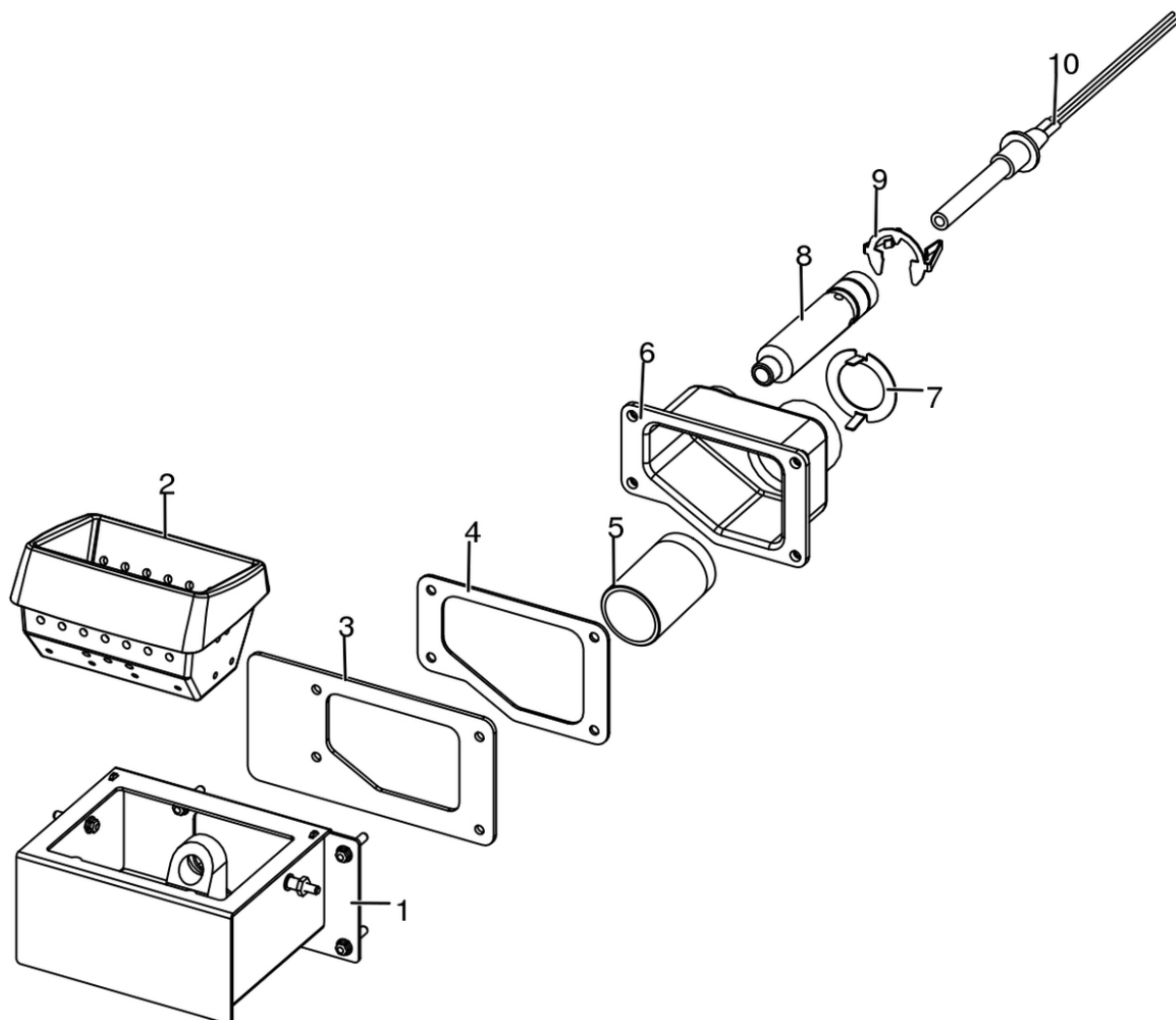

N°	Codice/Code	Descrizioni / Description / Beschreibung / Description / Descripción
1	41411613140V	Tasca braciere / Combustion pot container / Brenntopfkasten / Récipient brasero / Contenidor brasero
2	41301502400V	Braciere ghisa / Cast iron grate / Brennertopf aus Gusseisen / Brasero en fonte / Brasero en arrabio
3	41801601500	Guarnizione tasca braciere / Combustion pot container gasket / Brenntopfkasten Dichtung / Joint récipient brasero / Junta contenidor brasero
4	41801602300	Guarnizione codolo / Gasket / Dichtung / Joint / Junta
5	41501701599	Manicotto potenziamento accensione / Combustion air extension pipe / Zusatzrohr für Nachrüstung / Tuyau amélioration allumage / Tubo impulso de encendido
6	41311803500	Codolo / Tool chuck / Einspannschaft / Outil d'emmanchement / Mango
7	41401629410	Regolatore ingresso aria comburente / Combustion air intake adjuster / Regler Eingang Verbrennungsluft / Régulateur arrivée air comburant / Regulador entrada aire comburente
8	41601601000	Condotto candeledda / Sparkplug Conduit / Zündkerzenkanal / Conduit Bougie / Conducto Bujía
9	41201601500	Anello arresto candeledda / Sparkplug stop / Zündkerzestopper / Butée bougie / Tope bujía
10	41451308101	Candeledda 315 Watt / Sparkplug 315 Watt / Zündkerze 315 Watt / Bougie 315 Watt / Bujía 315 Watt
10	41451308150	Kit 25 candeledda 315 Watt / 25 Sparkplugs 315 Watt kit / Bausatz 25 Zündkerzen 315 Watt / Kit 25 Bougies 315 Watt / Kit 25 Bujías 315 Watt



## PHILO COMFORT AIR 14 M1

Gruppo caricamento pellet / Pellet feed group / Pellet Fördergruppe / Groupe chargement du pellet / Grupo de carga pellet

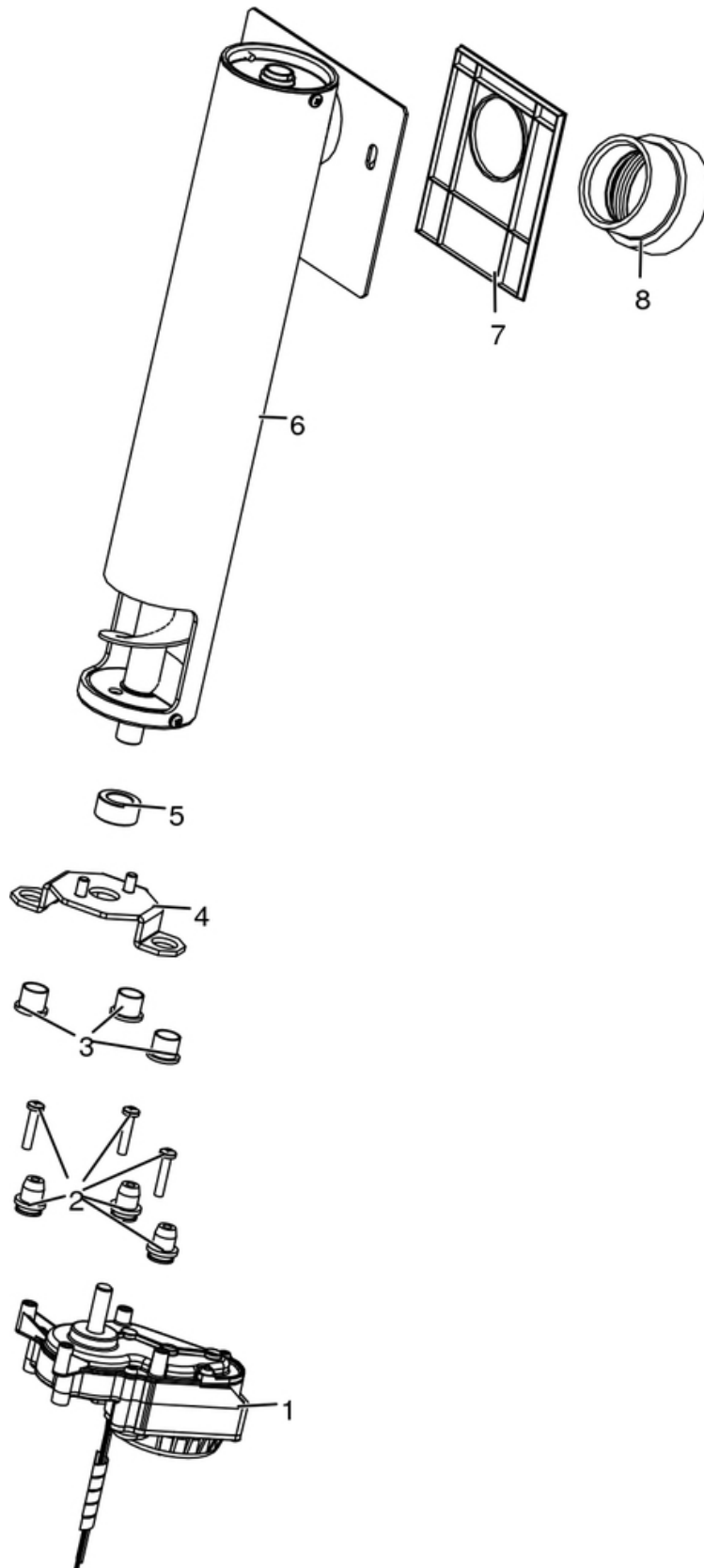

N°	Codice/Code	Descrizioni / Description / Beschreibung / Description / Descripción
1	41451702200	Motoriduttore brushless / Brushless reduction motor / Brushless Getriebemotor / Motoréducteur brushless / Motorreductor brushless
2	41801703700	Gommini antivibrante / Vibration damper rubber / Rammschutz Gummi / Caoutchouc antivibratoire / Cauchitos antivibración
3	41201800700	Boccola (3 pz) / Bushing (3 pcs) / Buchse (3 Stk) / Douille (3 pcs) / Abrazadera (3 pzs)
4	41411779331	Supporto coclea "Ragno" / Pellet feed screw bracket "spider" / "Spinne" Schenke Gestell / Support vis sans fin "Araignée" / Soporte coclea "Araña"
5	4120398	Connettore motoriduttore-coclea / Reduction motor-feed screw connector / Verbindung Getriebemotor-Schnecke / Connecteur motoréducteur-vis sans fin / Conector motorreductor-cóclea
6	41411881150	Assieme coclea / Auger set / Schneckebausatz / Groupe vis sans fin / Grupo vis sin fin
7	41801600400	Guarnizione gruppo caricamento / Gasket / Dichtung / Joint / Junta
8	41801702600	Disaccoppiatore mesc. Marrone / Brown disengaging device / Braun Verängungsrohr / Tuyau de découplage maron / Tubo de desvío marron

## PHILO COMFORT AIR 14 M1

Gruppo aria comburente / Combustion air group / Verbrennungsluft Gruppe / Groupe air comburant / Grupo aire comburente

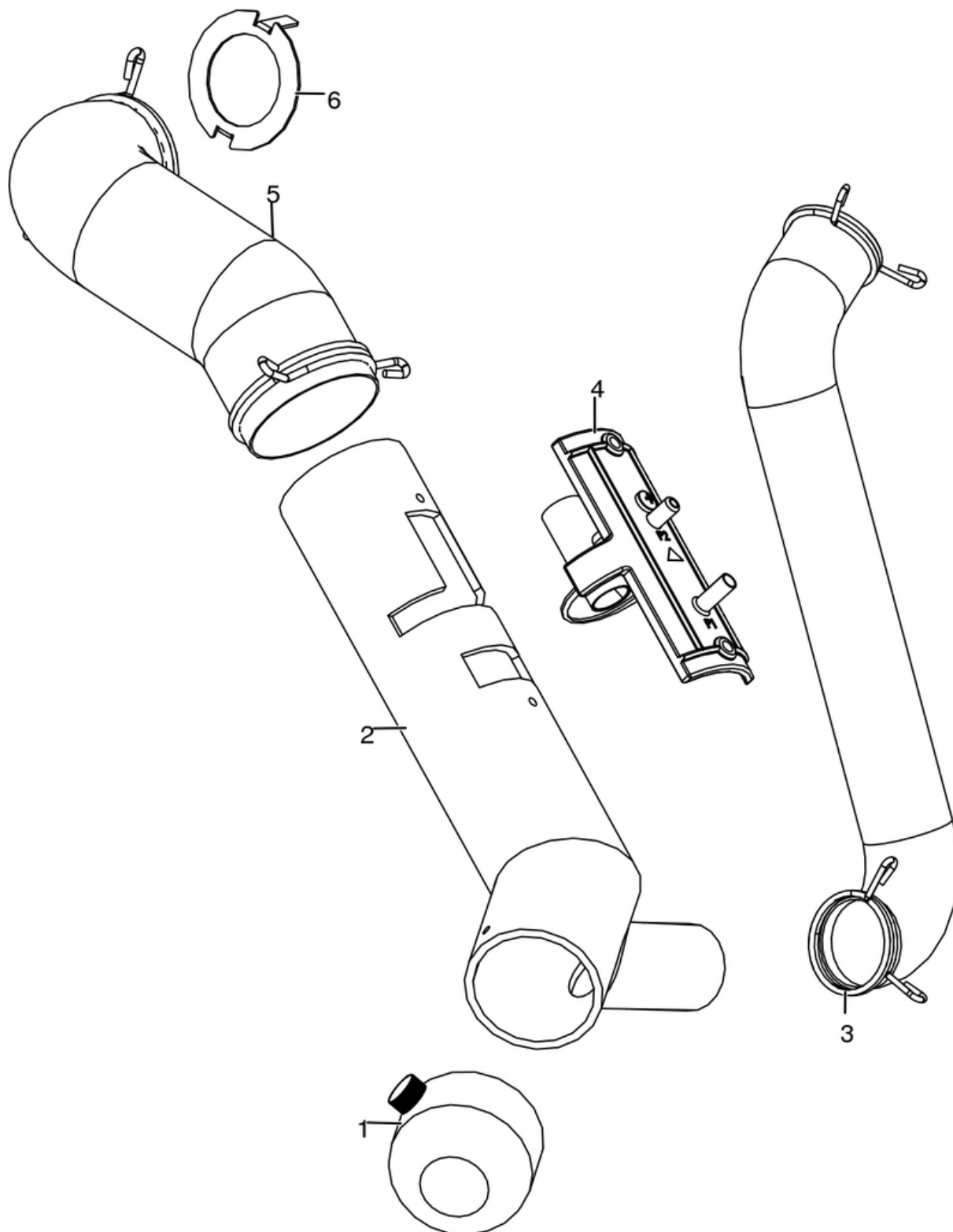

N°	Codice/Code	Descrizioni / Description / Beschreibung / Description / Descripción
1	41401036100	Filtro antipolvere / Anti-dust filter / Staubschutzfilter / Filtre antipoussière / Filtro de protección polvo
2	41601805760	Tubo aspirazione / Aspiration tube / Förderrohr / Tuyau aspiration / Tubo aspiración

<b>3</b>	<b>41801601900</b>	Tubo aspirazione pulizia vetro / Inlet pipe for cleaning glass air / Glassreinigungs Lufteingangrohr / Tuyau entrée pour l'aire de nettoyage du vitre / Tubo entrada por l'aire de limpieza vidrio
<b>4</b>	<b>41601301850</b>	Componente rilevamento portata aria / Air flow measure component / Bauteil für Messung der Luftmenge / Composent pour la mesuration de la quantité d'air / Componente por la medida de l'aire
<b>5</b>	<b>41801601700</b>	Tubo aspirazione camera combustione / Combustion chamber aspiration tube / Verbrennungskammer Förderrohr / Tuyay aspiration air chambre de combustion / Tubo aspiración aire cámara de combustión
<b>6</b>	<b>41401629410</b>	Regolatore ingresso aria comburente / Combustion air intake adjuster / Regler Eingang Verbrennungsluft / Régulateur arrivée air comburant / Regulador entrada aire comburente

## PHILO COMFORT AIR 14 M1

Gruppo elettrico ed elettronico fino al SN 2102260060002 / Electrical and electronic group up to SN 2102260060002 / Elektrische und elektronische Gruppe bis zur SN 2102260060002 / Groupe électrique et électronique jusqu'au NS 2102260060002 / Grupo eléctrico y electrónico hasta NS 2102260060002

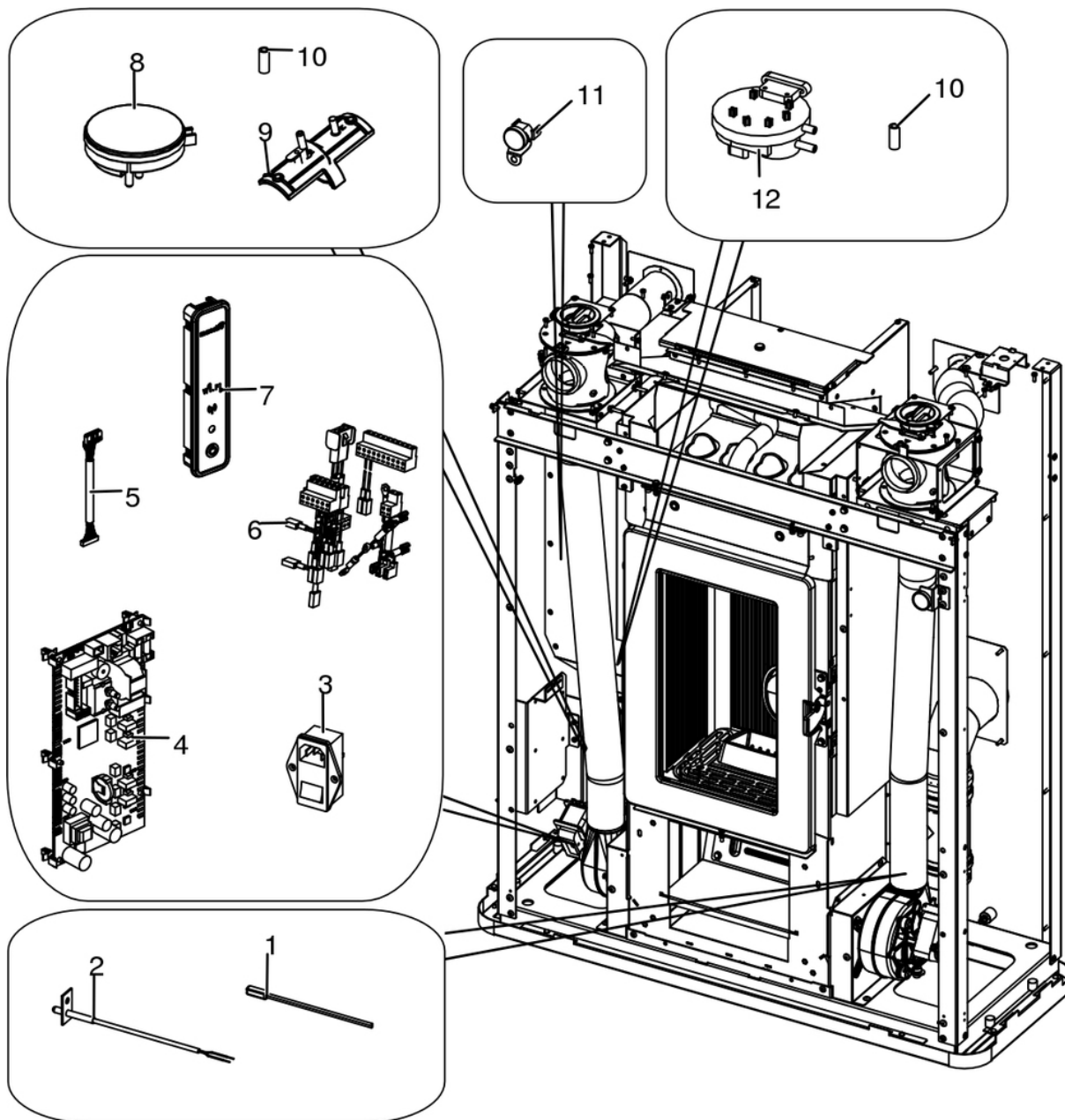

N°	Codice/Code	Descrizioni / Description / Beschreibung / Description / Descripción
1	4160386	Sonda temperatura ambiente/acqua / Room/Water temperature sensor / Raum- Wassertemperaturfühler / Sonde température ambiance/eau / Sonda temperatura ambiente/agua
2	41451703600	Sonda fumi con flangia con morsettiera L.980 / Smoke sensor with flange with terminal board L.980 / Rauchsonde mit Flansche mit Klemmenbrett L.980 / Sonde fumées avec bride avec serre-câble L.980 / Sonda humos con brida con borne L.980
3	4160193	Pulsante accensione / On/Off button / Zündungstaste / Touche d'allumage / Botón encendido
4	41451802200	Scheda elettronica / Electronic board / Elektronische Platine / Carte électronique / Tarjeta electrónica
5	41451801600	Cavo flat 20 vie L.600 mm / Flat cable 20 pin L.600 mm / Flat-Kabel 20polig L.600 mm / Cable flat 20 voies L.600 mm / Flat cable 20 vias L.600 mm
6	41451802600	Cablaggio elettrico / Electrical wiring / Elektrische Verkabelung / Câblage électrique / Cableado eléctrico
6	41451803550	Kit cablaggi messa a terra / Grounding wiring kit / Erdungskabelbaum / Kit mise à terre / Kit cableado a tierra

<b>6</b>	<b>4145200500</b>	Cavo motoriduttore / Reduction motor cable / Kabel Getriebemotor / Câble motoréducteur / Cable motorreductor
<b>7</b>	<b>41451602802</b>	Pannello di emergenza Wireless / Wireless emergency display / Wireless Notfall-Blende / Panneau d'urgence wireless / Panel emergencia wireless
<b>8</b>	<b>41451303400</b>	Trasduttore di pressione / Pressure transducer / Active-Wandler / Transducteur de pression / Transductor de pression
<b>9</b>	<b>41601301850</b>	Componente rilevamento portata aria / Air flow measure component / Bauteil für Messung der Luftmenge / Composent pour la mesuration de la quantité d'air / Componente por la medida de l'aire
<b>10</b>	<b>4120631A</b>	Tubicino siliconico - 5m / Silicon tube - 5m / Silikonrohr - 5m / Petit tuyau en silicone - 5m / Tubo silicónico - 5m
<b>11</b>	<b>412007004</b>	Clickson 110°C / Clickson 110°C / Clickson 110°C / Clickson 110°C / Clickson 110°C
<b>12</b>	<b>41451003700</b>	Pressostato / Pressure switch / Druckschalter / Pressostat / Presostato

## **PHILO COMFORT AIR 14 M1**

**Gruppo elettrico ed elettronico dal SN 2102260060002 / Electrical and electronic group starting from SN 2102260060002 / Elektrische und elektronische Gruppe ab SN 2102260060002 / Groupe électrique et électronique à partir du NS 2102260060002 / Grupo eléctrico y electrónico a partir de NS 2102260060002**

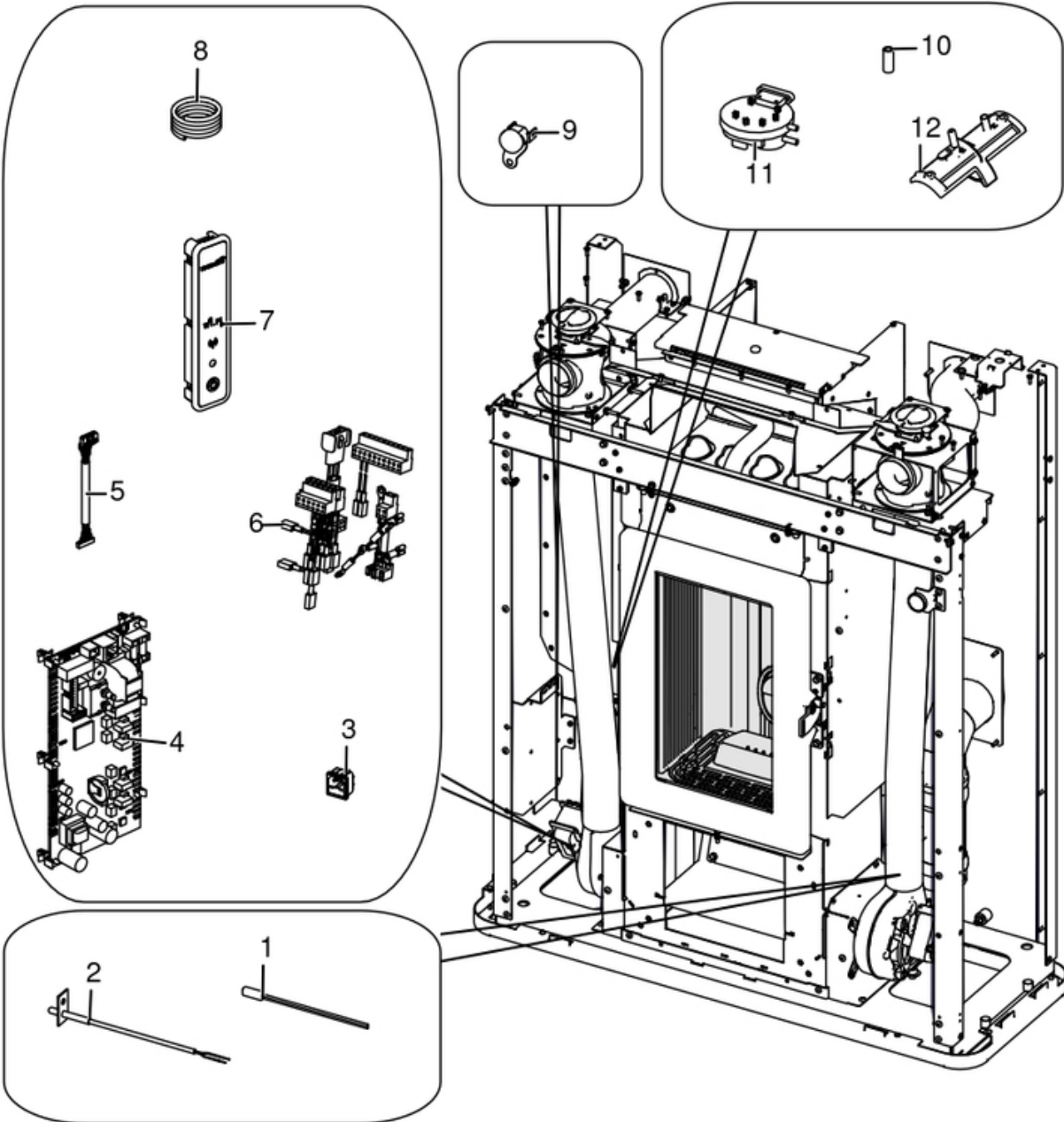



N°	Codice/Code	Descrizioni / Description / Beschreibung / Description / Descripción
1	4160386	Sonda temperatura ambiente/acqua / Room/Water temperature sensor / Raum- Wassertemperaturfühler / Sonde température ambiance/eau / Sonda temperatura ambiente/agua
2	41451703600	Sonda fumi con flangia con morsettiera L.980 / Smoke sensor with flange with terminal board L.980 / Rauchsonde mit Flansche mit Klemmenbrett L.980 / Sonde fumées avec bride avec serre-câble L.980 / Sonda humos con brida con borne L.980
3	41451104100	Presca con fusibile / Socket with fuse / Steckdose mit Sicherung / Prise avec fusible / Toma con fusible
4	41451904300	Scheda madre / Motherboard / Hauptplatine / Carte mère / Tarjeta madre
4	41451904300A	Sensirion / Sensirion / Sensirion / Sensirion / Sensirion
5	41451801600	Cavo flat 20 vie L.600 mm / Flat cable 20 pin L.600 mm / Flat-Kabel 20polig L.600 mm / Cable flat 20 voies L.600 mm / Flat cable 20 vias L.600 mm
6	41451802600	Cablaggio elettrico / Electrical wiring / Elektrische Verkabelung / Câblage électrique / Cableado eléctrico
6	41451900900	Cablaggio elettrico / Electrical wiring / Elektrische Verkabelung / Câblage électrique / Cableado eléctrico
6	41451803550	Kit cablaggi messa a terra / Grounding wiring kit / Erdungskabelbaum / Kit mise à terre / Kit cableado a tierra
6	41452000500	Cavo motoriduttore / Reduction motor cable / Kabel Getriebemotor / Câble motoréducteur / Cable motorreductor
7	41451602802	Pannello di emergenza Wireless / Wireless emergency display / Wireless Notfall-Blende / Panneau d'urgence wireless / Panel emergencia wireless
8	41801902500	Spirale Rilsan (30 m.) / Rilsan spiral (30 m.) / Spirale Rilsan (30 M.) / Spirale Rilsan (30 m.) / Espiral Rilsan (30 m.)
8	41801902500A	Spirale Rilsan (5 spire) / Rilsan spiral (5 coils) / Spirale Rilsan (5 Windungen) / Spirale Rilsan (5 spires) / Espiral Rilsan (5 espire)
9	412007004	Clickson 110°C / Clickson 110°C / Clickson 110°C / Clickson 110°C / Clickson 110°C
10	4120631A	Tubicino siliconico - 5m / Silicon tube - 5m / Silikonrohr - 5m / Petit tuyau en silicone - 5m / Tubo silicónico - 5m
11	41451003700	Pressostato / Pressure switch / Druckschalter / Pressostat / Presostato
12	41601301850	Componente rilevamento portata aria / Air flow measure component / Bauteil für Messung der Luftmenge / Composent pour la mesuration de la quantité d'air / Componente por la medida de l'aire

## PHILO COMFORT AIR 14 M1

Gruppo ventilazione / Ventilation group / Lüftungsgruppe / Groupe de ventilation / Grupo de ventilación

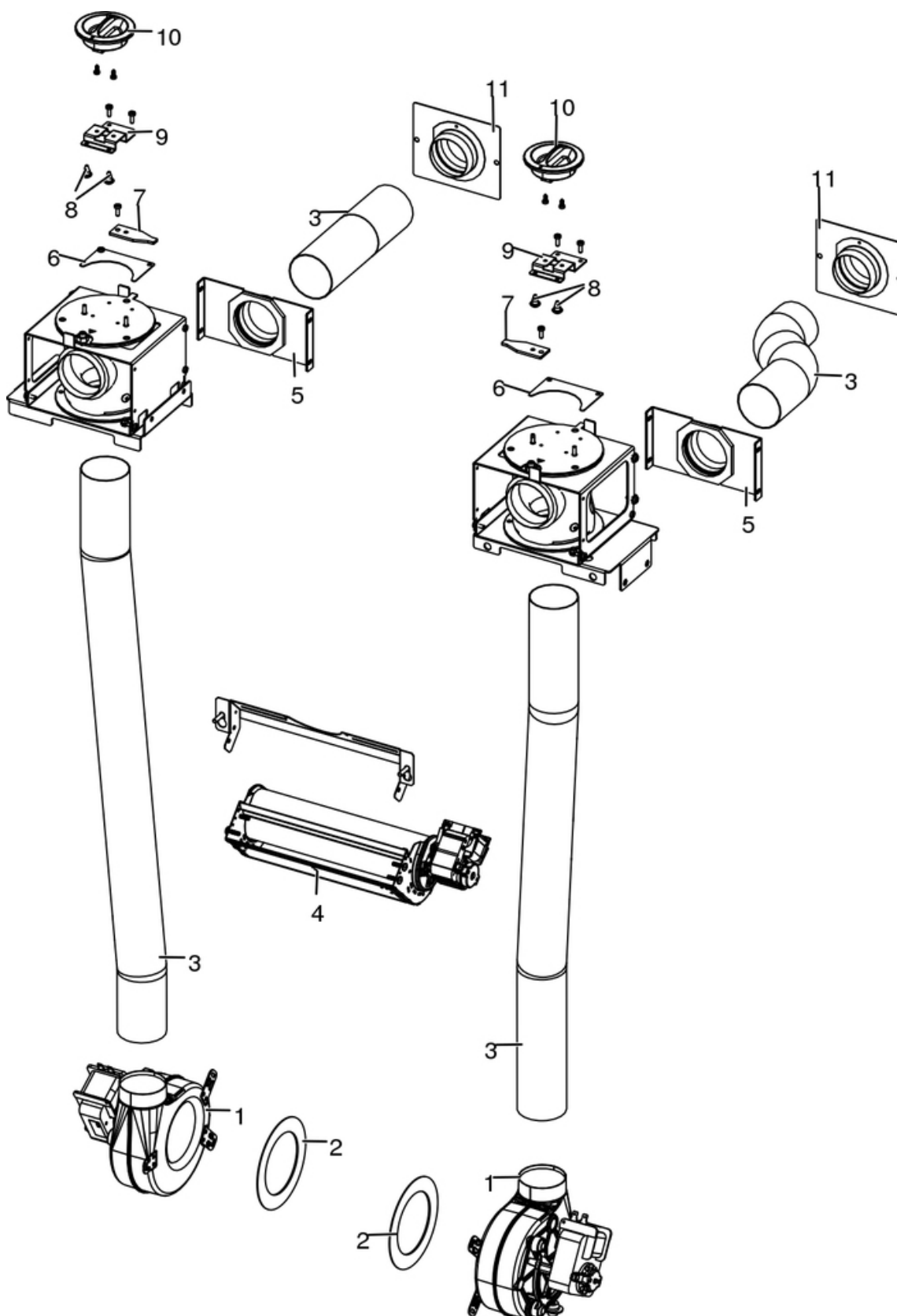

N°	Codice/Code	Descrizioni / Description / Beschreibung / Description / Descripcion
1	41451503300	Ventilatore centrifugo / Air fun / Lufgebläse / Ventilateur air / Ventilador aire
2	41801601600	Guarnizione ventilatore / Fan gasket / Dichtung des Gebläses / Joint du ventilateur / Junta ventilador
3	4009003	Tubo flessibile Ø 60 mm lunghezza 1,5 m / Flex pipe Ø 60 mm length 1,5 m / Schlauch Ø 60 mm Länge 1,5 m / Tuyau flexible Ø 60 mm longueur 1,5 m / Tubo flexible Ø 60 mm lungueza 1,5 m
3	4009017	Tubo flessibile Ø 60 mm lunghezza 8 m / Flex pipe Ø 60 mm length 8 m / Schlauch Ø 60 mm Länge 8 m / Tuyau flexible Ø 60 mm longueur 8 m / Tubo flexible Ø 60 mm lungueza 8 m
4	41451600800	Ventilatore aria / Air fan / Luftgebläse / Ventilateur air / Ventilador aire
5	4141188344000	Tamponazione posteriore / Rear filling / Hintendichtung / Tampon postérieur / Taponado trasero
5	4011011	Flangia Ø 6 / Flange Ø 6 / Flansch Ø 6 / Bride Ø 6 / Brida Ø 6
6	4141188331000	Tamponazione manopola / Handle filling / Griffedichtung / Tampon du poigné / Taponado de mango
7	4141188482000	Fermo removibile / Removable lock / Abnehmbare Verriegelung / Verrouillage amovible / Bloqueo desmontable
8	41801002300	Paracolpi in silicone Ø 8/5 (2pz) / Silicone bumpers Ø 8/5 (2pcs) / Schlagschutzgummi Ø 8/5 (2 Stck) / Pièces silicone antichoc Ø 8/5 (2pcs) / Anti-golpes en silicona Ø 8/5 (2pzs)
9	4141188473000	Supporto manopola / Handle support / Griffhalterung / Support du poigné / Soporte de mango
10	41801101000	Manopola / Knob / Regler / Pommeau / Botón
11	4141188454000	Flangia posteriore / Rear flange / Flansch hinten / Bride postérieure / Brida trasero

## PHILO COMFORT AIR 14 M1

Gruppo fumi / Smoke group / Rauchgruppe / Groupe fumées / Grupo de humos

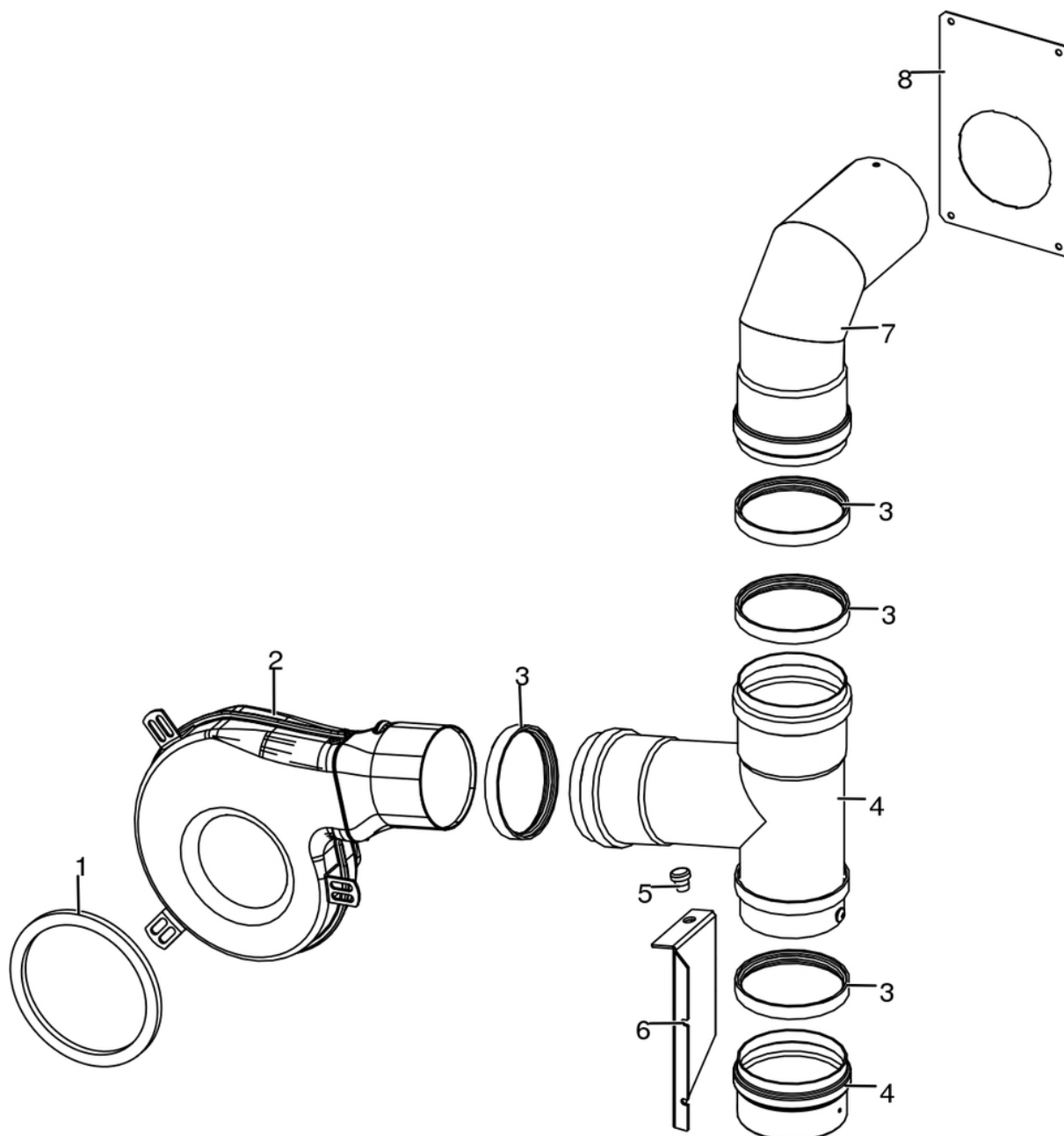

N°	Codice/Code	Descrizioni / Description / Beschreibung / Description / Description
1	41801002600	Guarnizione adesiva voluta fumi / Adhesive gasket smoke volute / Haftendichtung Rauchvolute / Joint adhesive volute fumées / Junta adhesiva voluta humos
1	41801599850	Kit 50 guarnizioni / Kit 50 gaskets / Bausatz 50 Dichtungen / Kit 50 joints / Kit 50 juntas
2	41451801800	Ventilatore fumi / Smoke exhaust fan / Rauchabsauggebläse / Ventilateur aspiration fumées / Ventilador aspiración de humos
3	40120969	Guarnizione silicone (5pz) / Silicone Gasket (5pc.) / Silikondichtung (5 St.) / Joint en silicone / Junta en silicona
4	41601805751	Tubo fumi F/F ad "Y" con guarnizione / "Y" F/F smoke pipe with gasket / "Y" F/F Rauchrohrmit Dichtung / Tuyau fumées "Y" F/F avec joint / Tubo humos "Y" F/F con junta
5	4120180	Gommini paracolpi (4 pz) / Rubber bumpers (4 pcs.) / Schlagschutzgummi (4 Stck) / Pièces caoutchouc antichoc (4 pcs) / Cauchitos anti-golpes (4 pz)
6	41401823630	Staffa di supporto / Support bracket / Haltebügel / Étrier support / Abrazadera de soporte
7	40160467	Curva 90° Ø 8 Nera / Bend 90° Ø 8 Black / Verlauf 90° Ø 8 Schwarz / Coude 90° Ø 8 Noir / Curva 90° Ø 8 Negra

8	41401823110	Flangia / Flange / Flansch / Bride / Brida
---	-------------	--