

TUBE 2013

Componenti Struttura Esterna / External structure components / Bauteile Aussenkorpus / Composants structure externe / Componentes estructura externa

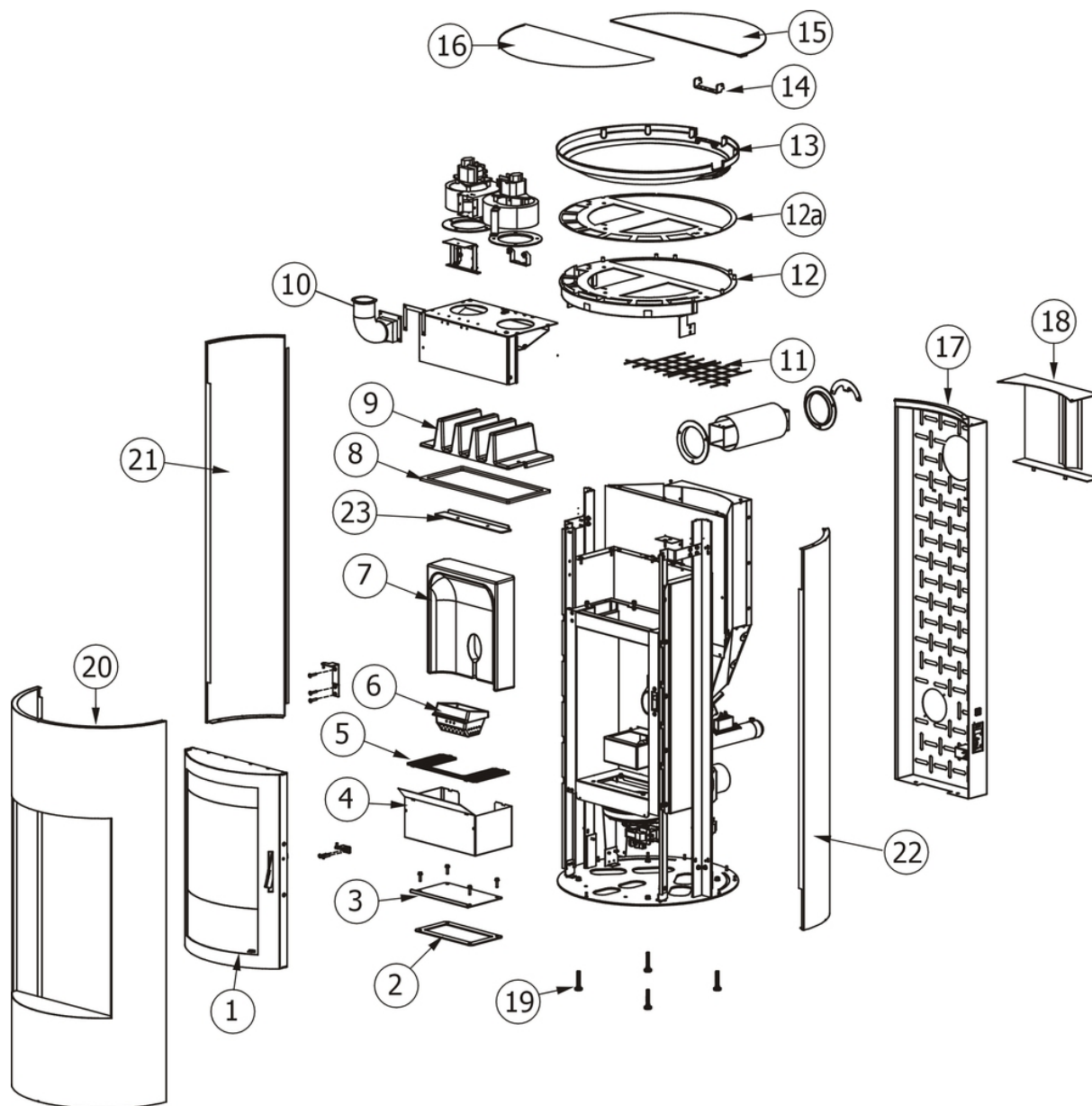

N°	Codice/Code	Descrizioni / Description / Beschreibung / Description / Descripción
1	41401212150	Porta finita completa / Complete finished door / Komplette Tür / Porte finie complète / Puerta completa
2	418008025	Guarnizione / Gasket / Dichtung / Joint / Junta
2	4180080251	Kit 50 guarnizioni / Kit 50 gaskets / Bausatz 50 Dichtungen / Kit 50 joints / Kit 50 juntas
3	41400906330V	Tappo ispezione vano fumi / Smoke compartment inspection plug / Inspektionsdeckel Rauchabzug / Clapet inspection compartiment fumées / Tapón inspección compartimento humos
4	41400958130V	Cassetto cenere / Ash drawer / Aschenkasten / Tiroir à cendres / Cajón ceniza
5	41400906610V	Griglia focolare / Fire box grille / Feuerstellenrost / Grille foyer / Rejilla hogar
6	413008003	Braciere completo in ghisa / Cast iron complete grate / Kompletter Brennertopf aus Gusseisen / Brasero complet en fonte / Brasero completo de arrabio
7	43650151	Schiena in Alutec® / Alutec® back / Rückwand aus Alutec® / Fond en Alutec® / Parte trasera en Alutec®
8	41800802600	Kit 50 guarnizioni / Kit 50 gaskets / Bausatz 50 Dichtungen / Kit 50 joints / Kit 50 juntas
8	41800802601	Guarnizione / Gasket / Dichtung / Joint / Junta

9	413008001	Scambiatore in ghisa / Cast iron exchanger / Gusseiserne Wärmetauscher / Echangeur en fonte / Intercambiador en arrabio
10	41801105100	Curva in silicone nera / Black silicon bend / Schwarze Silikonverlauf / Coude silicone noire / Curva de silicon negra
11	41401230660	Griglia protezione serbatoio / Hopper protection grille / Schutzgitter Pelletbehälter / Grille de protection réservoir / Rejilla de protección depósito
12	41401215141V	Struttura interna top superiore / Internal frame upper top / Interne Struktur oberen Top / Structure interne top superieur / Estructura interna top superior
12a	41401337050	Spessoramento top superiore / Thickening upper top / Vergrößerung der Spalt / Support dessus / Espesor top superior
13	41311101161	Base top in alluminio / Aluminium top base / Untergestell Aluminium Top / Base top aluminium / Base top aluminio
14	41401216631V	Cerniera coperchio serbatoio pellet / Tank cover hinge / Deckelbehälterscharnier / Charnière du couvercle reservoir / Bisagra de la tapa del depósito
15	41411520750	Top anteriore/posteriore nero / Frontal/Rear steel top / Hintere/Vordere Stahlabdeckplatte / Dessus antérieur/postérieur en acier / Top delantero/posterior en acero
16	41411520750	Top anteriore/posteriore nero / Frontal/Rear steel top / Hintere/Vordere Stahlabdeckplatte / Dessus antérieur/postérieur en acier / Top delantero/posterior en acero
17	41401215860	Schiena posteriore nera / Black Back / Hintere schwarze Rückwand / Dossieret postérieur noir / Parte trasera posterior negra
18	41401215560	Diffusore aria posteriore / Rear air diffuser / Hintere Luftdiffusor / Diffuseur air postérieur / Difusor aire trasero
19	412008041	Piedini di appoggio (4 pz.) / Support feet (4 pcs.) / Einstellfüße (4 Stck.) / Vérins d'appui (4 p.es) / Pies de apoyo (4 piezas)
20	41401216761	Pannello frontale nero / Black frontal panel / Vorderes Panel Schwarz / Panneau antérieur noir / Panel frontal negro
20	41401216862	Pannello frontale bronzo / Bronze frontal panel / Vorderes Panel Bronze / Panneau antérieur Bronze / Panel frontal Bronze
20	41401376160	Pannello frontale silver / Silver frontal panel / Vorderes Panel Silber / Panneau antérieur silver / Panel frontal silver
21	41401217861	Pannello laterale sinistro nero / Black left side / Seitliche linke schwarze Platte / Plaque latérale gauche noire / Placa lateral izquierda negra
21	41401217962	Pannello laterale sinistro Bronze / Bronze left side / Seitliche linke Platte Bronze / Plaque latérale gauche Bronze / Placa lateral izquierda Bronze
21	41401376360	Pannello laterale sinistro silver / Silver left side / Seitliche linke silberne Platte / Plaque latérale gauche silver / Placa lateral izquierda silver
22	41401217561	Pannello laterale destro nero / Black right side / Seitliche rechte schwarze Platte / Plaque latérale droite noire / Placa lateral derecha negra
22	41401217662	Pannello laterale destro Bronze / Bronze right side / Seitliche rechte Platte Bronze / Plaque latérale droite Bronze / Placa lateral derecha Bronze
22	41401376260	Pannello laterale destro silver / Silver right side / Seitliche rechte silberne Platte / Plaque latérale droite silver / Placa lateral derecha silver
23	41400939231	Deflettore focolare in acciaio / Steel fire box deflector / Feuerstelleitblech aus Stahl / Déflecteur foyer en acier / Deflector hogar en acero

TUBE 2013

Porta fuoco / Fire door / Feuertür / Porte foyer / Puerta hogar

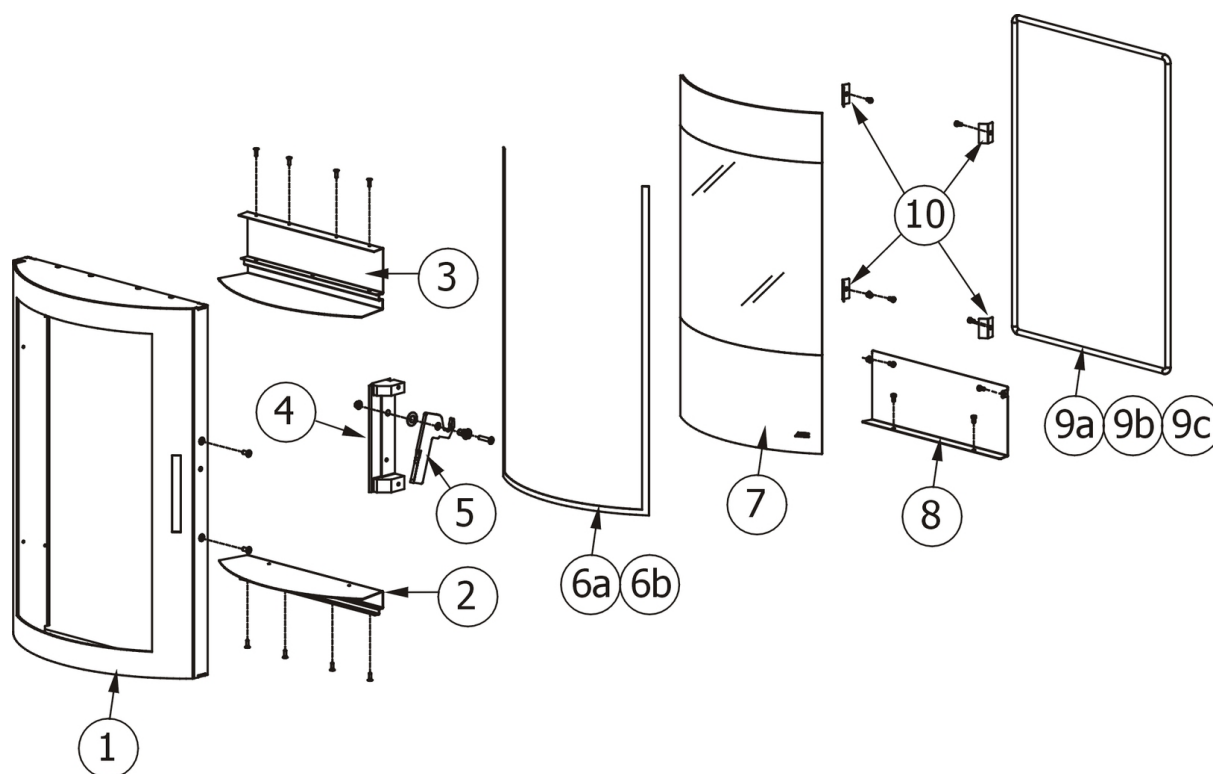

N°	Codice/Code	Descrizioni / Description / Beschreibung / Description / Description
1	41401212240V	Telaio porta nera / Painted black fire door frame / Rahmen Feuertür Schwarz lackiert / Cadre porte foyer laquée noir / Armazón puerta hogar negro barnizado
2	41401213730V	Carter inferiore nero / Lower black casing / Unteres schwarze Gehäuse / Carter inferieur noir / Cárter inferior negro
3	41401213440V	Carter superiore nero / Upper black casing / Oberes schwarze Gehäuse / Carter superieur noir / Cárter superior negro
4	41201200360	Supporto maniglia / Handle bracket / Griff Gestell / Support poignée / Soporte tirador
5	41201200460	Maniglia / Handle / Griff / Poignée / Tirador
6	41201301200A	Guarnizione a nastro 10mm (5 m) / Door strip gasket 10mm (5m) / Türbanddichtung 10mm (5m) / Joint ruban 10mm (5m) / Guarnición cinta puerta 10mm (5m)
7	41701102660	Vetroceramico con guarnizione / Glass with gasket / Glaskeramikscheibe mit Dichtung / Vitrocéramique avec joint / Cristal cerámico con guarnición
8	41401213930V	Salva cenere nero / Black ash savior / Schwarze Ashen Retter / Sauve cendre noir / Salva ceniza negro
9a	4120104A	Cordino fibroceramico Ø 12 mm (5 mt.) / Ceramic fibre cord Ø 12 mm (5 m.) / Keramikfaserschnur Ø 12 mm (5 m) / Cordon en fibre céramique Ø 12 mm (5 m) / Junta a cuerda de fibra cerámica Ø 12 mm (5 m)
9b	4120104B	Cordino fibroceramico Ø 12 mm (50 mt.) / Ceramic fibre cord Ø 12 mm (50 m.) / Keramikfaserschnur Ø 12 mm (50 m) / Cordon en fibre céramique Ø 12 mm (50 m) / Junta a cuerda de fibra cerámica Ø 10 mm (52 m)
9c	41201041	Kit sostituzione cordino (cordino+silicone) Ø 12 mm / Cord replacement kit (cord + silicon) Ø 12 mm / Schnuraustauschsatz (Schnur+Silikon) Ø 12 mm / Kit remplacement cordon (cordon + silicone) Ø 12 mm / Kit sustitución junta a cuerda (junta a cuerda+silicón) Ø 12 mm
10	41401213830	Molla fermavetro porta / Glass fastening brackets spring / Feder Scheibebefestigungsbügel / Ressort étrier de fixation vitre / Muelle abrazaderas fijación cristal

TUBE 2013

Componenti interni meccanici ed elettronici / Electronic and mechanic internal parts / Interne mechanische und elektronische Bauteile / Composants internes mécaniques et électroniques / Componentes internos electrónicos y mecánicos

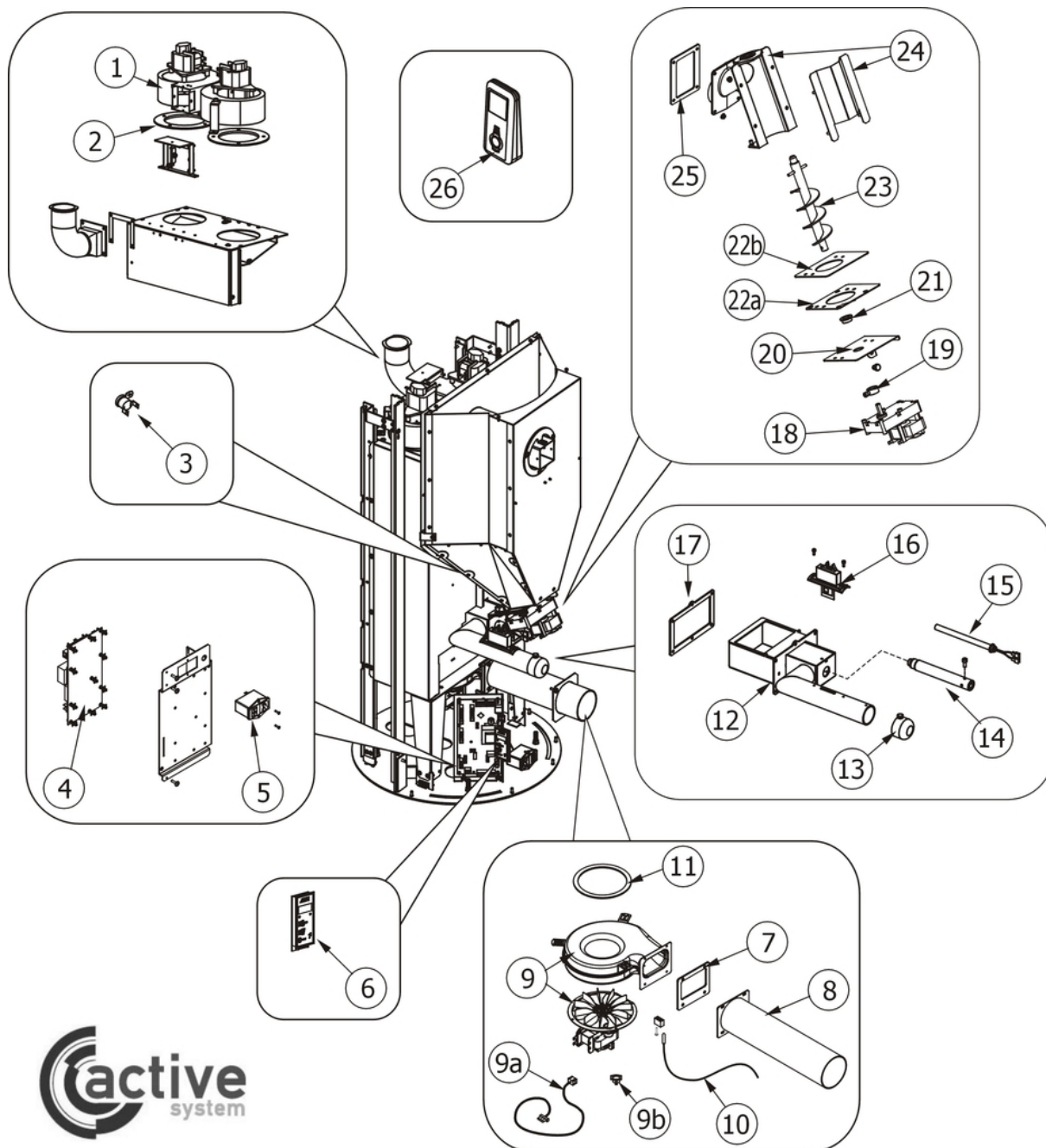

N°	Codice/Code	Descrizioni / Description / Beschreibung / Description / Descripción
1	41451002903	Motore ventilatore portata 170 m3/h / Fan motor capacity 170 m3/h / Gebläsemotor Leistung 170 m3/h / Moteur ventilateur débit 170 m3/h / Motor ventilador caudal 170 m3/h
2	418008018	Guarnizione ventilatore / Fan gasket / Dichtung des Gebläses / Joint du ventilateur / Junta ventilador
3	412007004	Clickson 110°C / Clickson 110°C / Clickson 110°C / Clickson 110°C / Clickson 110°C
4	41450907601	Scheda madre / Motherboard / Hauptplatine / Carte mère / Tarjeta madre
4	41801499750	Kit 868 / Kit 868 / Kit 868 / Kit 868 / Kit 868
5	4160459	Pulsante accensione / On/Off button / Zündungstaste / Touche d'allumage / Botón encendido
6	41450900700	Pannello di emergenza / Emergency panel / Notfalldisplay / Tableau de secours / Panel d'emergencia

6	41801499750	Kit 868 / Kit 868 / Kit 868 / Kit 868 / Kit 868
7	418008030	Guarnizione / Gasket / Dichtung / Joint / Junta
8	416008010	Tubo uscita fumi / Smoke outlet pipe / Rohr Rauchabzug / Tuyau sortie fumées / Tubo salida humos
9	41451003202	Ventilatore aspirazione fumi / Smoke exhausted fan / Rauchabsauggebläse / Ventilateur aspiration fumées / Ventilador aspiración humos
9	41801102500	Guarnizione / Gasket / Dichtung / Joint / Junta
9a	4160477	Cavo ENCODER / ENCODER cable / Drehzahlmesserkabel / Câble ENCODER / Cable ENCODER
9b	41451209300	Encoder per ventilatore fumi marchi LN2/SIT / Encoder for LN2/SIT smoke fan / Encoder für LN2/SIT Rauchgasgebläse / Encoder pour ventilateur des fumées marques LN2/SIT / Encoder para ventilador humos marcas LN2/SIT
10	41450901800	Sonda fumi Active System / Smoke sensor Active System / Rauchgasfühler ACTIVE SYSTEM / Sonde fumées ACTIVE SYSTEM / Sonda humos Active System
11	41801002600	Guarnizione adesiva voluta fumi / Adhesive gasket smoke volute / Haftenddichtung Rauchvolute / Joint adhesive volute fumées / Junta adhesiva voluta humos
11	41801599850	Kit 50 guarnizioni / Kit 50 gaskets / Bausatz 50 Dichtungen / Kit 50 joints / Kit 50 juntas
12	41401069141V	Tasca braciere / Combustion pot container / Brenntopfkasten / Récipient braséro / Contenedor brasero
13	41401036100	Filtro antipolvere / Anti-dust filter / Staubschutzfilter / Filtre antipoussière / Filtro de protección polvo
14	41200903900	Condotto candeletta / Sparkplug conduit / Zündkerzenkanal / Conduit bougie / Conducto bujía
15	41450905000	Candeletta accensione pellet / Pellet ignition sparkplug / Zündkerze Pelletzündung / Bougie d'allumage pellet / Bujía encendido pellet
15	41801599550	Kit 50 candelette / 50 Sparkplugs kit / Bausatz 50 Zündkerzen / Kit 50 Bougies / Kit 50 Bujías
16	41451205000	Sensore aria completo / Complete air sensor / Kompletter Luftfühler / Capteur air complet / Sensor aire completo
17	418008027	Guarnizione / Gasket / Dichtung / Joint / Junta
18	4160278	Motoriduttore 1,5 RPM / Reduction motor 1,5 RPM / Getriebemotor 1,5 RPM / Motorréducteur 1,5 TPM / Motorreductor 1,5 RPM
19	4120398	Connettore motoriduttore-coclea / Reduction motor-feed screw connector / Verbindung Getriebemotor-Schnecke / Connecteur motorréducteur-vis sans fin / Conector motorreductor-cóclea
20	41400944351	Base della coclea / Feed screw base / Untergestell der Förderschnecke / Base de la vis sans fin / Base de la cóclea
21	4120614	Boccola grafitata (2 pz) / Etched bush (2 pcs) / Graphitbuchse (2 Stck) / Bride graphitée (2 pcs) / Brida grafitada (2 pz)
22a	4120615	Guarnizione base della coclea / Feed screw base gasket / Dichtung Untergestell der Förderschnecke / Joint pour la base de la vis sans fin / Junta base de la cóclea
22b	41400903310	Flangia condotto coclea / Base of feed screw conduit / Untergestell Rohrleitung der Förderschnecke / Base du conduit de la vis sans fin / Base de conducto de la cóclea
23	41200901040	Coclea di caricamento pellet / Pellet feed screw / Pelletsförderschnecke / Vis sans fin pour chargement du pellet / Cóclea de carga pellet
24	41401077540V	Condotto della coclea / Conduit of feed screw / Rohrleitung der Förderschnecke / Conduit de la vis sans fin / Conducto de la cóclea
25	418008029	Guarnizione / Gasket / Dichtung / Joint / Junta
26	41451301203	Telecomando nero 434,5MHZ - Funzione impostabile da 0 a 3 Ventilatori / Black remote control 434,5MHZ - From 0 to 3 fan function / Schwarze Fernbedienung 434,5MHZ - Von 0 bis 3-Gebläse-Steuerung / Télécommande noire 434,5MHZ - Fonctionne à partir de 0 à 3 Ventilateurs / Mando a distancia negro 434,5MHZ - Función de 0 a 3 ventiladores
26	41801499750	Kit 868 / Kit 868 / Kit 868 / Kit 868 / Kit 868