

## LINEA COMFORT AIR 9 UP! M1

Gruppo estetico / Aesthetic group / Aesthetische Gruppe / Groupe esthétique / Grupo estético

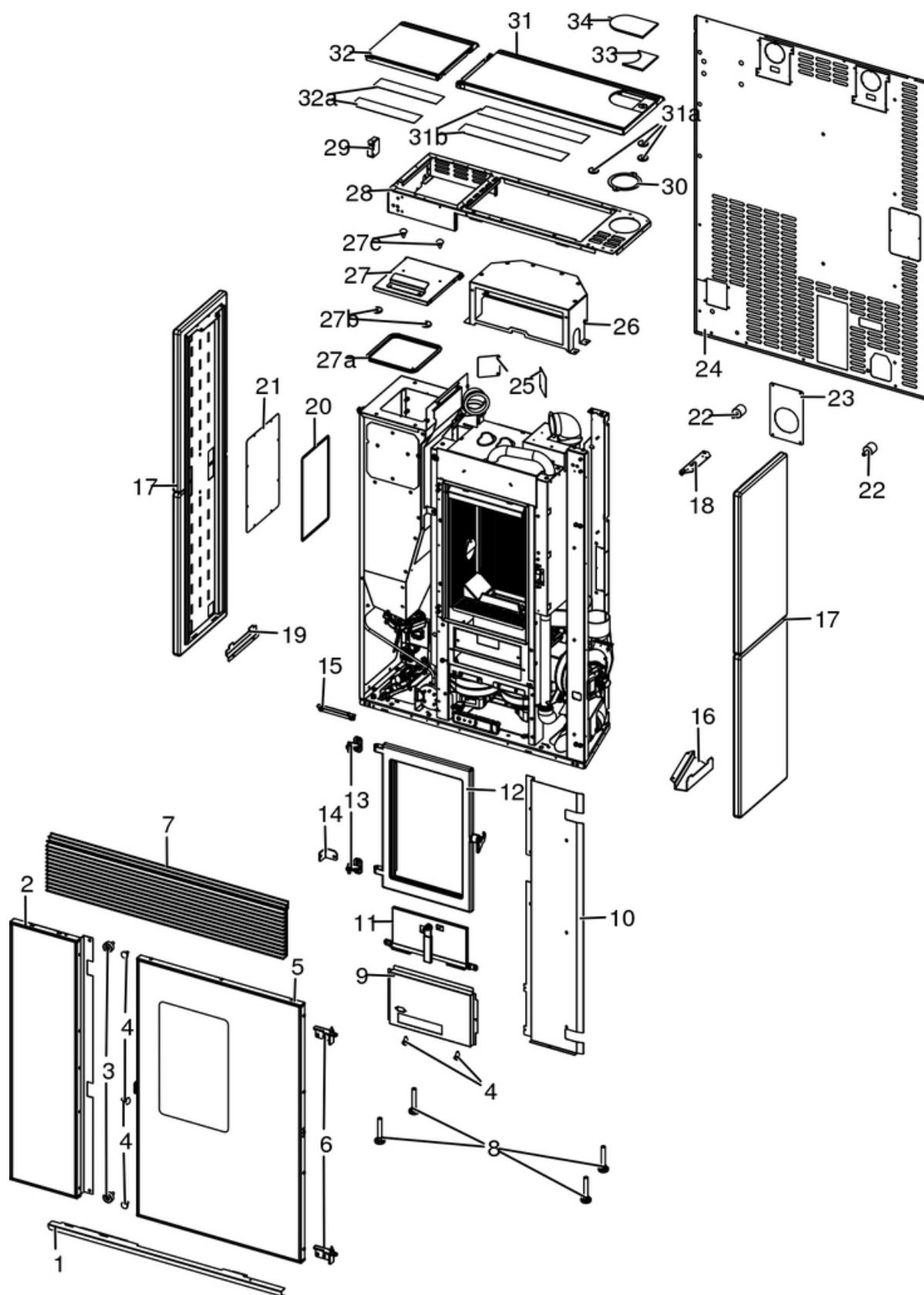

N°	Codice/Code	Descrizioni / Description / Beschreibung / Description / Descripcion
1	41411743430P	Profilo inferiore nero / Black lower profile / Unteres schwarze Profil / Profil inférieur noir / Perfil inferior negro
2	41411744650	Frontale sinistro completo / Complete left front panel / Komplettes linke vordere Paneel / Panneau frontal gauche complet / Panel frontal IZDO completo
3	41201705560	Boccola / Bushing / Buchse / Douille / Abrazadera
4	41801002300	Paracolpi in silicone Ø 8/5 (2pz) / Silicone bumpers Ø 8/5 (2pcs) / Schlagschutzgummi Ø 8/5 (2 Stck) / Pièces silicone antichoc Ø 8/5 (2pcs) / Anti-golpes en silicona Ø 8/5 (2pzs)
5	41411743550	Porta completa esterna / Complete external door / Komplette Außentür / Porte externe complète / Puerta externa completa
6	41411744540V	Cerniera porta esterna / External door hinge / Außentür Scharnier / Charnière porte extérieur / Bisagra puerta exterior
7	41311600220P	Griglia anteriore nera alluminio / Front black aluminum grille / Vordere Aluminium schwarze Gitter / Grille antérieur aluminium noire / Rejilla anterior aluminio negra
8	41200906660	Piedini di appoggio (4 pz.) / Support feet (4 pcs.) / Einstellfüße (4 Stck.) / Vérins d'appui (4 p.es) / Pies de apoyo (4 piezas)
9	4141174334000	Tamponazione centrale inferiore / Lower central filling / Untere zentrale Abdichtung / Tampon centrale inférieur / Taponado centrale inferior
10	4141174323000	Tamponazione DX / R. filling / Abdichtung R. / Tampon D. / Taponado DCHO
11	437018248	Porta cenere / Ash door / Aschentür / Porte de cendres / Puerta ceniza
12	437017119	Porta focolare / Fireplace door / Feuerstelle Tür / Porte foyer / Puerta hogar
13	41201504460	Cerniera porta (2 pz.) / Door hinge (2 pc.) / Tür Scharnier (2 Stk.) / Charnière porte (2 pc.) / Bisagra puerta (2)
14	41411742730V	Blocco porta focolare / Stop for Fireplace door / Stopper für Feuerstelle Tür / Stop pour porte foyer / Tope por puerta hogar
15	41401715131	Supporto frontale sinistro / Frontal left support / Halterung linke Front / Support frontal gauche / Soporte frontal izquierdo
16	41401714330	Staffa inferiore destra ceramica / Right inferior bracket for ceramic / Rechte untere Haltebügel Keramik / Étrier inférieur droite céramique / Abrazadera derecha inferior cerámica
17	41251700250	Ceramiche laterali Black / Black side ceramics / Seitliche Keramik Black / Carreaux latéraux en céramique Black / Cerámicas laterales Black
17	41251700350	Ceramiche laterali Bordeaux / Bordeaux side ceramics / Seitliche Keramik Bordeaux / Carreaux latéraux en céramique Bordeaux / Cerámicas laterales Bordeaux
17	41251700450	Ceramiche laterali White / White side ceramics / Seitliche Keramik White / Carreaux latéraux en céramique White / Cerámicas laterales White
17	41251700950	Laterale Serpentino / Lateral Serpentine / Seite aus Serpentino / Latérale Serpentine / Lateral Serpentino
18	41401907130	Staffa fissaggio fianchi / Sides fixing bracket / Haltebügel für Seite / Étrier fixation cotés / Abrazadera fijacion flanco
19	41401714430	Supporto fianco sinistro / Left side support / Halterung linke Seite / Support coté gauche / Soporte fianco izquierdo
20	4120572A	Guarnizione a nastro 6 mm (5 mt.) per porta / Door strip gasket 6 mm (5 m) / Türbanddichtung 6 mm (5 m) / Joint ruban 6 mm (5 m) pour porte / Guarnición de cinta para puerta 6 mm (5 m)
20	4120572B	Guarnizione a nastro 6 mm (50 mt.) per porta / Door strip gasket 6 mm (50 m) / Türbanddichtung 6 mm (50 m) / Joint ruban 6 mm (50 m) pour porte / Guarnición de cinta para puerta 6 mm (50 m)
21	41401713410	Tappo posteriore serbatoio / Rear hopper cover / Hintere Deckel Behälter / Couvercle postérieur réservoir / Tapa posterior depósito
22	41201105600	Antivibranti (10 pz) / anti-vibration mountings (10 pcs) / Schwingungsdämpfer (10 Stck) / Éléments antivibratoires (10 pcs) / Anti-vibraciones (10 pz)
23	41401823110	Flangia / Flange / Flansch / Bride / Brida
24	41401715232	Schienna / Rear back / Rückwand / Dos / Espalda
25	4140171401000	Tappo convogliatore / Air duct cover / Förderveschluss / Bouchon convoyeur / Tapa conductor
26	41411742850	Convogliatore / Air duct / Förder / Convoyeur / Conductor
27	41401714650	Coperchio tecnico / Technical cover / Technischer Deckel / Couvercle technique / Tapadera técnica
27a	41801604700	Guarnizione tenuta serbatoio / Pellet hopper gasket / Pelletbehälter Dichtung / Joint réservoir pellet / Junta depósito pellet
27b	41801657900	Magneti (pz.2) / Magnet (pcs.2) / Magnet (stk. 2) / Aimant (pcs.2) / Imán (pz.2)
27c	41801002300	Paracolpi in silicone Ø 8/5 (2pz) / Silicone bumpers Ø 8/5 (2pcs) / Schlagschutzgummi Ø 8/5 (2 Stck) / Pièces silicone antichoc Ø 8/5 (2pcs) / Anti-golpes en silicona Ø 8/5 (2pzs)
28	4141184473000	Supporto top / Top support / Deckelhaltebügel / Support du dessus / Soporte del top
29	41201305100	Chiusura a spinta / Push-pull pressure closing / Druckschließung / Fermeture par pression / Cierre a presión
30	4141183651000	Flangia / Flange / Flansch / Bride / Brida

<b>31</b>	<b>41401841750</b>	Top vetro completo / Complete glass top / Komplette Glasdeckel / Dessus en verre complet / Top de cristal completo
<b>31a</b>	<b>41801657900</b>	Magneti (pz.2) / Magnet (pcs.2) / Magnet (stk. 2) / Aimant (pcs.2) / Imán (pz.2)
<b>31b</b>	<b>4120691</b>	Nastro biadesivo H 50 (50 m.) / Double-sided tape H. 50 (50 m.) / Doppelseitiges Klebeband H. 50 (50 m.) / Ruban adhésif double face H. 50 (50 m.) / Cinta de dos lados H. 50 (50 m.)
<b>32</b>	<b>41401841150</b>	Coperchio pellet / Pellet hopper cover / Deckel Pelletbehälter / Couvercle réservoir pellet / Tapadera depósito pellet
<b>32a</b>	<b>4120691</b>	Nastro biadesivo H 50 (50 m.) / Double-sided tape H. 50 (50 m.) / Doppelseitiges Klebeband H. 50 (50 m.) / Ruban adhésif double face H. 50 (50 m.) / Cinta de dos lados H. 50 (50 m.)
<b>33</b>	<b>41411746150</b>	Tappo top completo forato / Complete drilled top cover / Komplette gebohrte Abdeckung / Couvercle percé complet dessus / Tapon perforado completo del top
<b>34</b>	<b>41411746050</b>	Tappo top completo cieco / Complete blind top cover / Komplette blinde Abdeckung / Couvercle aveugle complet dessus / Tapon ciego completo del top

## LINEA COMFORT AIR 9 UP! M1

Gruppo frontale / Frontal group / Frontgruppe / Groupe frontale / Grupo frontal

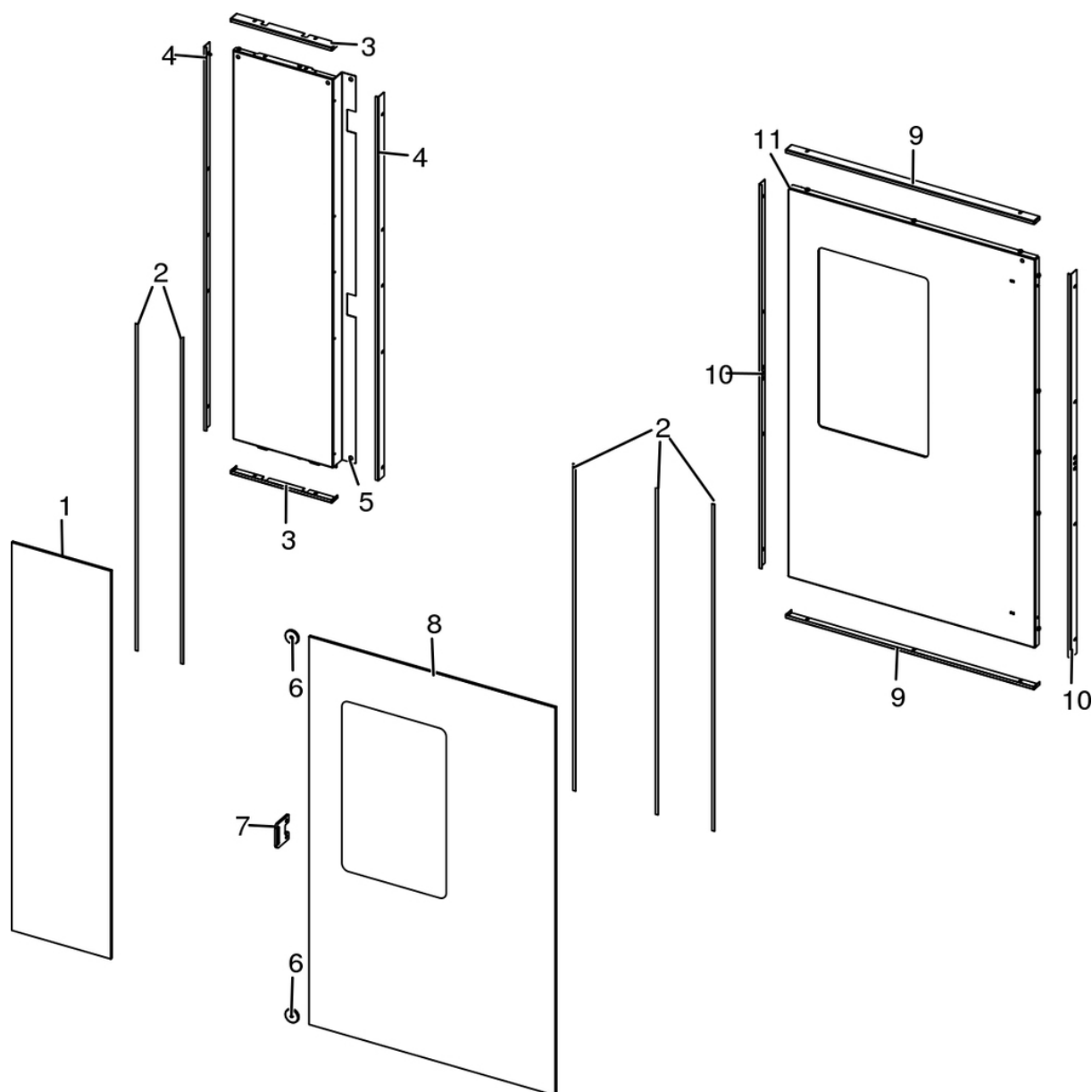

N°	Codice/Code	Descrizioni / Description / Beschreibung / Description / Descripcion
1	41701701260	Vetroceramico frontale sinistro con serigrafia / Front left glass / Vordere linke Glaskeramikscheibe / Vitroc�ramique frontal gauche / Cristal cer�mico frontal izquierdo
2	4120572A	Guarnizione a nastro 6 mm (5 mt.) per porta / Door strip gasket 6 mm (5 m) / T�rbanddichtung 6 mm ( 5 m) / Joint ruban 6 mm (5 m) pour porte / Guarnici�n de cinta para puerta 6 mm (5 m)
2	4120572B	Guarnizione a nastro 6 mm (50 mt.) per porta / Door strip gasket 6 mm (50 m) / T�rbanddichtung 6 mm (50 m) / Joint ruban 6 mm (50 m) pour porte / Guarnici�n de cinta para puerta 6 mm (50 m)
3	41411744830P	Fermavetro sup./inf. telaio frontale / Sup./inf. glass fastening bracket - frontal frame / Ob./Unt. Halteb�gel f�r Scheibebefestigung - vordere Rahmen / Etrier de fixation sup./inf. vitroc�ramique - cadre frontal / Retendor sup./inf. del cristal - Armaz�n frontal
4	41411744930P	Fermavetro laterale frontale / Lateral front glass fastening bracket / Vordere Seitenhalteb�gel f�r Scheibebefestigung / Etrier de fixation lateral frontal vitroc�ramique / Retendor lateral frontal del cristal
5	4141174474000	Telaio frontale sinistro / Left front frame / Linke vorderer Rahmen / Cadre frontal gauche / Armaz�n frontal IZDO
6	41801657900	Magneti (pz.2) / Magnet (pcs.2) / Magnet (stk. 2) / Aimant (pcs.2) / Im�n (pz.2)
7	41411744460	Maniglia porta esterna / External door handle / Au�ent�r Griff / Poign�e porte ext�rieur / Tirador puerta exterior
8	41701701160	Vetroceramico con serigrafia / Glass / Glaskeramikscheibe / Vitroc�ramique / Cristal cer�mico

9	41411744330P	Fermavetro superiore/inferiore porta esterna / Upper/lower glass fastening bracket - External door / Obere/Untere Haltebügel für Scheibebefestigung - Außentür / Etrier de fixation supérieur/inférieur vitrocéramique - porte extérieure / Retendor superior/inferior del cristal - Puerta exterior
10	41411744230P	Fermavetro laterale porta esterna / Lateral glass fastening bracket - External door / Seitenhaltebügel für Scheibebefestigung - Außentür / Etrier de fixation lateral vitrocéramique - porte extérieure / Retendor lateral del cristal - Puerta exterior
11	41411743640V	Telaio porta esterna / External door frame / Außentür Rahmen / Cadre porte externe / Armazón puerta externa

## LINEA COMFORT AIR 9 UP! M1

Gruppo camera di combustione / Combustion chamber group / Verbrennungskammer Gruppe / Group de chambre de combustion / Grupo cámara de combustión

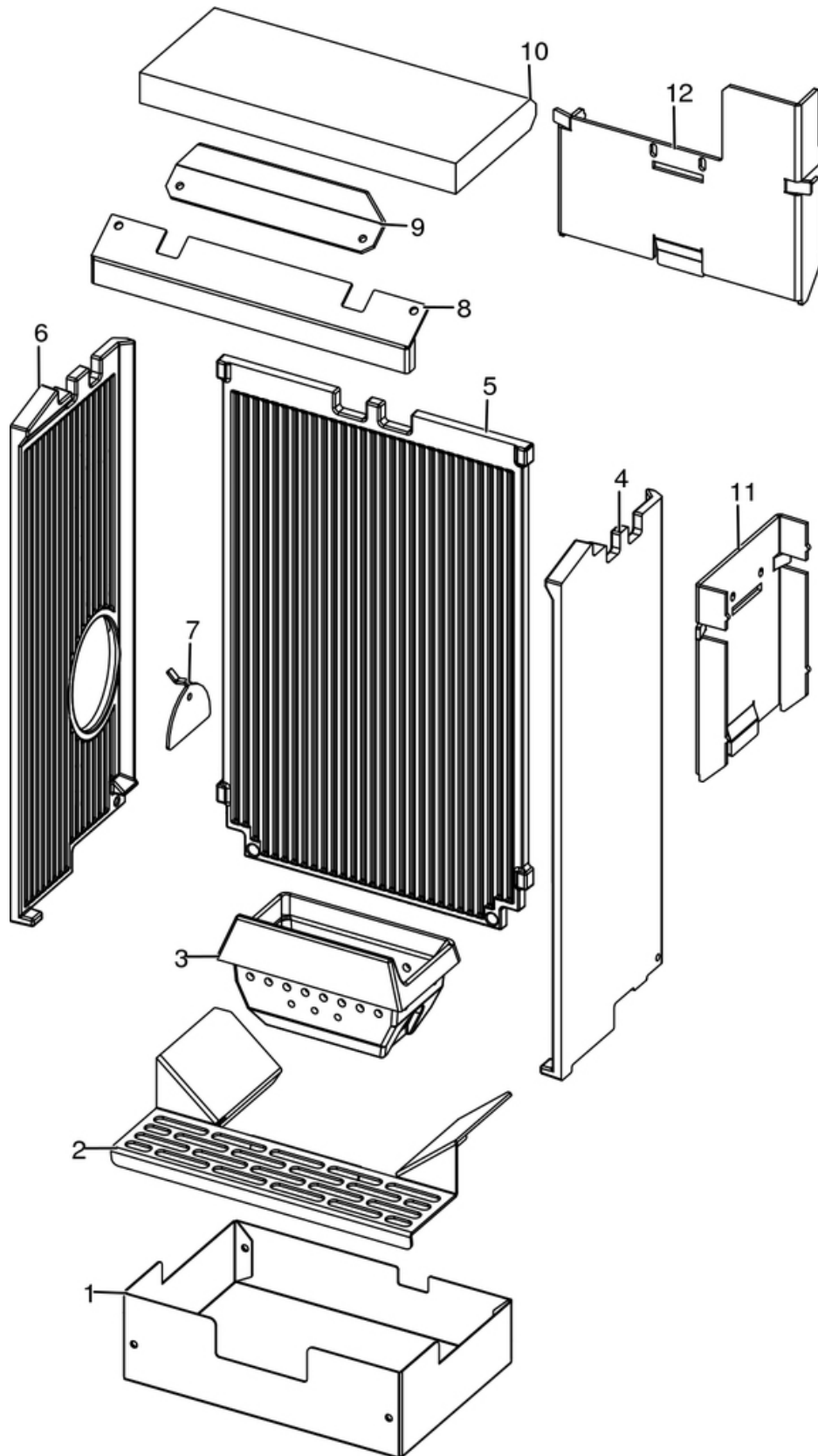

N°	Codice/Code	Descrizioni / Description / Beschreibung / Description / Descripcion
1	41401713930	Cassetto cenere / Ash drawer / Aschenkasten / Tiroir à cendres / Cajón ceniza
2	41411742230V	Griglia focolare / Fire box grille / Feuerstellenrost / Grille foyer / Rejilla hogar
3	4130170030100	Braciere ghisa / Cast iron brazier / Brennschale aus Guß / Brasero en fonte / Brasero de arrabio
4	41301700500V	Fianco destro in ghisa / Right cast iron side / Rechte Seite aus Guß / Coté droit en fonte / Placa lateral derecha de arrabio
5	41301700700V	Schiena in ghisa / Cast iron back / Rückwand aus Guß / Fond en fonte / Parte trasera de arrabio
6	41301700600V	Fianco sinistro in ghisa / Left cast iron side / Linke Seite aus Guß / Coté gauche en fonte / Placa lateral izquierda de arrabio
7	41411613530V	Deflettore pellet / Pellet deflector / Pellet Leitblech / Deflecteur pellet / Deflector pellet
8	41401854430	Deflettore pulizia vetro / Glass deflector / Leitblech der Scheibe / Déflecteur de la vitre / Deflector del cristal
9	41331702031	Protezione focolare inox / Inox fire protection / Feuerschutz aus Edelstahl / Protection foyer inox / Protección hogar inox
10	41151702000	Deflettore vermiculite / Vermiculite deflector / Leitblech aus Vermiculite / Déflecteur en vermiculite / Deflector en vermiculite
11	41411740231	Tappo lat. pulizia struttura / Lateral cap for structure cleaning / Seitlicher Stöpsel für Korpus Reinigung / Bouchon lateral pour nettoyage structure / Tapon lateral por limpieza estructura
12	41411740131	Tappo post. pulizia struttura / Rear cap for structure cleaning / Hinterer Stöpsel für Korpus Reinigung / Bouchon posterieur pour nettoyage structure / Tapon posterior por limpieza estructura

## LINEA COMFORT AIR 9 UP! M1

Porta fuoco / Fire door / Feuertür / Porte foyer / Puerta hogar

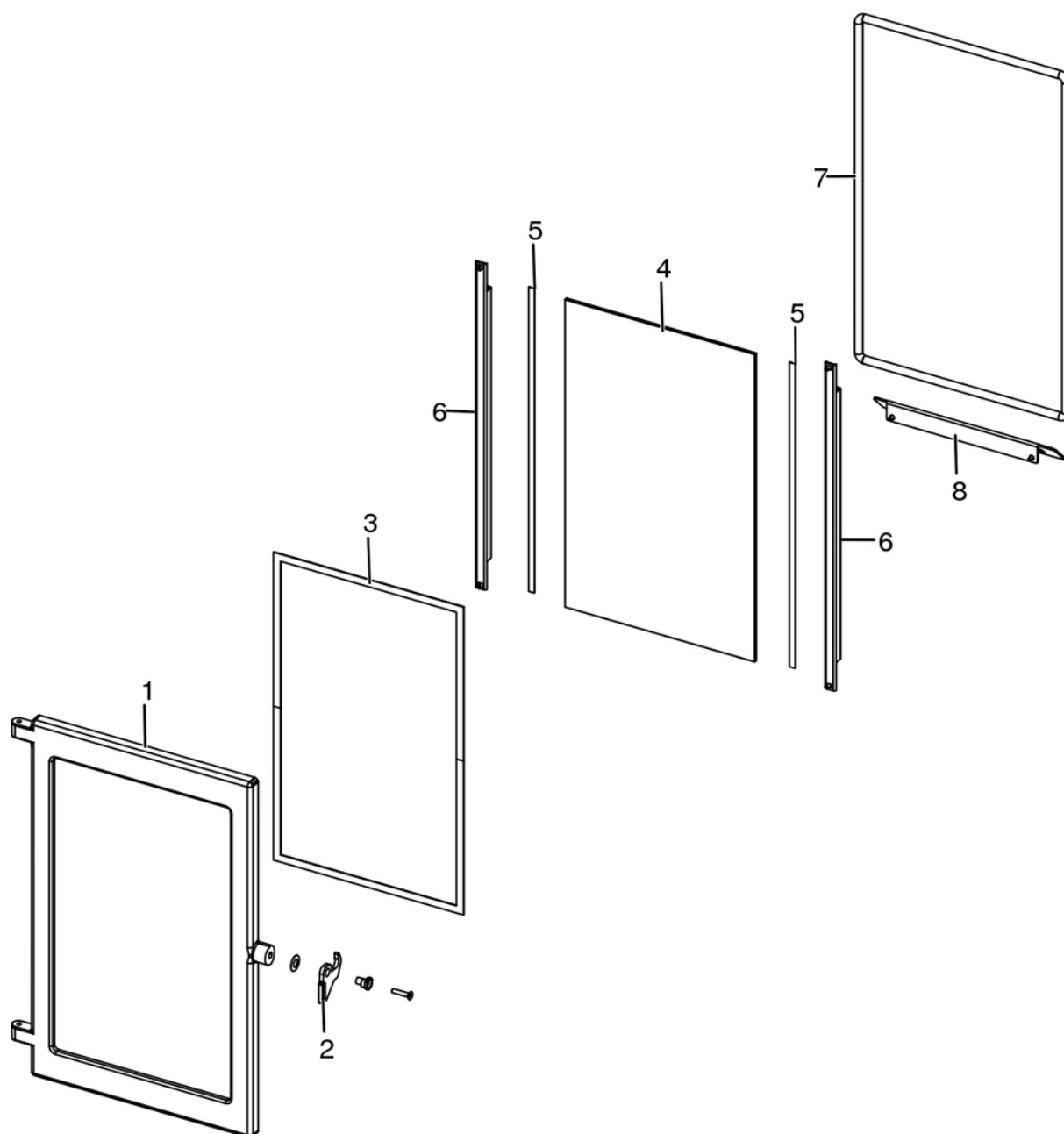

N°	Codice/Code	Descrizioni / Description / Beschreibung / Description / Descripción
1	41301700400V	Porta focolare ghisa / Cast iron fire door / Feuertür aus Guß / Porte foyer en fonte / Puerta hogar de arrabio
2	41411742161	Maniglia porta focolare / Fire door handle / Feuertür Griff / Poignée porte foyer / Tirador puerta fuego
3	41801603300A	Guarnizione Ø5 5mt / Gasket Ø5 5mt / Dichtung Ø5 5mt / Joint Ø5 5mt / Junta Ø5 5mt
3	41801603300B	Guarnizione Ø5 50mt / Gasket Ø5 50mt / Dichtung Ø5 50mt / Joint Ø5 50mt / Junta Ø5 50mt
3	41801603300C	Guarnizione Ø5 5mt + silicone / Gasket Ø5 5mt + silic / Dichtung Ø5 5mt + Silikon / Joint Ø5 5mt + silic / Junta Ø5 5mt
4	41701701800	Vetroceramico porta tecnica / Technical door glass / Glas für technische Tür / Vitrocéramique porte technique / Cristal cerámico puerta técnica
5	4120573A	Guarnizione a nastro 8 mm (5 mt.) per porta / Door strip gasket 8 mm (5 m) / Türbanddichtung 8 mm (5 m) / Joint ruban 8 mm (5 m) pour porte / Guarnición de cinta para puerta 8 mm (5 m)
5	4120573B	Guarnizione a nastro 8 mm (50 mt.) per porta / Door strip gasket 8 mm (50 m) / Türbanddichtung 8 mm (50 m) / Joint ruban 8 mm (50 m) pour porte / Guarnición de cinta para puerta 8 mm (50 m)



<b>6</b>	<b>4160170440000</b>	Profilo fermavetro / Fastening bracket profile / Haltebügel für Scheibebefestigung Profil / Profil patte de fixation / Perfil fermacristal
<b>7</b>	<b>4120104A</b>	Cordino fibroceramico Ø 12 mm (5 mt.) / Ceramic fibre cord Ø 12 mm (5 m.) / Keramikfaserschnur Ø 12 mm (5 m) / Cordon en fibre céramique Ø 12 mm (5 m) / Junta a cuerda de fibra cerámica Ø 12 mm (5 m)
<b>7</b>	<b>4120104B</b>	Cordino fibroceramico Ø 12 mm (50 mt.) / Ceramic fibre cord Ø 12 mm (50 m.) / Keramikfaserschnur Ø 12 mm (50 m) / Cordon en fibre céramique Ø 12 mm (50 m) / Junta a cuerda de fibra cerámica Ø 10 mm (52 m)
<b>7</b>	<b>41201041</b>	Kit sostituzione cordino (cordino+silicone) Ø 12 mm / Cord replacement kit (cord + silicon) Ø 12 mm / Schnuraustauschsatz (Schnur+Silikon) Ø 12 mm / Kit remplacement cordon (cordon + silicone) Ø 12 mm / Kit sustitución junta a cuerda (junta a cuerda+silicón) Ø 12 mm
<b>8</b>	<b>4141174203100</b>	Scivolo cenere / Ash ramp / Aschenrutsche / Glissière cendre / Tobogán ceniza

## LINEA COMFORT AIR 9 UP! M1

Gruppo caricamento pellet / Pellet feed group / Pellet Fördergruppe / Groupe chargement du pellet / Grupo de carga pellet

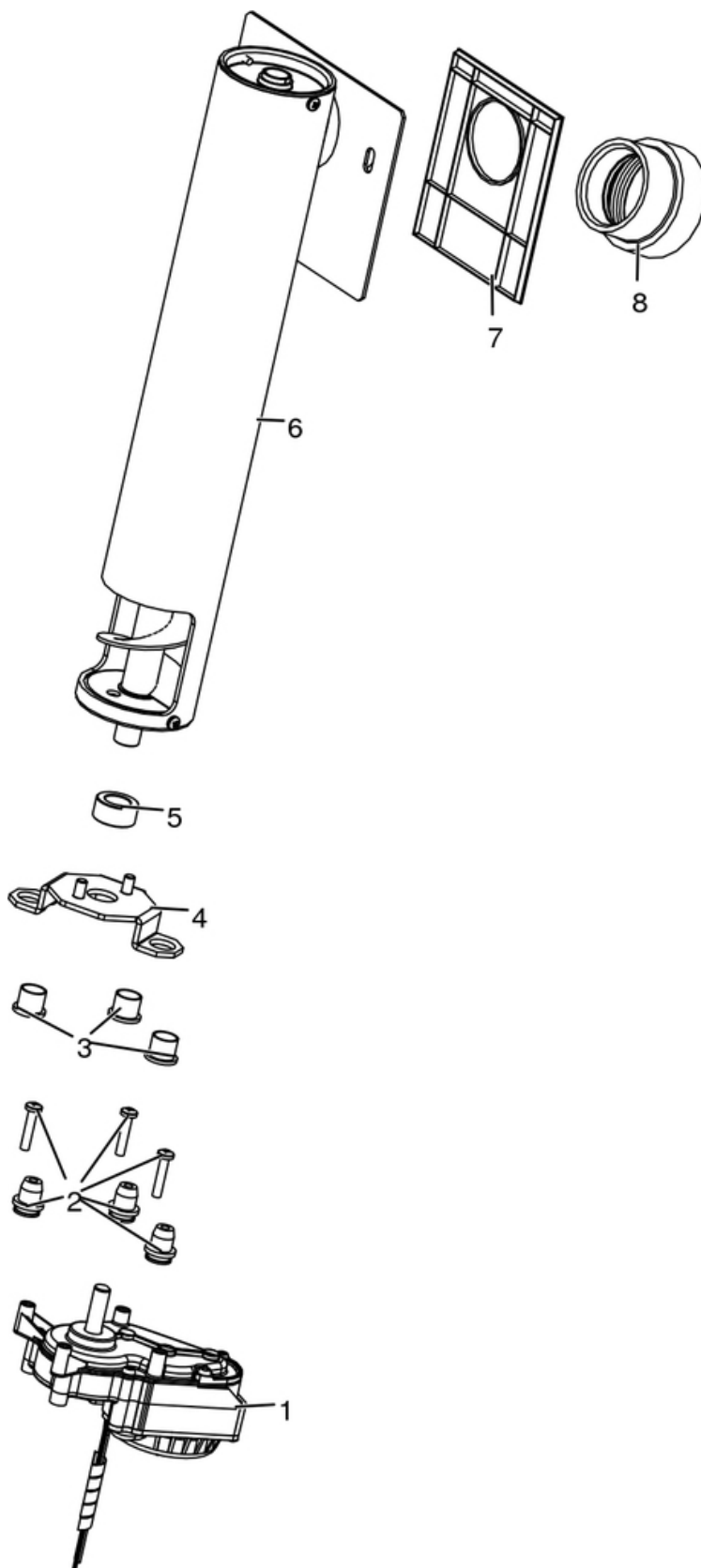

N°	Codice/Code	Descrizioni / Description / Beschreibung / Description / Descripción
1	41451702200	Motoriduttore brushless / Brushless reduction motor / Brushless Getriebemotor / Motoréducteur brushless / Motorreductor brushless
2	41801703700	Gommini antivibrante / Vibration damper rubber / Rammschutz Gummi / Caoutchouc antivibratoire / Cauchitos antivibración
3	41201800700	Boccola (3 pz) / Bushing (3 pcs) / Buchse (3 Stk) / Douille (3 pcs) / Abrazadera (3 pzs)
4	41411779331	Supporto coclea "Ragno" / Pellet feed screw bracket "spider" / "Spinne" Schenke Gestell / Support vis sans fin "Araignée" / Soporte coclea "Araña"
5	4120398	Connettore motoriduttore-coclea / Reduction motor-feed screw connector / Verbindung Getriebemotor-Schnecke / Connecteur motoréducteur-vis sans fin / Conector motorreductor-cóclea
6	41411741151	Alimentazione completa / Complete power / Komplette Anspeisung / Alimentation complète / Alimentacion completa
7	41801600400	Guarnizione gruppo caricamento / Gasket / Dichtung / Joint / Junta
8	41801702600	Disaccoppiatore mesc. Marrone / Brown disengaging device / Braun Verängungrohr / Tuyau de découplage maron / Tubo de desvio marron

## LINEA COMFORT AIR 9 UP! M1

Gruppo accensione / Ignition group / Entzündung Gruppe / Groupe d'allumage / Grupo ignición

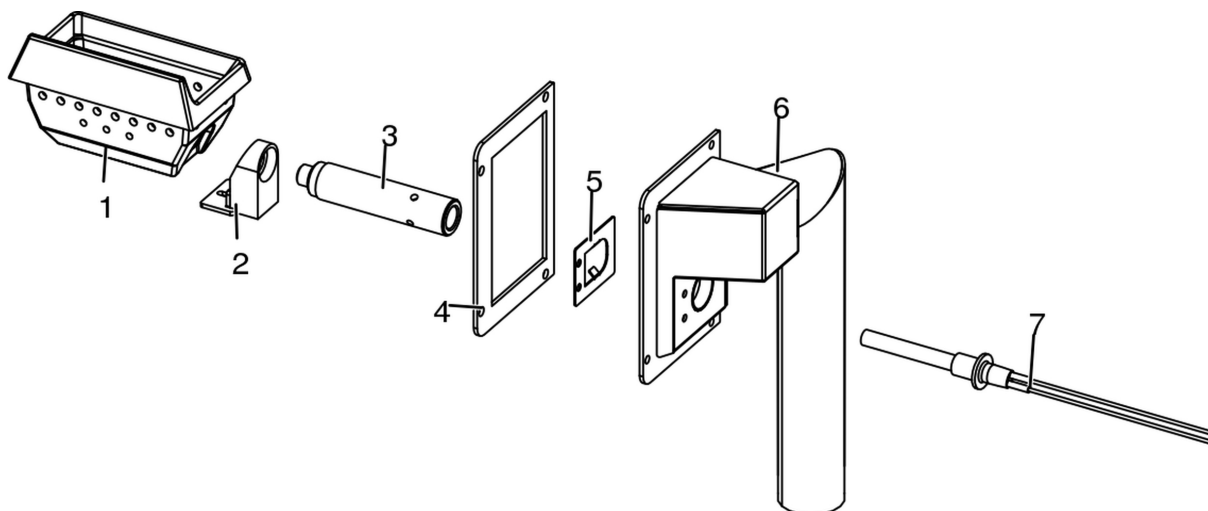

N°	Codice/Code	Descrizioni / Description / Beschreibung / Description / Descripción
1	4130170030100	Braciere ghisa / Cast iron brazier / Brennschale aus Guß / Brasero en fonte / Brasero de arrabio
2	41411741740V	Blocchetto / Little stop / Kleiner Stopper / Petit stop / Tope pequeno
3	41201705400	Condotto candelella / Sparkplug conduit / Zündkerzenkanal / Conduit bougie / Conducto bujía
4	41801702000	Guarnizione scatola / Box gasket / Gehäuse Dichtung / Joint de boite / Burlete caja
5	41401711131	Staffa a molla / Spring bracket / Federhalterung / Support à ressort / Soporte de resorte
6	41411741440V	Scatola aspirazione / Air inlet box / Lufteingangs Schachtel / Coffret entrée d'air / Caja entrada aire
7	41451308101	Candelella 315 Watt / Sparkplug 315 Watt / Zündkerze 315 Watt / Bougie 315 Watt / Bujía 315 Watt
7	41451308150	Kit 25 candelette 315 Watt / 25 Sparkplugs 315 Watt kit / Bausatz 25 Zündkerzen 315 Watt / Kit 25 Bougies 315 Watt / Kit 25 Bujías 315 Watt

## LINEA COMFORT AIR 9 UP! M1

Porta cenere / Ash door / Ashentür / Porte cendre / Puerta ceniza

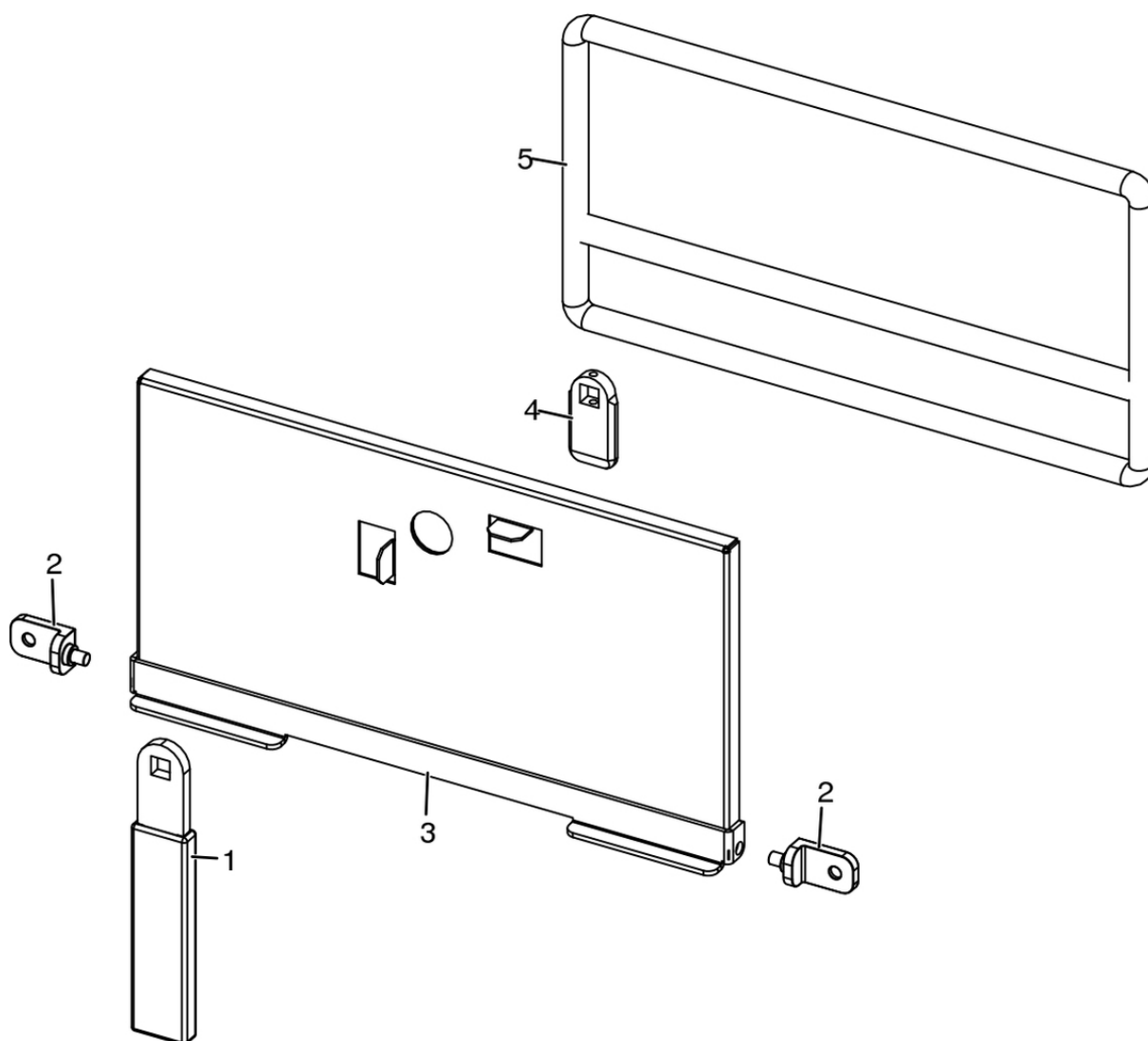

N°	Codice/Code	Descrizioni / Description / Beschreibung / Description / Descripción
1	41411621600	Maniglia con impugnatura porta cenere / Handle / Griff / Poignée / Tirador
2	41411623740V	Cerniera acciaio porta cenere / Ash compartment door steel hinge / Aschenklappe Stahlscharnier / Charnier en acier porte compartiment cendre / Bisagra en acero puerta compartimento cenizas
3	4141189404000	Telaio porta cenere / Ash door frame / Cadre porte de cendre / Aschentürrahmen / Marco puerta ceniza
4	41201608400	Serratura porta cassetto cenere / Door lock for ash drawer / Türschloss für Aschenkasten / Serrure de porte du tiroir à cendres / Cerradura puerta cajón ceniza
5	412007003A	Cordino fibroceramico Ø 14 mm (5 mt.) / Ceramic fibre cord Ø 14 mm (5 m.) / Keramikfaserschnur Ø 14 mm (5 m) / Cordon en fibre céramique Ø 14 mm (5 m) / Junta a cuerda de fibra cerámica Ø 14 mm (5 m)
5	412007003B	Cordino fibroceramico Ø 14 mm (50 mt.) / Ceramic fibre cord Ø 14 mm (50 m.) / Keramikfaserschnur Ø 14 mm (50 m) / Cordon en fibre céramique Ø 14 mm (50 m) / Junta a cuerda de fibra cerámica Ø 14 mm (50 m)
5	412007003C	Kit sostituzione cordino (cordino+silicone) Ø 14 mm / Cord replacement kit (cord + silicon) Ø14 mm / Schnuraustauschsetz (Schnur +Silikon) Ø 14 mm / Kit remplacement cordon (cordon+silicon) Ø 14 / Kit sustitución junta a cuerda (junta a cuerda+silicón) Ø 14 mm

## LINEA COMFORT AIR 9 UP! M1

Gruppo aria comburente / Combustion air group / Verbrennungsluft Gruppe / Groupe air comburant / Grupo aire comburente

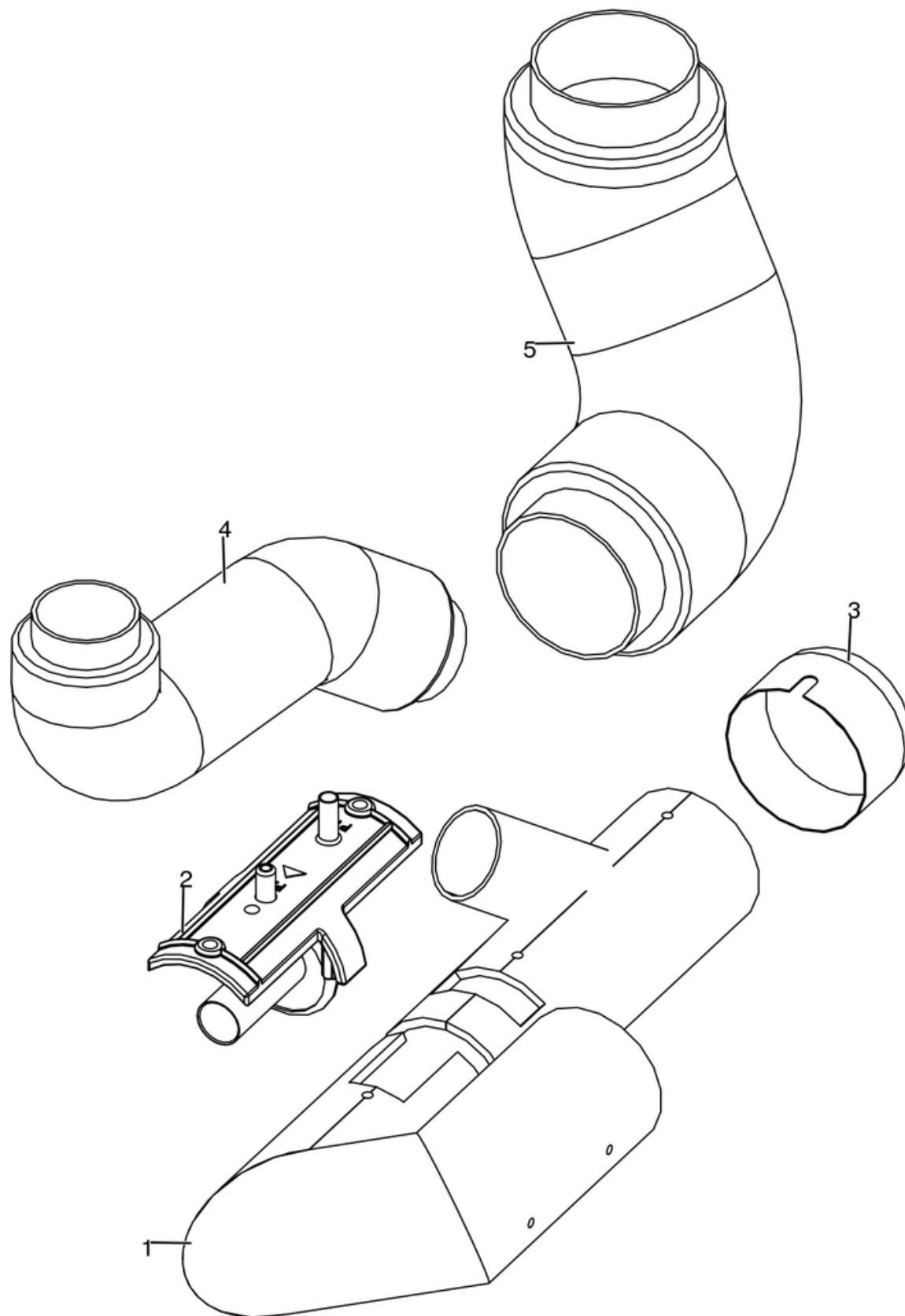

N°	Codice/Code	Descrizioni / Description / Beschreibung / Description / Descripción
1	41601703360	Tubo aspirazione zincato / Zinc-coated air inlet pipe / Verzinkter Lufteingangsrohr / Tuyau entrée d'air galvanisé / Tubo entrada aire cincando
2	41601301850	Componente rilevamento portata aria / Air flow measure component / Bauteil für Messung der Luftmenge / Composent pour la mesuration de la quantité d'air / Componente por la medida de l'aire
3	41401036100	Filtro antipolvere / Anti-dust filter / Staubschutzfilter / Filtre antipoussière / Filtro de protección polvo
4	41801601900	Tubo aspirazione pulizia vetro / Inlet pipe for cleaning glass air / Glassreinigungs Lufteingangsrohr / Tuyau entrée pour l'aire de nettoyage du vitre / Tubo entrada por l'aire de limpieza vidrio
5	41801601700	Tubo aspirazione camera combustione / Combustion chamber aspiration tube / Verbrennungskammer Förderrohr / Tuyau aspiration air chambre de combustion / Tubo aspiración aire cámara de combustión

## LINEA COMFORT AIR 9 UP! M1

Gruppo elettrico ed elettronico / Electrical and electronic group / Elektrische und elektronische Gruppe / Groupe électrique et électronique / Grupo eléctrico y electrónico

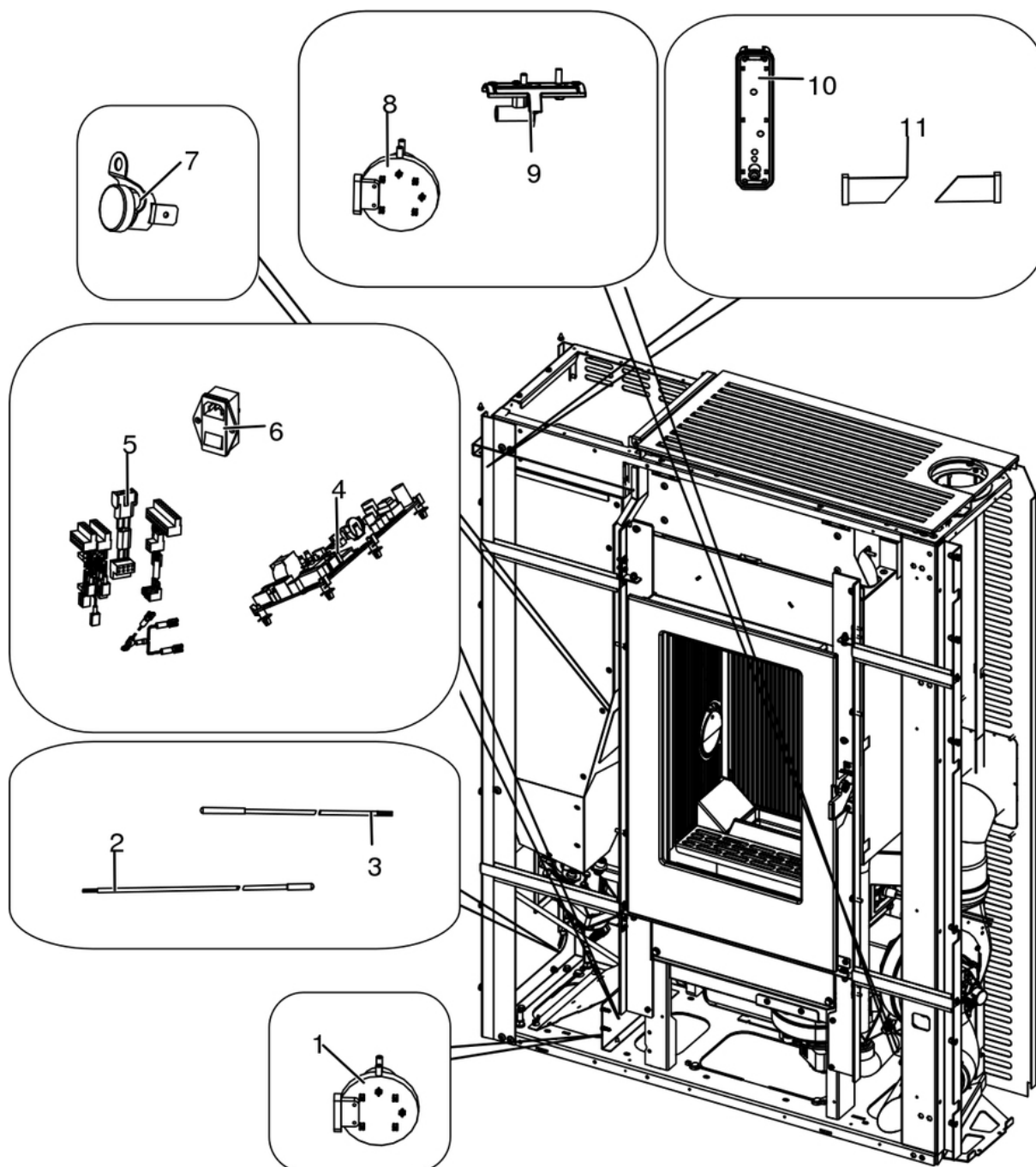

N°	Codice/Code	Descrizioni / Description / Beschreibung / Description / Descripción
1	41451303400	Trasduttore di pressione / Pressure transducer / Active-Wandler / Transducteur de pression / Transductor de pression
1	4120631A	Tubicino silicónico - 5m / Silicon tube - 5m / Silikonrohr - 5m / Petit tuyau en silicone - 5m / Tubo silicónico - 5m
2	41451703600	Sonda fumi con flangia con morsettiera L.980 / Smoke sensor with flange with terminal board L.980 / Rauchsonde mit Flansche mit Klemmenbrett L.980 / Sonde fumées avec bride avec serre-câble L.980 / Sonda humos con brida con borne L.980
3	4160386	Sonda temperatura ambiente/acqua / Room/Water temperature sensor / Raum- Wassertemperaturfühler / Sonde température ambiance/eau / Sonda temperatura ambiente/agua
4	41451802200	Scheda elettronica / Electronic board / Elektronische Platine / Carte électronique / Tarjeta electronica



<b>5</b>	<b>41451801000</b>	Cablaggio / Wiring / Verdrahtung / Cablage / Cableado
<b>5</b>	<b>41452000500</b>	Cavo motoriduttore / Reduction motor cable / Kabel Getriebemotor / Câble motoréducteur / Cable motorreductor
<b>6</b>	<b>4160193</b>	Pulsante accensione / On/Off button / Zündungstaste / Touche d'allumage / Botón encendido
<b>7</b>	<b>412007004</b>	Clickson 110°C / Clickson 110°C / Clickson 110°C / Clickson 110°C / Clickson 110°C
<b>8</b>	<b>41451003700</b>	Pressostato / Pressure switch / Druckschalter / Pressostat / Presostato
<b>8</b>	<b>4120631A</b>	Tubicino siliconico - 5m / Silicon tube - 5m / Silikonrohr - 5m / Petit tuyau en silicone - 5m / Tubo silicónico - 5m
<b>9</b>	<b>41601301850</b>	Componente rilevamento portata aria / Air flow measure component / Bauteil für Messung der Luftmenge / Composent pour la mesuration de la quantité d'air / Componente por la medida de l'aire
<b>9</b>	<b>4120631A</b>	Tubicino siliconico - 5m / Silicon tube - 5m / Silikonrohr - 5m / Petit tuyau en silicone - 5m / Tubo silicónico - 5m
<b>10</b>	<b>41451602802</b>	Pannello di emergenza Wireless / Wireless emergency display / Wireless Notfall-Blende / Panneau d'urgence wireless / Panel emergencia wireless
<b>11</b>	<b>41451801600</b>	Cavo flat 20 vie L.600 mm / Flat cable 20 pin L.600 mm / Flat-Kabel 20polig L.600 mm / Cable flat 20 voies L.600 mm / Flat cable 20 vias L.600 mm

## LINEA COMFORT AIR 9 UP! M1

Gruppo ventilazione / Ventilation group / Lüftungsgruppe / Groupe de ventilation / Grupo de ventilación

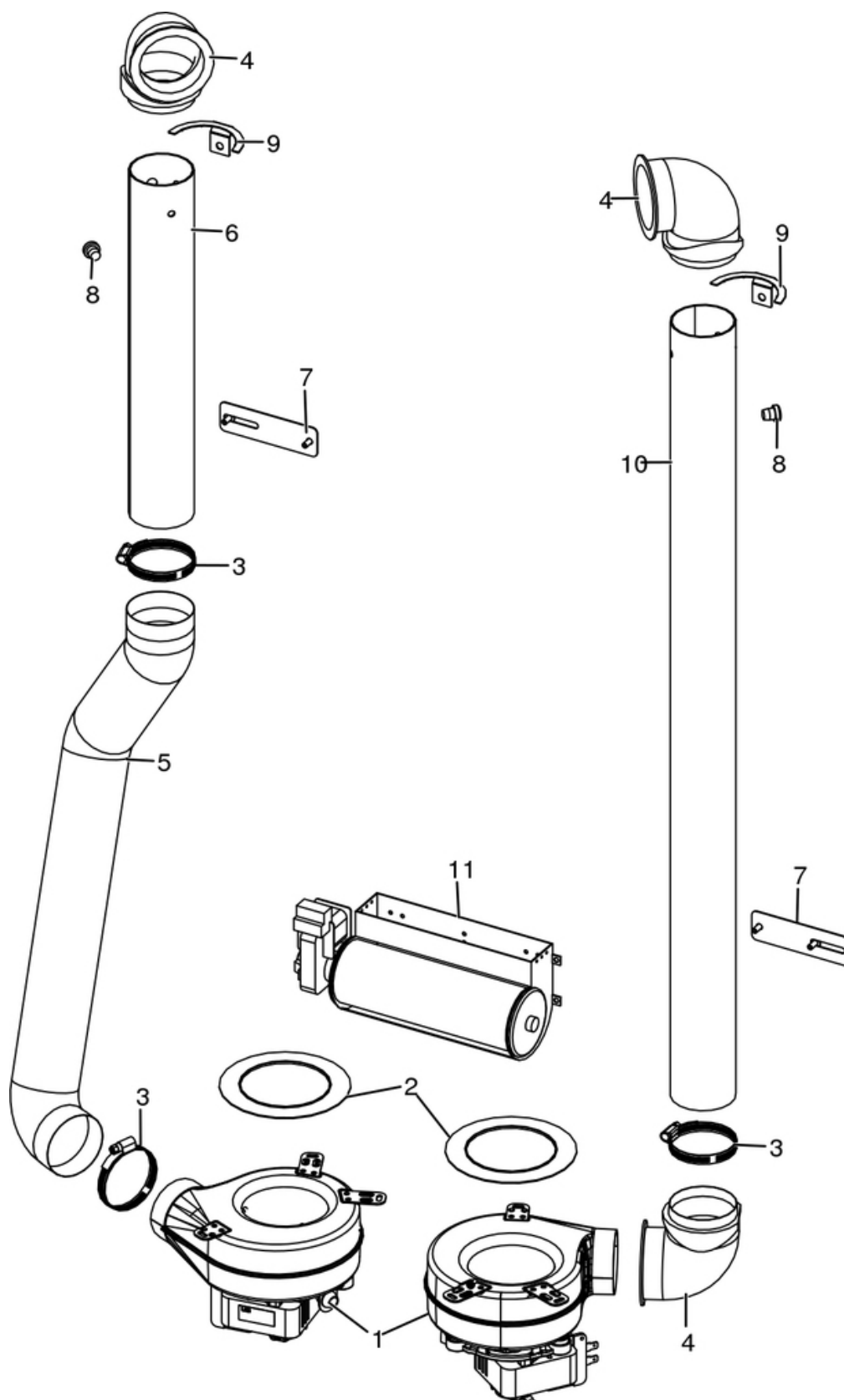

N°	Codice/Code	Descrizioni / Description / Beschreibung / Description / Descripcion
1	41451503300	Ventilatore centrifugo / Air fun / Lufgebläse / Ventilateur air / Ventilador aire
2	41801601600	Guarnizione ventilatore / Fan gasket / Dichtung des Gebläses / Joint du ventilateur / Junta ventilador
3	41200902000	Fascette Ø 64-76 mm (2 pz) / Clamps Ø 64-76 mm (2 pcs) / Rohrschellen Ø 64-76 mm (2 Stck) / Colliers Ø 64-76 mm (2 pcs) / Bandas Ø 64-76 mm (2 pzs)
4	41601003600	Tubo 90° / Pipe 90° / Rohr 90° / Tuyau 90° / Tubo 90°
5	4009003	Tubo flessibile Ø 60 mm lunghezza 1,5 m / Flex pipe Ø 60 mm lenght 1,5 m / Schlauch Ø 60 mm Länge 1,5 m / Tuyau flexible Ø 60 mm longueur 1,5 m / Tubo flexible Ø 60 mm lungueza 1,5 m
5	4009017	Tubo flessibile Ø 60 mm lunghezza 8 m / Flex pipe Ø 60 mm lenght 8 m / Schlauch Ø 60 mm Länge 8 m / Tuyau flexible Ø 60 mm longueur 8 m / Tubo flexible Ø 60 mm lungueza 8 m
6	41601703260	Tubo aria Ø 60 corto zincato / Short zinc-coated air pipe Ø 60 / Kurz verzinkter Luftrohr Ø 60 / Tuyau air galvanisé court Ø 60 / Tubo aire cincado corto Ø 60
7	41401711610	Staffa blocco tubo aria / Air pipe blocking bracket / Luftrohr Bügel / Étrier blocage du tuyau air / Abrazadera bloqueado de tubo aire
8	4120180	Gommini paracolpi (4 pz) / Rubber bumpers (4 pcs.) / Schlagschutzgummi (4 Stck) / Pièces caoutchouc antichoc (4 pcs) / Cauchitos anti-golpes (4 pz)
9	41401711730	Staffa fissaggio curve 90° / Fixing bracket for 90° bend / Haltebügel Verlauf 90° / Étrier fixation coude 90° / Abrazadera fijacion curva 90°
10	41601703160	Tubo aria Ø 60 lungo zincato / Long zinc-coated air pipe Ø 60 / Lang verzinkter Luftrohr Ø 60 / Tuyau air galvanisé long Ø 60 / Tubo aire cincado largo Ø 60
11	41451800900	Ventilatore tangenziale / Warm air fan / Luftgebläse / Ventilateur air / Ventilador aire

## LINEA COMFORT AIR 9 UP! M1

Gruppo fumi / Smoke group / Rauchgruppe / Groupe fumées / Grupo de humos

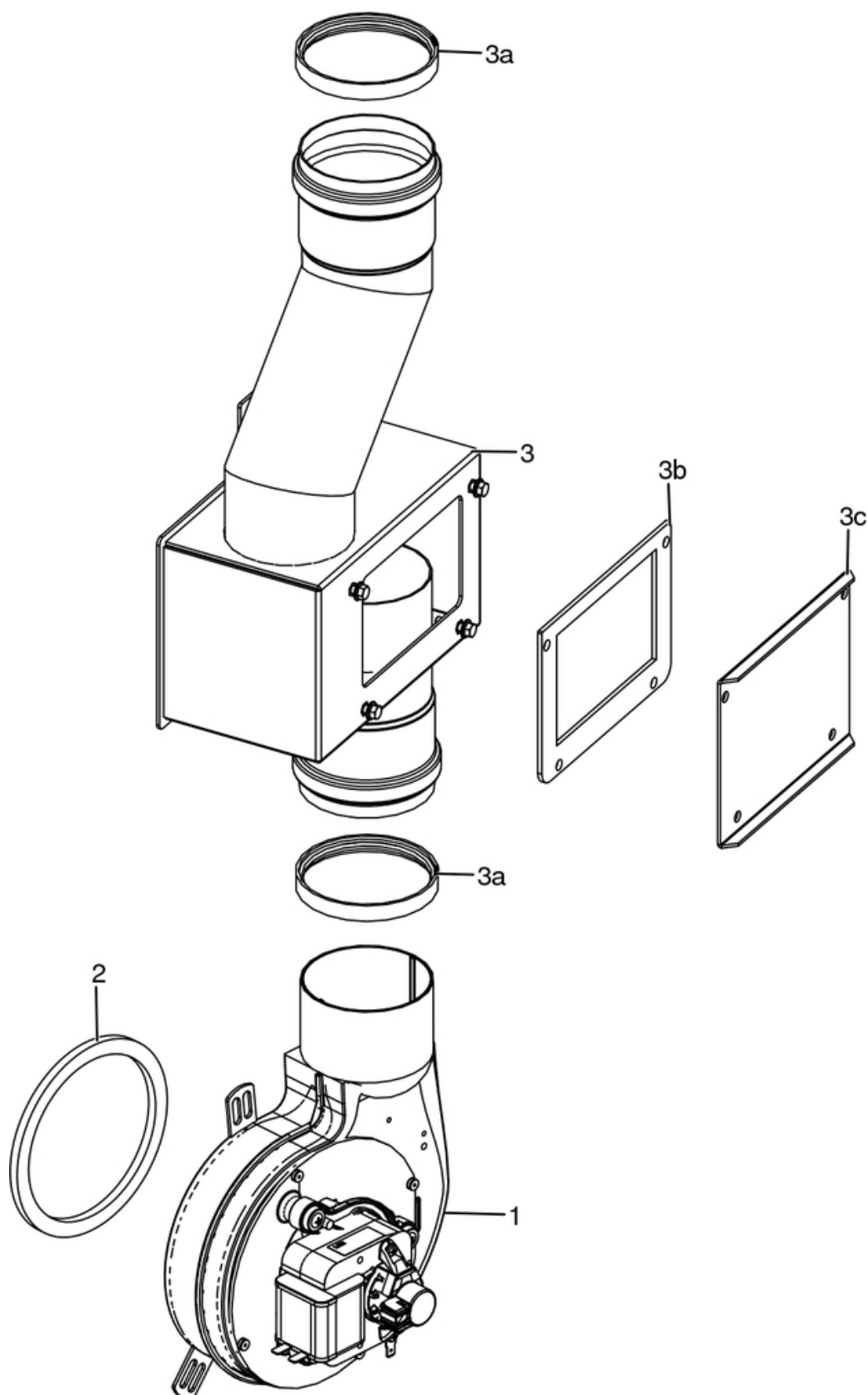

N°	Codice/Code	Descrizioni / Description / Beschreibung / Description / Descripción
1	41451406501	Ventilatore fumi / Smoke exhausted fan / Rauchgasgebläse / Ventilateur fumées / Ventilador humos
1	41801002600	Guarnizione adesiva voluta fumi / Adhesive gasket smoke volute / Haftendichtung Rauchvolute / Joint adhesive volute fumées / Junta adhesiva voluta humos
1	41451209300	Encoder per ventilatore fumi marchi LN2/SIT / Encoder for LN2/SIT smoke fan / Encoder für LN2/SIT Rauchgasgebläse / Encoder pour ventilateur des fumées marques LN2/SIT / Encoder para ventilador humos marcas LN2/SIT
1	41452009200	Encoder ventilatore / Fan encoder / Lüfter Encoder / Encodeur de ventilateur / Codificador de ventilador
2	41801599850	Kit 50 guarnizioni / Kit 50 gaskets / Bausatz 50 Dichtungen / Kit 50 joints / Kit 50 juntas
3	41411800251	Scatola fumi / Fumes box / Rauchabzug / boîte à fumée / Caja humos
3a	40120969	Guarnizione silicone (5pz) / Silicone Gasket (5pc.) / Silikondichtung (5 St.) / Joint en silicone / Junta en silicona
3b	41801702000	Guarnizione scatola / Box gasket / Gehäuse Dichtung / Joint de boite / Burlete caja
3c	41401800430	Tappo scatola fumi / Plug fume box / Klappe Rauchabzug / Clapet boîte à fumée / Tapon caja de humos