

EGO HYDROMATIC 12 M1

Gruppo estetico / Aesthetic group / Aesthetische Gruppe / Groupe esthétique / Grupo estético

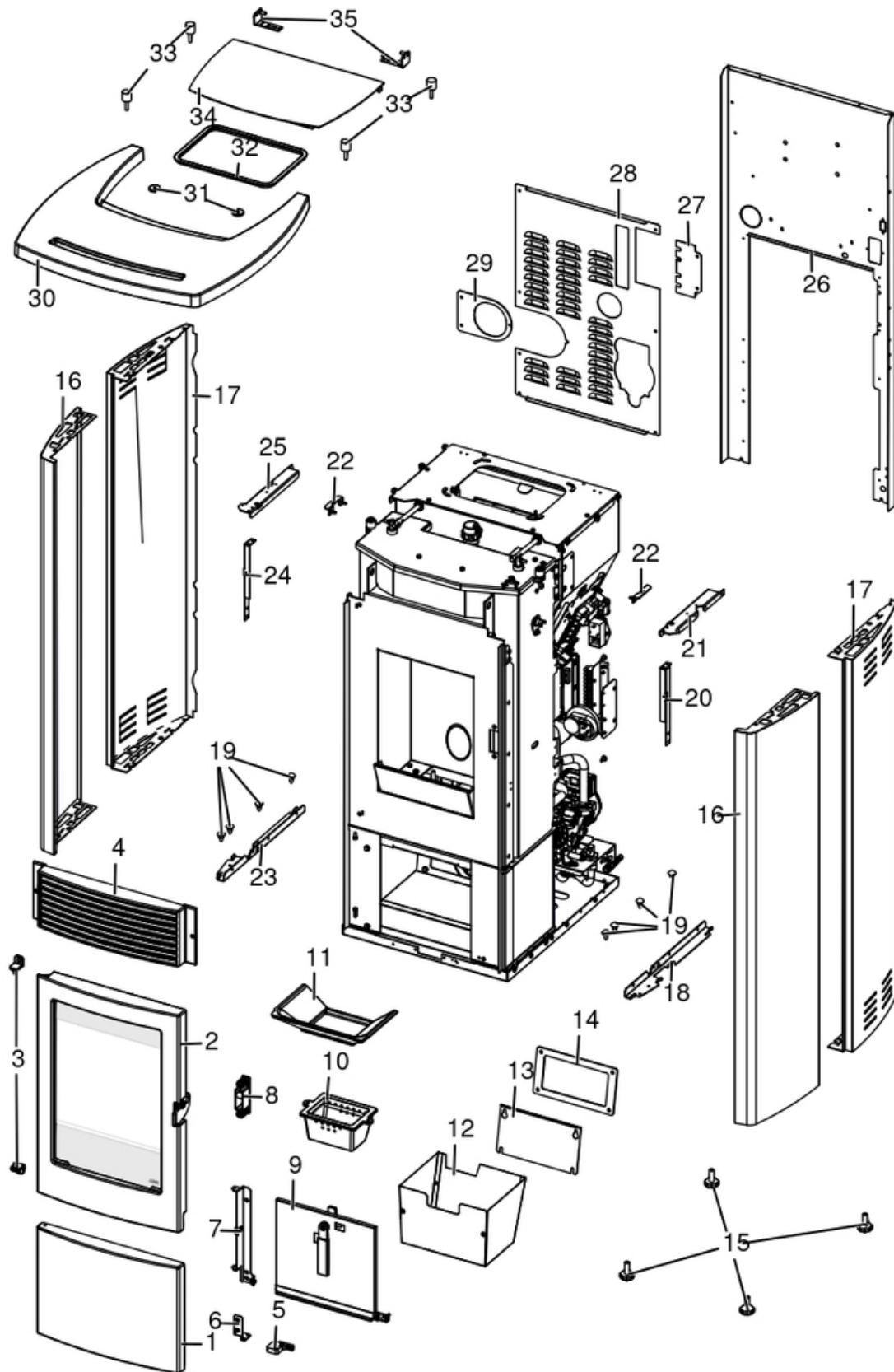

N°	Codice/Code	Descrizioni / Description / Beschreibung / Description / Descripcion
1	41301600300V	Frontalino inferiore in ghisa / Lower filler / Untere Stopfung / Plaque inférieure en fonte / Tapa inferior de arrabio
2	437017031	Porta focolare / Fireplace door / Feuerstelle Tür / Porte foyer / Puerta hogar
3	412008063	Cerniere porta fuoco (2 pz) / Fire door hinge (2pcs) / Scharnier Feuertür (2 Stck) / Charnière porte foyer (2 pcs) / bisagra puerta del hogar (2 pz)
4	41301302100V	Griglia aria ghisa / Cast iron air outlet grille / Warmluftgitter aus Guss / Grille air chaud en fonte / Rejilla salida aire de arrabio
5	41201305100	Chiusura a spinta / Push-pull pressure closing / Druckschließung / Fermeture par pression / Cierre a presión
6	41401626830	Supporto chiusura a spinta / Push-pull pressure closing support / Unterstützung der Druckschließung / Support de la fermeture par pression / Apoyo de la cierre a presión
7	41411668640V	Supporto sportello / Door bracket / Türträger Klappe / Etrier porte / Soporte puerta
8	41411599950	Kit serratura ammortizzato / Pressur relief kit / Bausatz Überdruckablauf Brennkammer / Kit deocompression chambre comcusion / Kit decompression camara combustion
9	437017039	Porta cenere / Ash drawer door / Tür des Aschenkastens / Porte tiroir à cendres / Puerta cajón ceniza
10	41301601100V	Braciere ghisa autopulente / Self-cleaning cast iron grate / Selbstreinigend Brennertopf aus Gusseisen / Brasero en fonte autonettoyant / Brasero en arrabio autolimpiador
11	41301601200V	Scivolo braciere ghisa autopulente / Self-cleaning grate amp / Selbstreinigend Brennertopf Rutsche / Glissière brasero autonettoyant / Tobogán brasero autolimpiador
12	437016041	Cassetto cenere / Ash drawer / Aschenkasten / Tiroir à cendres / Cajón ceniza
13	41401605530	Tappo camera fumi zincato / Smoke compartment galvanized plug / Verzinktes Rauchabzugklappe / Join zingué compartiment fumées / Tapón galvanizado compartimento humos
14	41801601300	Guarnizione tappo camera fumi / Smoke compartment plug gasket / Dichtung Rauchabzugklappe / Joint clapet compartiment fumées / Junta tapón compatimento humos
15	41201702400	Piedino (4 pz) / Feet (4 Pcs) / Füße (4 Stck.) / Vérins (4 P.Ces.) / Pies (4 piezas)
16	6914018	Rivestimento completo Dark / Complete Dark cladding / Komplette Verkleidung Dark / Habillage complète Dark / Revestimiento completo Dark
16	6914019	Rivestimento completo White / Complete White cladding / Komplette Verkleidung White / Habillage complète White / Revestimiento completo White
16	6914020	Rivestimento completo Bordeaux / Complete Burgundy cladding / Komplette Verkleidung Bordeaux / Habillage complète Bordeaux / Revestimiento completo Burdeos
16	6914021	Rivestimento completo Inox / Complete Stainless Steel cladding / Komplette Verkleidung Inox / Habillage complète Inox / Revestimiento completo Inox
16	6914034	Rivestimento completo Silver / Complete Silver cladding / Komplette Verkleidung Silver / Habillage complète Silver / Revestimiento completo Silver
17	41401425060	Fianco posteriore nero / Black rear side / Schwarze hintere Seite / Côté postérieur noir / Placa lateral posterior
18	41401627430	Staffa inferiore fianco dx / Lower R. bracket / Hunterer Halterung R. / Support inférieur D. / Soporte inferior DCHO
19	41801002300	Paracolpi in silicone Ø 8/5 (2pz) / Silicone bumpers Ø 8/5 (2pcs) / Schlagschutzgummi Ø 8/5 (2 Stck) / Pièces silicone antichoc Ø 8/5 (2pcs) / Anti-golpes en silicona Ø 8/5 (2pzs)
20	41411712230V	Supporto DX griglia / RH grille support / Rechte Rost Halterung / Support droit grille / Soporte DRCH rejilla
21	41411712130V	Supporto destro fianco / Right side support / Rechte Seitenhaltebügel / Support droit coté / Soporte DCHO lato
22	41401702930	Staffa fissaggio fianchi / Sides fixing bracket / Haltebügel für Seite / Étrier fixation cotés / Abrazadera fijacion fianco
23	41401627330	Staffa inferiore fianco sx / Lower L. bracket / Hunterer Halterung L. / Support inférieur G. / Soporte inferior IZDO
24	41411712430V	Supporto SX griglia / RH grille support / Linke Rost Halterung / Support gauche grille / Soporte IZQD rejilla
25	41411712330V	Supporto sinistro fianco / Left side support / Linke Seitenhaltebügel / Support gauche coté / Soporte IZDO lato
26	41401901830	Schienale / Rear back / Rückwand / Dos / Espalda
27	41411610231P	Copri morsettiera / Terminal board cover / Klemmenbrettdeckung / Couverture bornier / Cubierta de la placa terminal
28	41401901730	Pannello posteriore / Rear back / Rückwand / Dos / Espalda
29	41401702810	Supporto tubi fumi / Fumes pipes support / Stütze Rohr / Support tuyeaux fumés / Soporte tubos humos
30	4130130180200	Top in ghisa / Cast iron top / Topplatte aus Guß / Dessus en fonte / Top de arrabio
31	41801657900	Magneti (pz.2) / Magnet (pcs.2) / Magnet (stk. 2) / Aimant (pcs.2) / Imán (pz.2)
32	41801504700	Guarnizione tenuta serbatoio / Pellet hopper gasket / Pelletbehälter Dichtung / Joint réservoir pellet / Junta depósito pellet
33	41201501900	Antivibranti (10 pz) / Anti-vibration mountings (10 pcs) / Schwingungsdämpfend (10 Stck.) / Eléments antivibrations (10 pcs) / Anti-vibraciones (10 pzs)
34	41411668840P	Coperchio serbatoio pellet con guarnizione / Pellet hopper cover with gasket / Deckel Pelletbehälter mit dichtung / Couvercle réservoir pellet avec joint / Tapadera depósito con junta

35

4141187653000

Cerniera coperchio / Cover hinge / Abdeckscharnier / Charnière couvercle / Bisagra de la tapa

EGO HYDROMATIC 12 M1

Porta fuoco / Fire door / Feuertür / Porte foyer / Puerta hogar

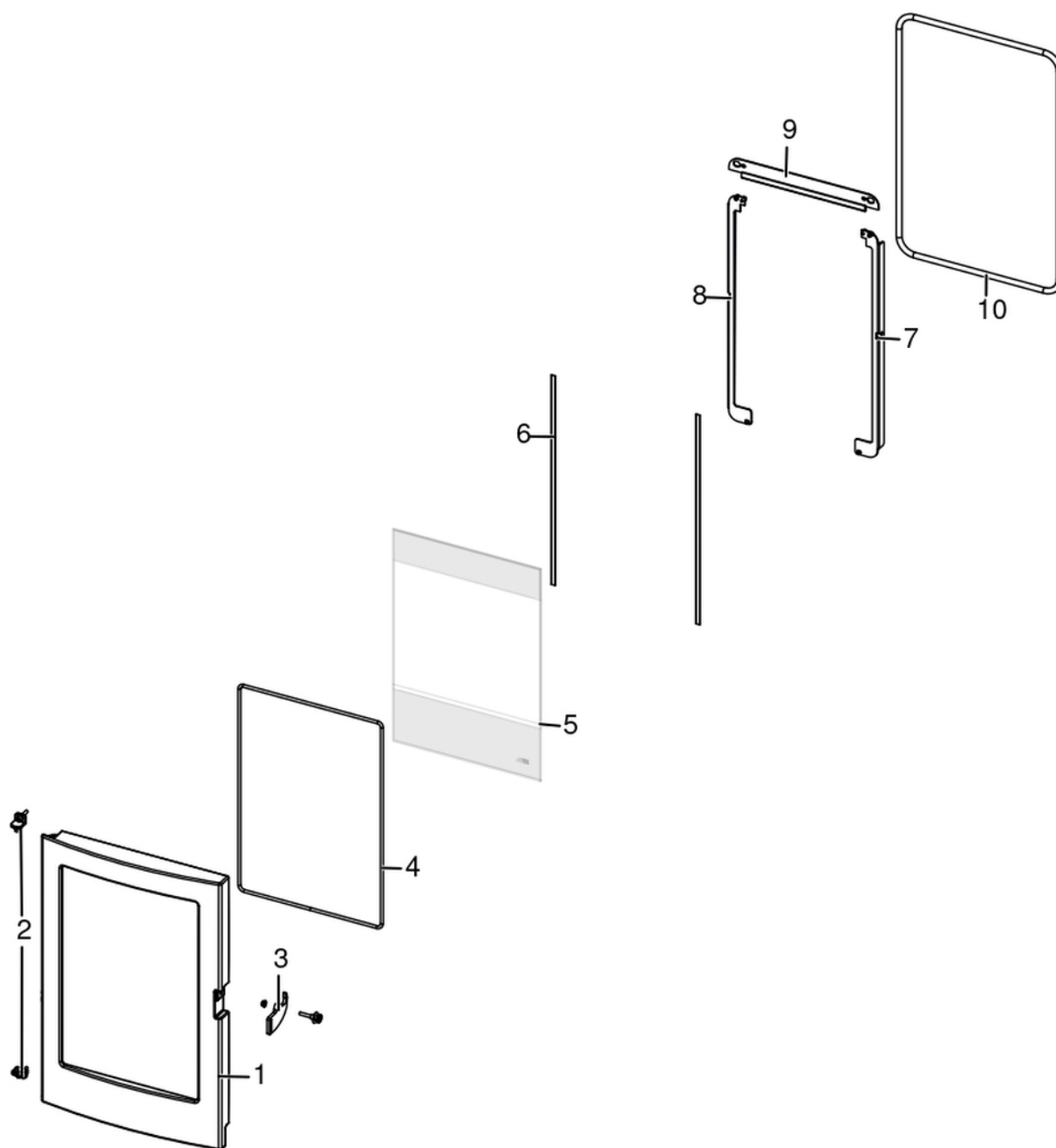

N°	Codice/Code	Descrizioni / Description / Beschreibung / Description / Description
1	41301302201V	Porta in ghisa nera / Black cast iron door / Schwarze Tür aus Gusseisen / Porte en fonte noire / Puerta de arrabio negra
2	412008063	Cerniere porta fuoco (2 pz) / Fire door hinge (2pcs) / Scharnier Feuertür (2 Stck) / Charnière porte foyer (2 pcs) / bisagra puerta del hogar (2 pz)
3	41401424160	Maniglia completa / Complete handle / Kompletter Griff / Poignée complète / Tirador completo
4	41801603300A	Guarnizione Ø5 5mt / Gasket Ø5 5mt / Dichtung Ø5 50mt / Joint Ø5 50mt / Junta Ø5 5mt
4	41801603300B	Guarnizione Ø5 50mt / Gasket Ø5 50mt / Dichtung Ø5 50mt / Joint Ø5 50mt / Junta Ø5 50mt
4	41801603300C	Guarnizione Ø5 5mt + silicone / Gasket Ø5 5mt + silic / Dichtung Ø5 5mt + Silikon / Joint Ø5 5mt + silic / Junta Ø5 5mt
5	41701700161	Vetroceramico con serigrafia / Ceramic glass / Glaskeramikscheibe / Vitre céramique / Cristal cerámico
6	4120572A	Guarnizione a nastro 6 mm (5 mt.) per porta / Door strip gasket 6 mm (5 m) / Türbanddichtung 6 mm (5 m) / Joint ruban 6 mm (5 m) pour porte / Guarnición de cinta para puerta 6 mm (5 m)

6	4120572B	Guarnizione a nastro 6 mm (50 mt.) per porta / Door strip gasket 6 mm (50 m) / Türbanddichtung 6 mm (50 m) / Joint ruban 6 mm (50 m) pour porte / Guarnición de cinta para puerta 6 mm (50 m)
7	4141170953000	Profilo fermavetro DX / RH Fastening bracket profile / Haltebügel für Scheibebefestigung Profil Rechts / Profil patte de fixation droite / Perfil fermacristal derecho
8	4141170963000	Profilo fermavetro SX / LH Fastening bracket profile / Haltebügel für Scheibebefestigung Profil Links / Profil patte de fixation gauche / Perfil fermacristal izquierdo
9	4141171153100	Profilo tamponazione porta nero / Door filler frame / Türstopfung Profil / Profil tampon porte / Perfil taponado puerta
10	4120103A	Cordino fibroceramico Ø 10 mm (5 mt.) / Ceramic fibre cord Ø 10 mm (5 m) / Keramikfaserschnur Ø 10 mm (5 m) / Cordon en fibre céramique Ø 10 mm (5 m) / Junta a cuerda de fibra cerámica Ø 10 mm (5 m)
10	4120103B	Cordino fibroceramico Ø 10 mm (50 mt.) / Ceramic fibre cord Ø 10 mm (50 m) / Keramikfaserschnur Ø 10 mm (50 m) / Cordon en fibre céramique Ø 10 mm (50 m) / Junta a cuerda de fibra cerámica Ø 10 mm (50 m)
10	41201031	Kit sostituzione cordino (cordino+silicone) Ø 10 mm / Cord replacement kit (cord + silicon) Ø 10 mm / Schnuraustauschsatz (Schnur+Silikon) Ø 10 mm / Kit remplacement cordon (cordon + silicone) Ø 10 mm / Kit sustitución junta a cuerda (junta a cuerda+silicón) Ø 10 mm

EGO HYDROMATIC 12 M1

Porta cenere / Ash door / Ashentür / Porte cendre / Puerta ceniza

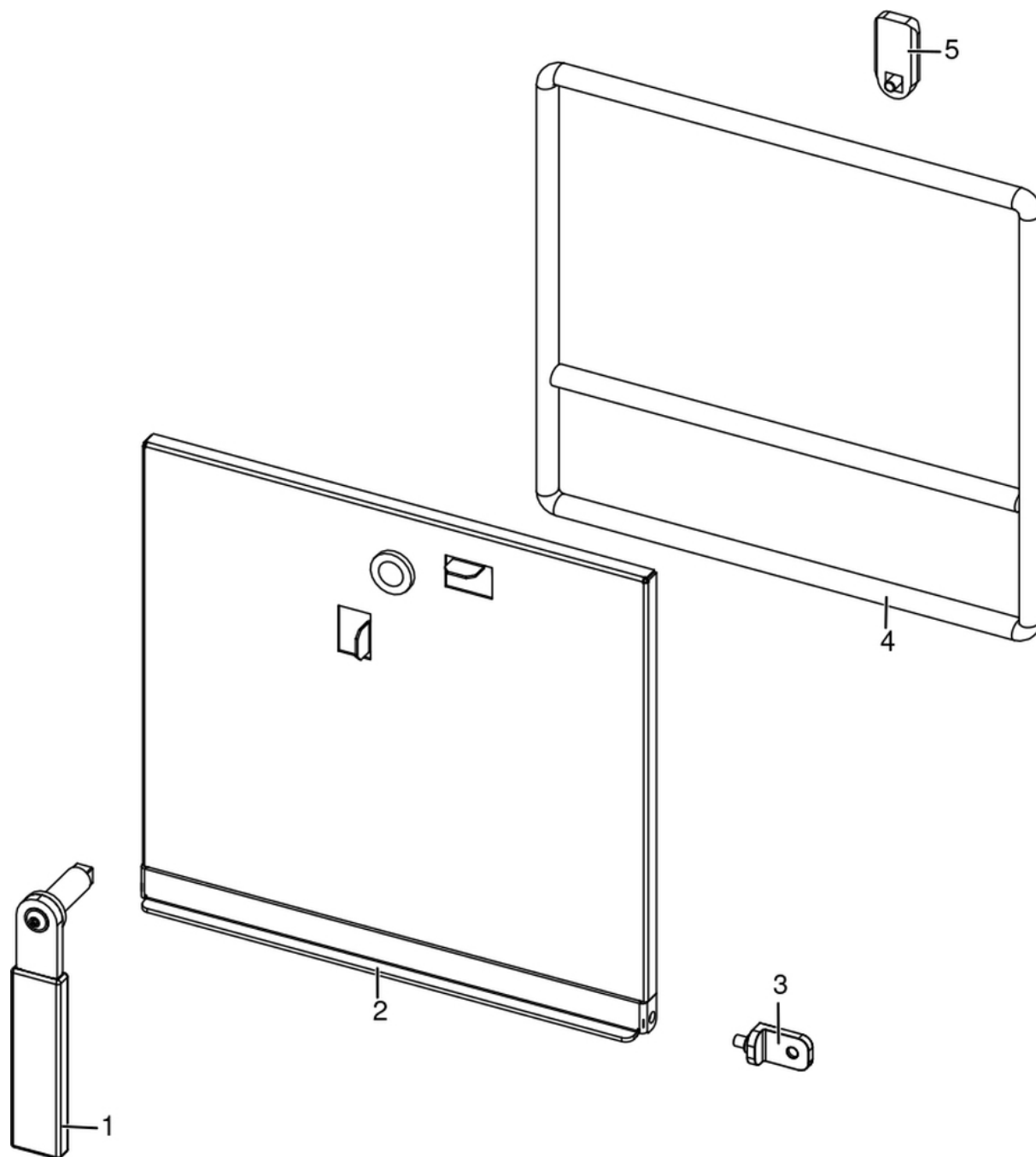

N°	Codice/Code	Descrizioni / Description / Beschreibung / Description / Description
1	41411621600	Maniglia con impugnatura porta cenere / Handle / Griff / Poignée / Tirador
2	41421605640V	Porta cenere / Ash drawer door / Tür des Aschenkastens / Porte tiroir à cendres / Puerta cajón ceniza
3	41411623740V	Cerniera acciaio porta cenere / Ash compartment door steel hinge / Aschenklappe Stahlscharnier / Chamier en acier porte compartiment cendre / Bisagra en acero puerta compartimento cenizas
4	412007003A	Cordino fibroceramico Ø 14 mm (5 mt.) / Ceramic fibre cord Ø 14 mm (5 m.) / Keramikfaserschnur Ø 14 mm (5 m) / Cordon en fibre céramique Ø 14 mm (5 m) / Junta a cuerda de fibra cerámica Ø 14 mm (5 m)
4	412007003B	Cordino fibroceramico Ø 14 mm (50 mt.) / Ceramic fibre cord Ø 14 mm (50 m.) / Keramikfaserschnur Ø 14 mm (50 m) / Cordon en fibre céramique Ø 14 mm (50 m) / Junta a cuerda de fibra cerámica Ø 14 mm (50 m)
4	412007003C	Kit sostituzione cordino (cordino+silicone) Ø 14 mm / Cord replacement kit (cord + silicon) Ø14 mm / Schnuraustauschset (Schnur +Silikon) Ø 14 mm / Kit remplacement cordon (cordon+silicon) Ø 14 / Kit sustitución junta a cuerda (junta a cuerda+silicón) Ø 14 mm

5	41201608400	Serratura porta cassetto cenere / Door lock for ash drawer / Türschloss für Aschenkasten / Serrure de porte du tiroir à cendres / Cerradura puerta cajón ceniza
---	-------------	-----------------------------------------------------------------------------------------------------------------------------------------------------------------

EGO HYDROMATIC 12 M1

Gruppo caricamento pellet acciaio / Pellet feed group in steel / Pellet Fördergruppe aus Stahl / Groupe de chargement pellet en acier / Grupo de carga pellet acero

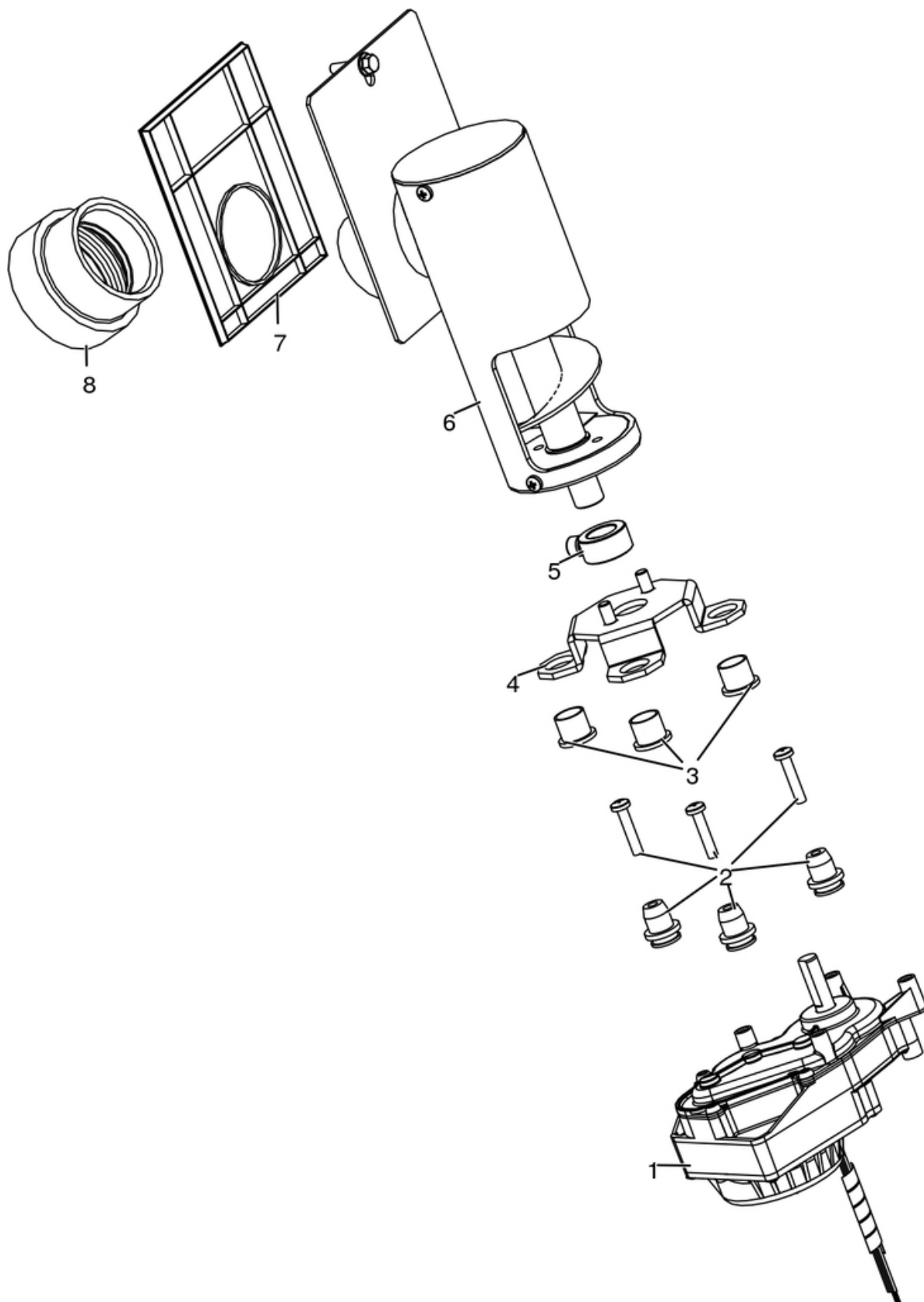

N°	Codice/Code	Descrizioni / Description / Beschreibung / Description / Descripción
1	41451702200	Motoriduttore brushless / Brushless reduction motor / Brushless Getriebemotor / Motoréducteur brushless / Motorreductor brushless
2	41801703700	Gommini antivibrante / Vibration damper rubber / Rammschutz Gummi / Caoutchouc antivibratoire / Cauchitos antivibración
3	41201800700	Boccola (3 pz) / Bushing (3 pcs) / Buchse (3 Stk) / Douille (3 pcs) / Abrazadera (3 pzs)
4	41411779331	Supporto coclea "Ragno" / Pellet feed screw bracket "spider" / "Spinne" Schenke Gestell / Support vis sans fin "Araignée" / Soporte coclea "Araña"
5	4120398	Connettore motoriduttore-coclea / Reduction motor-feed screw connector / Verbindung Getriebemotor-Schnecke / Connecteur motoréducteur-vis sans fin / Conector motorreductor-cóclea
6	41411800151	Gruppo alimentazione completo / Complete feed screw / Komplette Förderschnecke / Vis sans fin complète / Coclea de carga completa
7	41801600400	Guarnizione gruppo caricamento / Gasket / Dichtung / Joint / Junta
8	41801702600	Disaccoppiatore mesc. Marrone / Brown disengaging device / Braun Verängungsrohr / Tuyau de découplage maron / Tubo de desvío marron

EGO HYDROMATIC 12 M1

Gruppo elettrico ed elettronico / Electrical and electronic group / Elektrische und elektronische Gruppe / Groupe électrique et électronique / Grupo eléctrico y electrónico

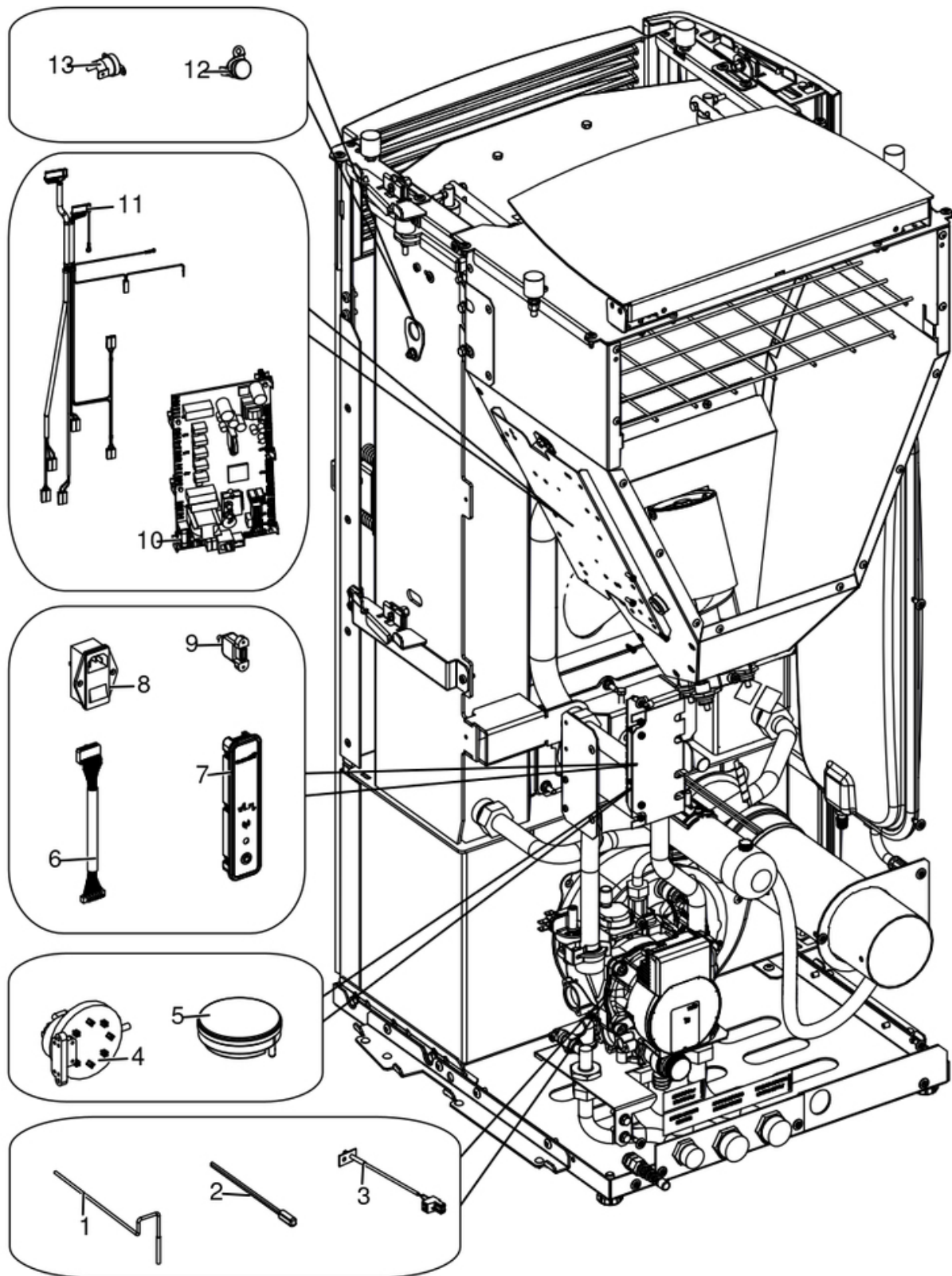

N°	Codice/Code	Descrizioni / Description / Beschreibung / Description / Descripcion
1	4012062	Sonda NTC a filo per acqua / Water temperature sensor / Wassertemperaturfühler / Sonde température eau / Sonda temperatura agua
2	4160240	Sonda temperatura ambiente / Room temperature sensor / Raumtemperaturfühler / Sonde température ambiance / Sonda temperatura aire
3	41451703600	Sonda fumi con flangia con morsettiera L.980 / Smoke sensor with flange with terminal board L.980 / Rauchsonde mit Flansche mit Klemmenbrett L.980 / Sonde fumées avec bride avec serre-câble L.980 / Sonda humos con brida con borne L.980
4	4160482	Pressostato 0,4 mbar / Pressure gauge 0,4 mbar / Druckschalter 0,4 mbar / Pressostat 0,4 mbar / Presostato 0,4 mbar
5	41451303400	Trasduttore di pressione / Pressure transducer / Active-Wandler / Transducteur de pression / Transductor de pression
6	41451801600	Cavo flat 20 vie L.600 mm / Flat cable 20 pin L.600 mm / Flat-Kabel 20polig L.600 mm / Cable flat 20 voies L.600 mm / Flat cable 20 vias L.600 mm
7	41451602801	Pannello di emergenza Wireless / Wireless emergency display / Wireless Notfall-Blende / Panneau d'urgence wireless / Panel emergencia wireless
8	4160193	Pulsante accensione / On/Off button / Zündungstaste / Touche d'allumage / Botón encendido
9	41451403200	Cavo USB da pannello L.500 / USB Cable from display L.500 / USB Kabel von Notfalldisplay L.500 / Câble USB de panneau L.500 / Cable USB del panel L.500
10	41451904300	Scheda madre / Motherboard / Hauptplatine / Carte mère / Tarjeta madre
11	41451905700	Cablaggio / Wiring / Verkabelung / Câblage / Cableado
12	412007004	Clickson 110°C / Clickson 110°C / Clickson 110°C / Clickson 110°C / Clickson 110°C
13	41450901100	Clickson 95°C / Clickson 95°C / Clickson 95°C / Clickson 95°C / Clickson 95°C

EGO HYDROMATIC 12 M1

Gruppo fumi / Smoke group / Rauchgruppe / Groupe fumées / Grupo de humos

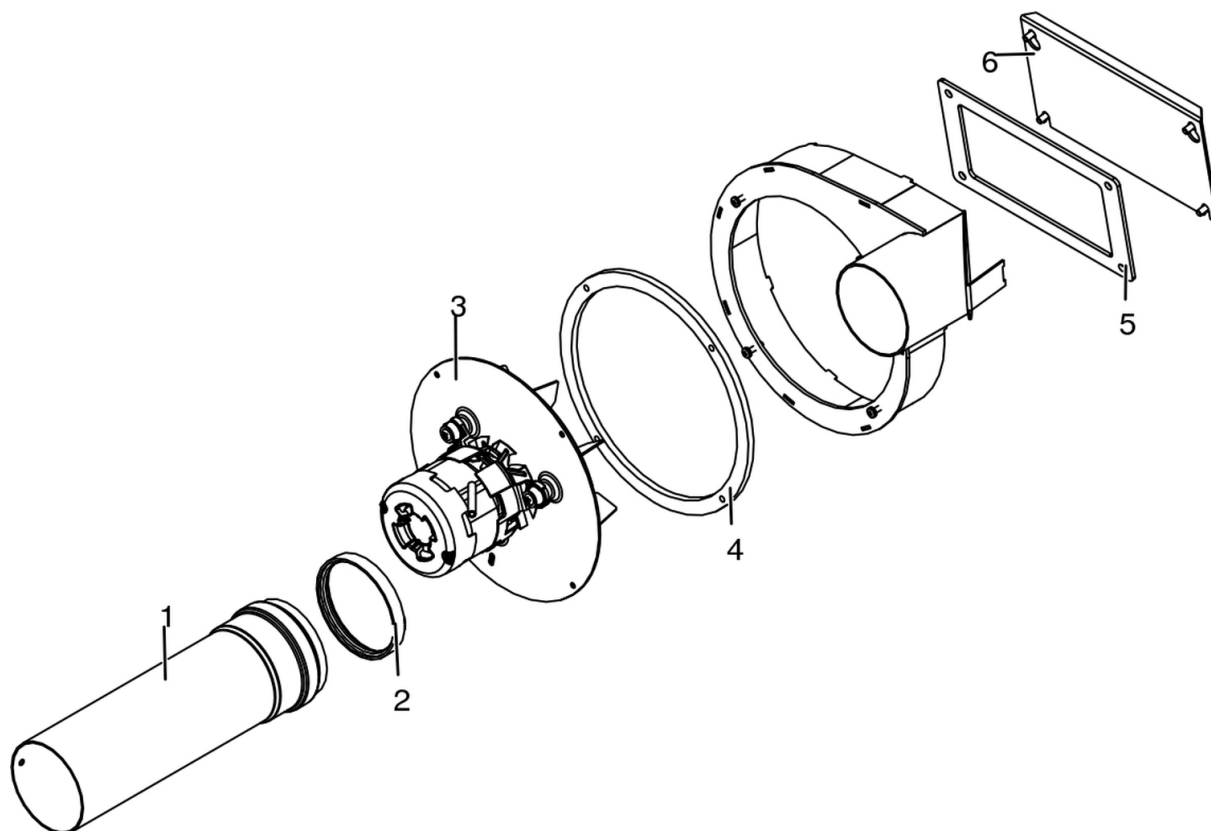

N°	Codice/Code	Descrizioni / Description / Beschreibung / Description / Descripción
1	41601601160	Tubp fumi a innesto Ø80 con guarnizione / Smoke pipe Ø 80 with gasket / Rauchrohr Ø 80 mit Dichtung / Tuyau fumées Ø 80 avec joint / Tubo humos Ø 80 con junta
2	40120969	Guarnizione silicone (5pz) / Silicone Gasket (5pc.) / Silikondichtung (5 St.) / Joint en silicone / Junta en silicona
3	41451600100	Ventilatore fumi senza chiocciola stagno / Air-tight smoke exhausted fan / Luftdicht Rauchgasgebläse / Ventilateur fumées étanche / Ventilador humos hermético
3	41452009200	Encoder ventilatore / Fan encoder / Lüfter Encoder / Encodeur de ventilateur / Codificador de ventilador
4	41801301500	Guarnizione ventilatore fumi / Smoke exhaust fan gasket / Dichtung Rauchabsauggebläse / Joint Ventilateur aspiration fumées / Junta ventilador aspiración humos
5	41801601300	Guarnizione tappo camera fumi / Smoke compartment plug gasket / Dichtung Rauchabzugklappe / Joint clapet compartiment fumées / Junta tapón compartimento humos
6	41401605530	Tappo camera fumi zincato / Smoke compartment galvanized plug / Verzinktes Rauchabzugklappe / Join zingué compartiment fumées / Tapón galvanizado compartimento humos

EGO HYDROMATIC 12 M1

Gruppo caricamento pellet alluminio / Pellet feed group aluminium / Pellet Fördergruppe Aluminium /
Groupe de chargement pellet aluminium / Grupo de carga pellet aluminio

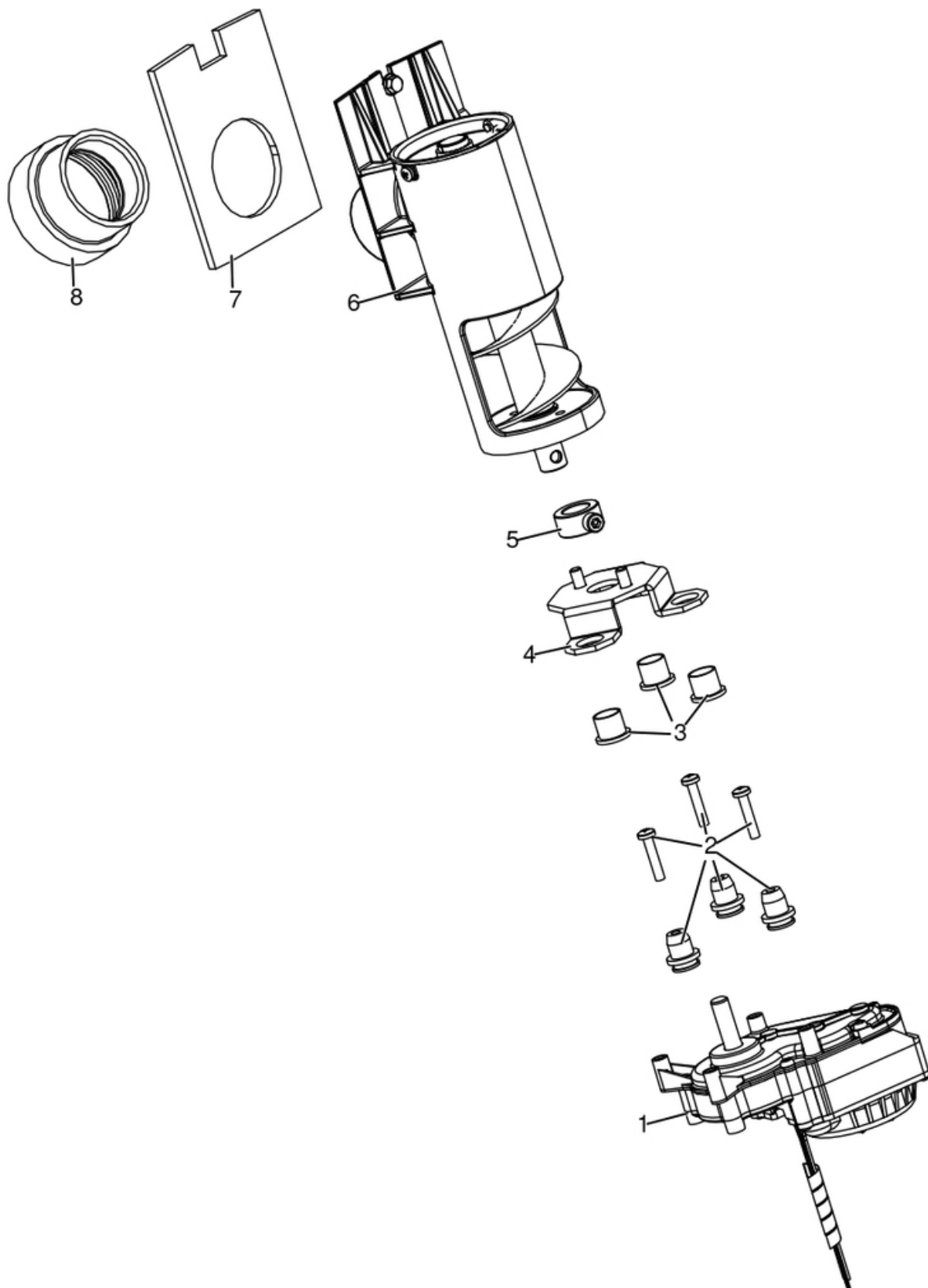

N°	Codice/Code	Descrizioni / Description / Beschreibung / Description / Descripción
1	41451702200	Motoriduttore brushless / Brushless reduction motor / Brushless Getriebemotor / Motoréducteur brushless / Motorreductor brushless
2	41801703700	Gommini antivibrante / Vibration damper rubber / Rammschutz Gummi / Caoutchouc antivibratoire / Cauchitos antivibración
3	41201800700	Boccola (3 pz) / Bushing (3 pcs) / Buchse (3 Stk) / Douille (3 pcs) / Abrazadera (3 pzs)
4	41411779331	Supporto coclea "Ragno" / Pellet feed screw bracket "spider" / "Spinne" Schenke Gestell / Support vis sans fin "Araignée" / Soporte coclea "Araña"
5	4120398	Connettore motoriduttore-coclea / Reduction motor-feed screw connector / Verbindung Getriebemotor-Schnecke / Connecteur motoréducteur-vis sans fin / Conector motorreductor-cóclea
6	41402002050	Gruppo alimentazione / Complete feed screw / Komplette Förderschnecke / Vis sans fin complète / Coclea de carga completa
7	41802000300	Guarnizione / Gasket / Dichtung / Joint / Junta
8	41801702600	Disaccoppiatore mesc. Marrone / Brown disengaging device / Braun Verängungsrohr / Tuyau de découplage maron / Tubo de desvío marron

EGO HYDROMATIC 12 M1

Gruppo accensione e aria comburente / Ignition and combustion air group / Entzündungs- und Verbrennungsluftgruppe / Groupe allumage et aire comburente / Grupo encendido y aire de combustion

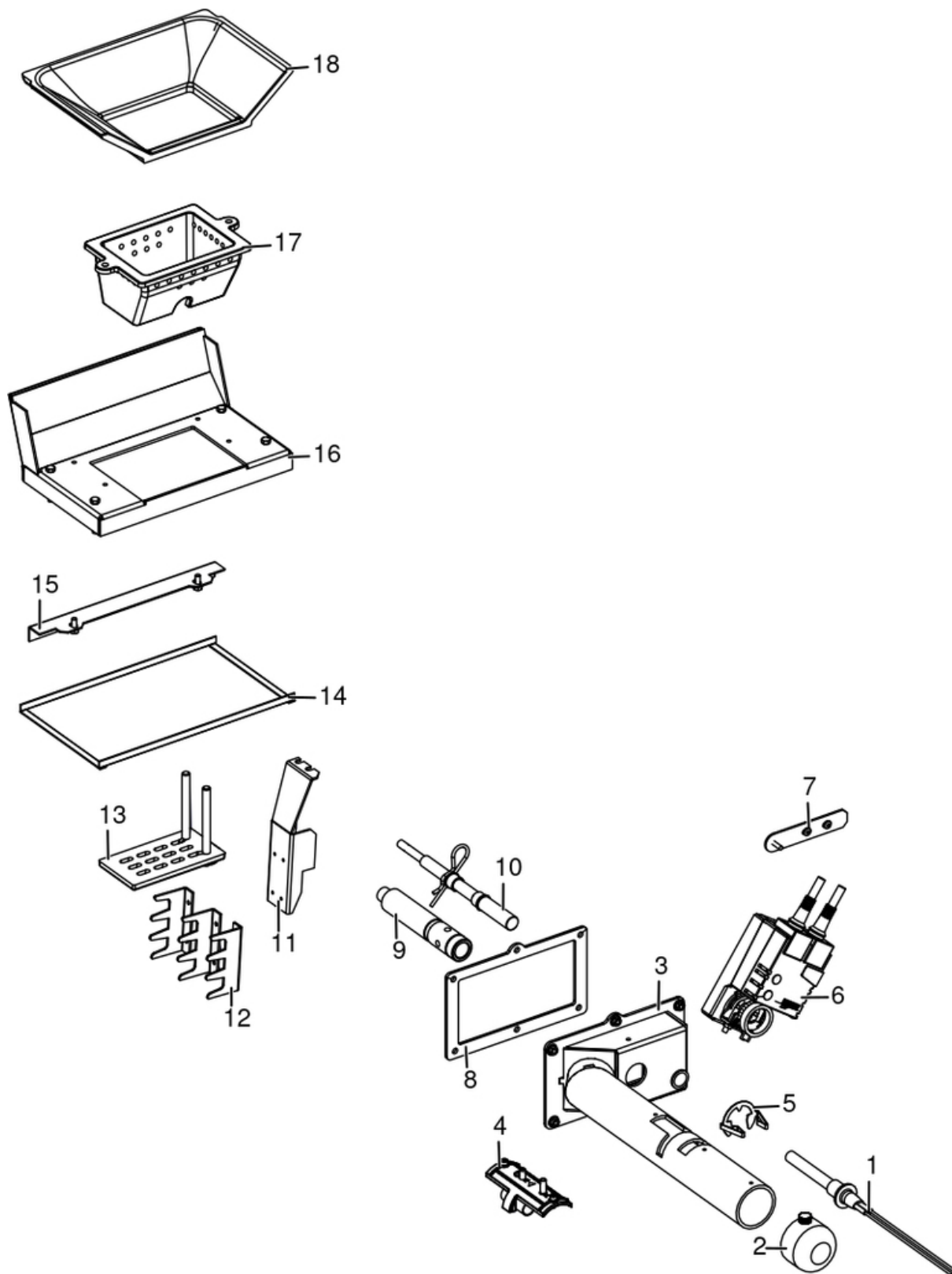

N°	Codice/Code	Descrizioni / Description / Beschreibung / Description / Description
----	-------------	----------------------------------------------------------------------

1	41451308101	Candeletta 315 Watt / Sparkplug 315 Watt / Zündkerze 315 Watt / Bougie 315 Watt / Bujía 315 Watt
1	41451308101FE	Candeletta (200 pz) / Sparkplug (200 pcs) / Zündkerze (200 St.) / Bougie (200 pcs) / Bujía
1	41451308150	Kit 25 candelette 315 Watt / 25 Sparkplugs 315 Watt kit / Bausatz 25 Zündkerzen 315 Watt / Kit 25 Bougies 315 Watt / Kit 25 Bujías 315 Watt
2	41401036100	Filtro antipolvere / Anti-dust filter / Staubschutzfilter / Filtre antipoussière / Filtro de protección polvo
3	41411609140V	Supporto sistema braciere autopulente / Self-cleaning grate support / Selbstreinigend Brennertopf Gestell / Support brasero autonettoyant / Soporte brasero en arrabio autolimpiador
4	41601305050	Componente rilevamento portata aria / Air flow measure component / Bauteil für Messung der Luftmenge / Composant pour la mesuration de la quantité d'air / Componente por la medida de l'aire
5	41201601500	Anello arresto candeletta / Sparkplug stop / Zündkerzestopper / Butée bougie / Tope bujía
6	41451600900	Attuatore rotativo / Actuator / Trieb / Actionneur / Actuador
7	41401620420	Staffa attuatore rotativo / Actuator support / Triebhalterung / Support actionneur / Soporte actuador
8	418008027	Guarnizione / Gasket / Dichtung / Joint / Junta
9	41601802700	Condotto candeletta / Sparkplug Conduit / Zündkerzenkanal / Conduit Bougie / Conducto Bujía
10	41201601300	Asse fondo braciere autopulente / Self-cleaning bottom grate shaft / Selbstreinigend Brennertopf Bolzen / Pivot brasero autonettoyant / Perno brasero autolimpiador
11	41401605630	Supporto spuntoni fondo braciere / Bottom fireplace scraper support / Halterung Brennertopf Kratzer / Support racleur fond foyer / Soporte raspador fondo hogar
12	41401605730	Spuntoni fondo braciere / Bottom fireplace scraper / Brennertopf Kratzer / Racleur fond foyer / Raspador fondo hogar
13	41301601000V	Fondo braciere ghisa autopulente / Self-cleaning cast iron grate bottom / Selbstreinigend Brennertopf aus Gusseisen Boden / Fond brasero en fonte autonettoyant / Fondo brasero en arrabio autolimpiador
14	4120573A	Guarnizione a nastro 8 mm (5 mt.) per porta / Door strip gasket 8 mm (5 m) / Türbanddichtung 8 mm (5 m) / Joint ruban 8 mm (5 m) pour porte / Guarnición de cinta para puerta 8 mm (5 m)
14	4120573B	Guarnizione a nastro 8 mm (50 mt.) per porta / Door strip gasket 8 mm (50 m) / Türbanddichtung 8 mm (50 m) / Joint ruban 8 mm (50 m) pour porte / Guarnición de cinta para puerta 8 mm (50 m)
15	41401611030	Deflettore aria vetro / Door deflector / Leitblech der Tür / Déflecteur de la porte / Deflector de la puerta
16	41411609440V	Convogliatore aria vetro / Air duct / Luftförderer / Convoyeur d'air / Canalizador aire
17	41301601100V	Braciere ghisa autopulente / Self-cleaning cast iron grate / Selbstreinigend Brennertopf aus Gusseisen / Brasero en fonte autonettoyant / Brasero en arrabio autolimpiador
18	41301601200V	Scivolo braciere ghisa autopulente / Self-cleaning grate amp / Selbstreinigend Brennertopf Rutsche / Glissière brasero autonettoyant / Tobogán brasero autolimpiador

EGO HYDROMATIC 12 M1

Gruppo componenti idraulici / Hydraulic components group / Hydraulische Komponenten / Groupe de composants hydrauliques / Grupo de componentes hidráulicos

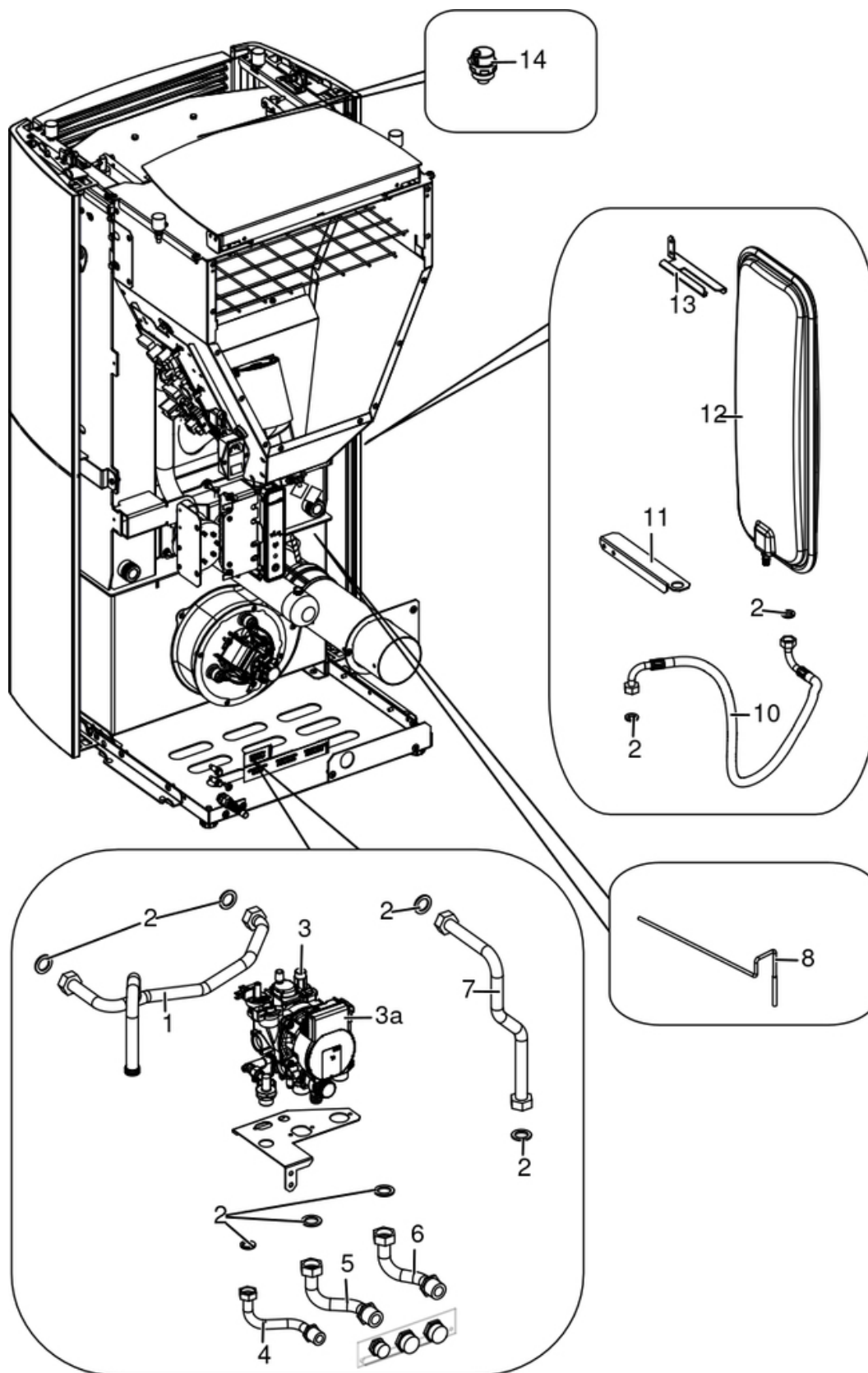

N°	Codice/Code	Descrizioni / Description / Beschreibung / Description / Descripción
1	41501700500	Tubo circolazione caldaia / Boiler circulation tube / Rohr für Kesselumwälzung / Tuyau de circulation chaudière / Tubo de circulación caldera
2	41207910	Kit guarnizioni impianto idraulico / Hydraulic system gasket kit / Dichtungsbausatz für Hydraulikanlage / Kit de joints pour l'installation hydraulique / Kit de juntas de la instalación de fontanería
3	41501600251	Kit idraulico pompa Wilo Para alta efficienza / Hydraulic kit high efficiency pump Wilo Para / Hydraulische Baugruppe hoch Effizienz Pumpe Wilo Para / Kit hydraulique pompe de circulation Wilo Para haut rendement / Kit fontanero bomba circulación Wilo Para alto rendimiento
3a	41502002100	Circolatore Wilo Para 7 IPWM / Water circulation pump Wilo Para 7 IPWM / Umwälzpumpe Wilo Para 7 IPWM / Pompe de circulation Wilo Para 7 IPWM / Bomba de circulación agua Wilo Para 7 IPWM
3a	41502000200	Valvola by pass / By pass valva / Ventile By Pass / Soupape By Pass / Valvula by pass
3a	41501103300	Valvola di sicurezza 3 Bar / Maximum pressure valve 3 Bar / Sicherheitsventil 3 Bar / Soupape de pression maximale 3 Bar / Válvula máxima presión 3 Bar
3a	41451108000	Pressostato di minima H2O / Pressur switch H2O / Druckwächter H2O / Pressostat H2O / Presostato H2O
4	41501600400	Tubo di carico caldaia / Boiler loading tube / Rohr für Kesseleinfüllung / Tuyau de chargement chaudière / Tubo de carga caldera
5	41501600500	Tubo ritorno impianto / Return tube / Rücklaufrohr / Tuyau retour / Tubo de regreso
6	41501600700	Raccordo mandata impianto / Delivery tube connection / Vorlaufrohr Verbindung / Raccord tuyau refoulement / Raccor tubo de envío
7	41501600600	Tubo mandata impianto / Delivery tube / Vorlaufrohr / Tuyau refoulement / Tubo de envío
8	4012062	Sonda NTC a filo per acqua / Water temperature sensor / Wassertemperaturfühler / Sonde température eau / Sonda temperatura agua
10	41501601000	Tubo flessibile L.600 / Flexible tube L.600 / Flexibles Rohr L.600 / Tuyau flexible L.600 / Tubo flexible L.600
11	41401606930	Supporto vaso espansione / Expansion vessel support / Halterung Expansionsgefäß / Support vase d'expansion / Soporte vaso de expansión
12	4120775	Vaso espansione (6 l) / Expansion vessel (6 l) / Expansionsgefäß (6 l) / Vase d'expansion (6 l) / Vaso de expansión (6 l)
13	41401607030	Staffa vaso espansione / Expansion vessel bracket / Haltebügel Expansionsgefäß / Étrier vase d'expansion / Abrazadera vaso de expansión
14	4120779	Valvola di sfiato / Vent valve / Entlüftungsventil / Soupape de dégagement / Válvula respiradero

EGO HYDROMATIC 12 M1

Gruppo scambiatore / Exchanger group / Austausch Baugruppe / Groupe échangeur / Grupo intercambiador

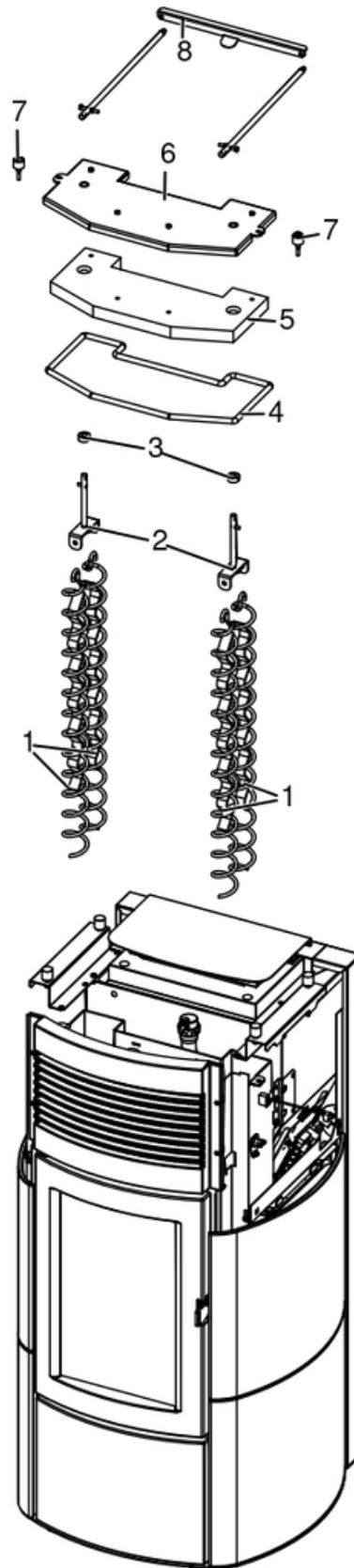

N°	Codice/Code	Descrizioni / Description / Beschreibung / Description / Descripción
1	41400914540	Eliche raschiatore (1 pz.) / Turbulator props (1 pc.) / Propeller des Schabers (1 Teil) / Hélices turbulateur (1 pz.) / Hélice rascador (1 pz.)
2	41401129341	Staffa sostegno raschiatore Inox / Inox turbulator support bar / Haltebügel des Schabers aus Inox / Etrier support turbulateur en Inox / Zuncho apoyo rascador de Inox
3	41200903300	Trascinatore turbolatori (2 pz.) / Turbolator props puller (2 PC.) / Reinigungsspiralenmitnehmer (2 STCK). / Meneur de turbolateur (2 Pc.) / Arrebatador hélice rascador (2 pz.)
4	41801603200A	Treccia Ø10(5mt) / Braid Ø10(5mt) / Zopf Ø10(5mt) / Tresse Ø10(5mt) / Trenza Ø10(5mt)
5	41151600100	Pannello vermiculite coperchio / Vermiculite cover / Deckel aus Vermiculite / Couvercle en vermiculite / Tapa en vermiculite
6	41411608940V	Coperchio struttura caldaia nero / Boiler black cover / Schwarz Kelleldeckel / Couvercle noir chaudière / Tapa negra caldera
7	41801499550	Kit scarico sovrappressione camera di combustione (pz.2) / Pressure relief kit (Pcs.2) / Bausatz überdruckablauf brennkammer (Stck.2) / Kit decompression chambre combustion (Pcs.2) / Kit descompresion camara combustion (Pcs.2)
8	41401605430	Traversa leve movimentazione turbolatori / Tturbolator handling crossbeam / Turbolatorstange Träger / Traverse tige turbolateur / Traversa asta rascador