

THEA HYDRO 23 S1

Gruppo estetico / Aesthetic group / Aesthetische Gruppe / Groupe esthétique / Grupo estético

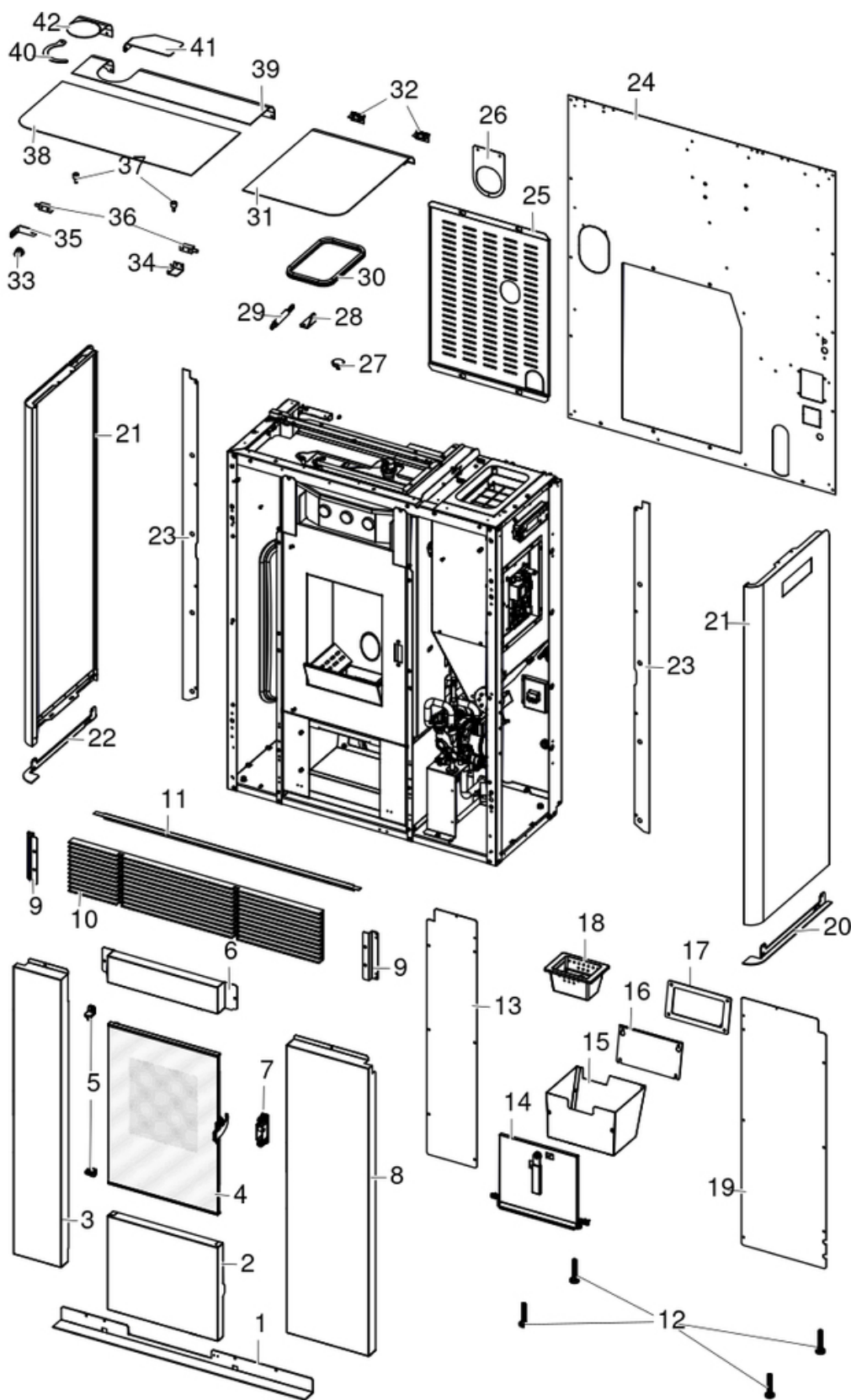

N°	Codice/Code	Descrizioni / Description / Beschreibung / Description / Descripcion
1	4140206173000	Profilo anteriore inferiore / Lower fastening bracket profile / Vordere Haltebügel für Scheibebefestigung Profil / Profil antérieur patte de fixation / Perfil anterior fermacristal
2	41402064950	Pannello frontale inferiore / Lower front panel / Komplette unteres vorderes Panel / Panneau antérieur inférieur complet / Panel frontal inferior completo
3	4140206394000	Pannello frontale sinistro / Left front panel / Linke Vordere Panel / Panneau avant gauche / Panel frontal izquierdo
4	437020086	Gruppo porta focolare / Fireplace door / Feuerstelle Tür / Porte foyer / Puerta hogar
5	412008063	Cerniere porta fuoco (2 pz) / Fire door hinge (2pcs) / Scharnier Feuertür (2 Stck) / Charnière porte foyer (2 pcs) / bisagra puerta del hogar (2 pz)
6	4140206384000	Pannello frontale superiore / Upper front panel / Vordere obere Panel / Panneau antérieur supérieur / Panel frontal superior

THEA HYDRO 23 S1

Porta fuoco / Fire door / Feuertür / Porte foyer / Puerta hogar

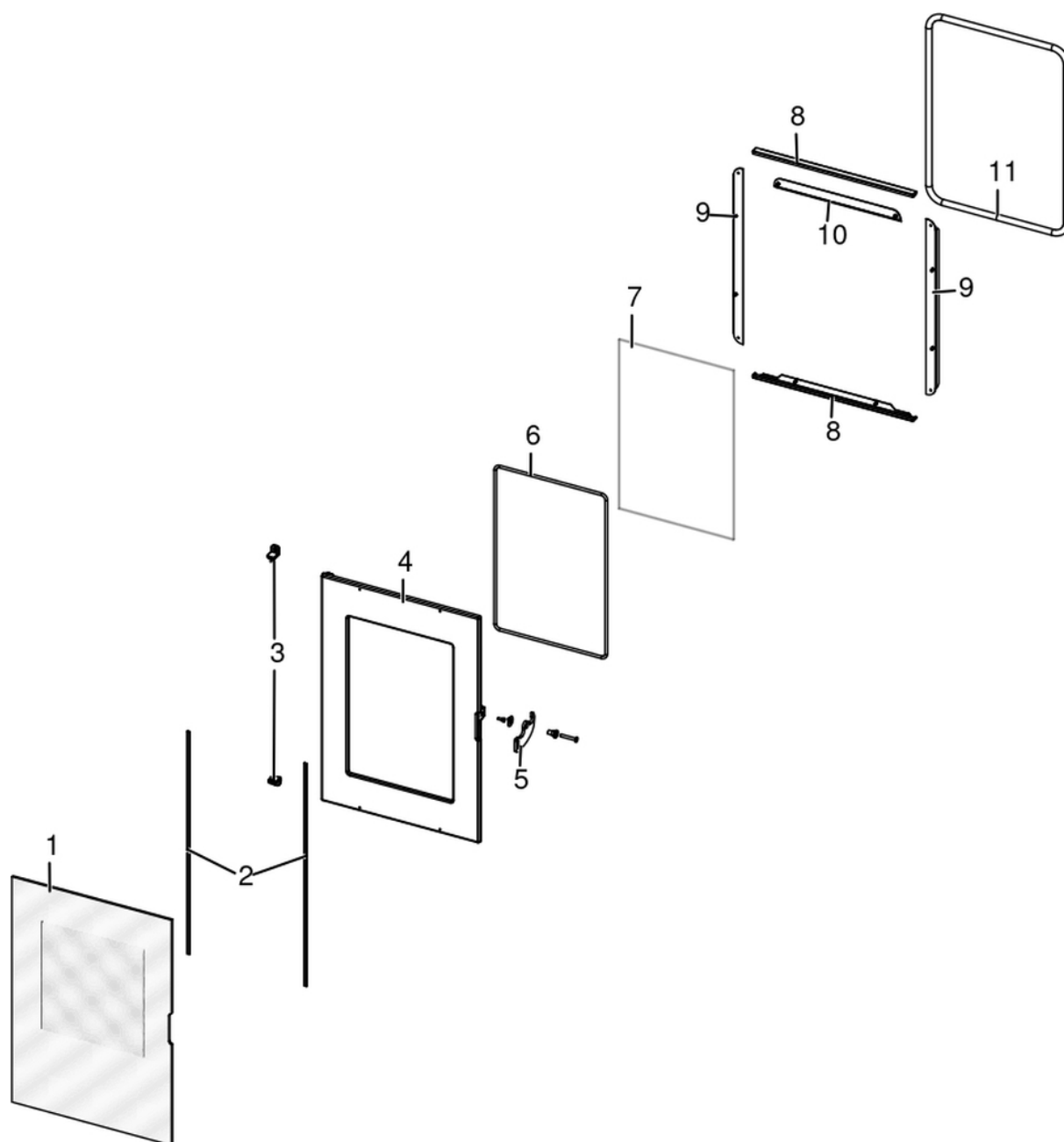

N°	Codice/Code	Descrizioni / Description / Beschreibung / Description / Descripción
1	41702002191	Vetroceramico serigrafato / Screen printed glass / Siebdruckglaskeramikscheibe / Vitrocéramique avec sérigraphie / Vidrio cerámico con serigrafía
2	4120572A	Guarnizione a nastro 6 mm (5 mt.) per porta / Door strip gasket 6 mm (5 m) / Türbanddichtung 6 mm (5 m) / Joint ruban 6 mm (5 m) pour porte / Guarnición de cinta para puerta 6 mm (5 m)
2	4120572B	Guarnizione a nastro 6 mm (50 mt.) per porta / Door strip gasket 6 mm (50 m) / Türbanddichtung 6 mm (50 m) / Joint ruban 6 mm (50 m) pour porte / Guarnición de cinta para puerta 6 mm (50 m)
3	412008063	Cerniere porta fuoco (2 pz) / Fire door hinge (2pcs) / Scharnier Feuertür (2 Stck) / Charnière porte foyer (2 pcs) / bisagra puerta del hogar (2 pz)
4	4130200522000	Porta ghisa focolare / Cast iron hearth door / Feurraumtür aus Gusseisen / Porte foyer en fonte / Puerta hogar de arrabio
5	41402061290	Maniglia porta / Door Handle / Türgriff / Poignée porte / Tirador
6	41801603300A	Guarnizione Ø5 5mt / Gasket Ø5 5mt / Dichtung Ø5 5mt / Joint Ø5 5mt / Junta Ø5 5mt

6	41801603300B	Guarnizione Ø5 50mt / Gasket Ø5 50mt / Dichtung Ø5 50mt / Joint Ø5 50mt / Junta Ø5 50mt
6	41801603300C	Guarnizione Ø5 5mt + silicone / Gasket Ø5 5mt + silic / Dichtung Ø5 5mt + Silikon / Joint Ø5 5mt + silic / Junta Ø5 5mt
7	41702001800	Vetroceramico porta / Ceramic-glass door / Glaskeramik-Tür / Vitrocéramique porte / Cristal cerámico puerta
8	4140206133000	Profilo fermavetro / Fastening bracket profile / Haltebügel für Scheibebefestigung Profil / Profil patte de fixation / Perfil fermacristal
9	4140203823000	Fermavetro porta focolare / Firebox door glazing bead / Haltebügel für Scheibebefestigung Tür / Perle de vitrage de porte de foyer / Retenedor del cristal - Puerta
10	4140203833000	Deflettore porta focolare / Firebox door deflector / Feuerraumtür Leitblech / Déflecteur porte foyer / Deflector puerta hogar
11	4120104A	Cordino fibroceramico Ø 12 mm (5 mt.) / Ceramic fibre cord Ø 12 mm (5 m.) / Keramikfaserschnur Ø 12 mm (5 m) / Cordon en fibre céramique Ø 12 mm (5 m) / Junta a cuerda de fibra cerámica Ø 12 mm (5 m)
11	4120104B	Cordino fibroceramico Ø 12 mm (50 mt.) / Ceramic fibre cord Ø 12 mm (50 m.) / Keramikfaserschnur Ø 12 mm (50 m) / Cordon en fibre céramique Ø 12 mm (50 m) / Junta a cuerda de fibra cerámica Ø 10 mm (52 m)

THEA HYDRO 23 S1

Porta cenere / Ash door / Ashentür / Porte cendre / Puerta ceniza

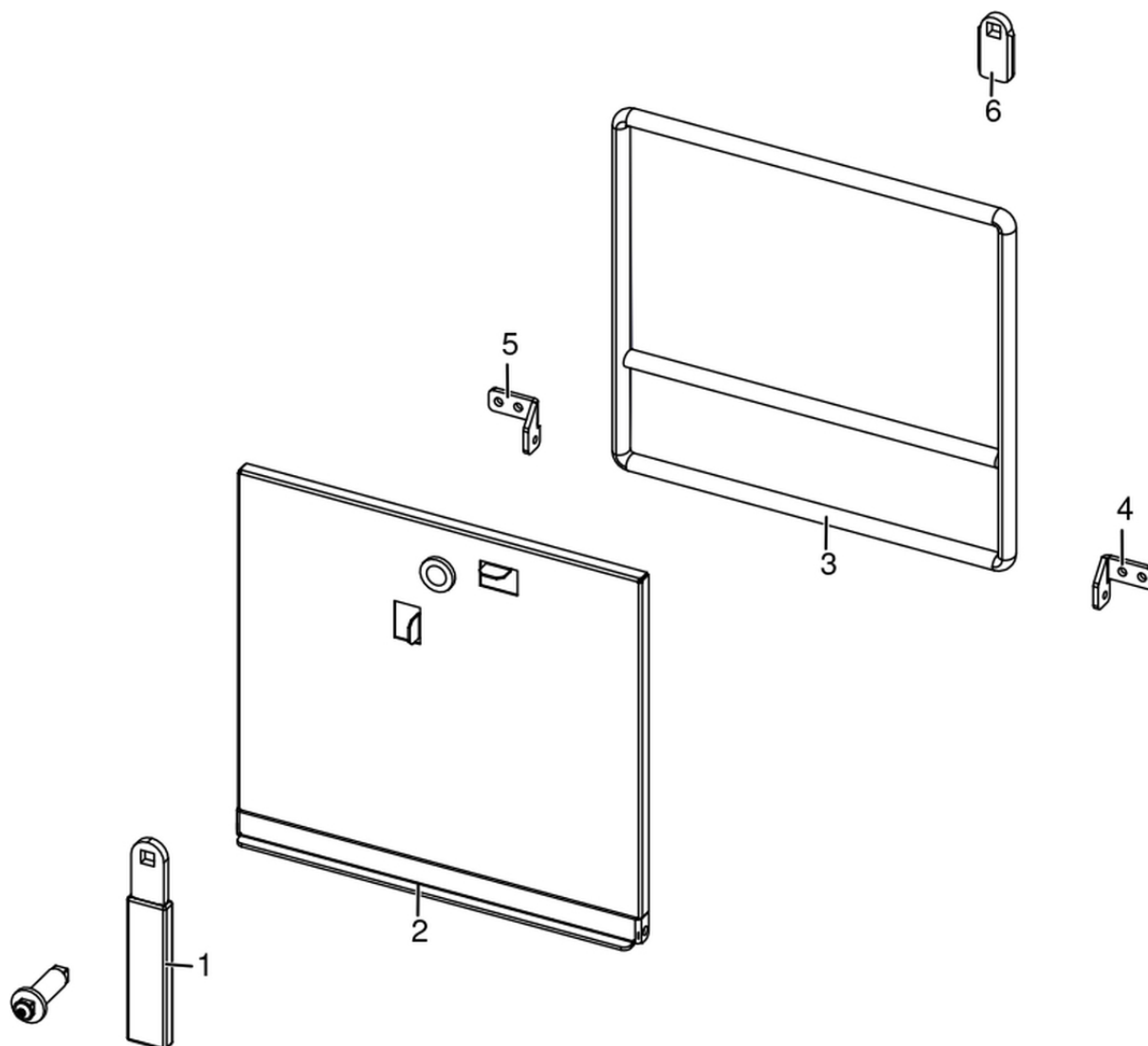

N°	Codice/Code	Descrizioni / Description / Beschreibung / Description / Descripción
1	41411621600	Maniglia con impugnatura porta cenere / Handle / Griff / Poignée / Tirador
2	41421605640V	Porta cenere / Ash drawer door / Tür des Aschenkastens / Porte tiroir à cendres / Puerta cajón ceniza
3	412007003A	Cordino fibroceramico Ø 14 mm (5 mt.) / Ceramic fibre cord Ø 14 mm (5 m.) / Keramikfaserschnur Ø 14 mm (5 m) / Cordon en fibre céramique Ø 14 mm (5 m) / Junta a cuerda de fibra cerámica Ø 14 mm (5 m)
3	412007003B	Cordino fibroceramico Ø 14 mm (50 mt.) / Ceramic fibre cord Ø 14 mm (50 m.) / Keramikfaserschnur Ø 14 mm (50 m) / Cordon en fibre céramique Ø 14 mm (50 m) / Junta a cuerda de fibra cerámica Ø 14 mm (50 m)
4	4141162393000	Cerniera destra / Right hinge / Rechtes Scharnier / Charnière droite / Bisagra derecha
5	4141162403000	Cerniera sinistra / Left hinge / Linkes Scharnier / Charnière gauche / Bisagra izquierda
6	41201608400	Serratura porta cassetto cenere / Door lock for ash drawer / Türschloss für Aschenkasten / Serrure de porte du tiroir à cendres / Cerradura puerta cajón ceniza

THEA HYDRO 23 S1

Gruppo caricamento pellet / Pellet feed group / Pellet Fördergruppe / Groupe chargement du pellet / Grupo de carga pellet

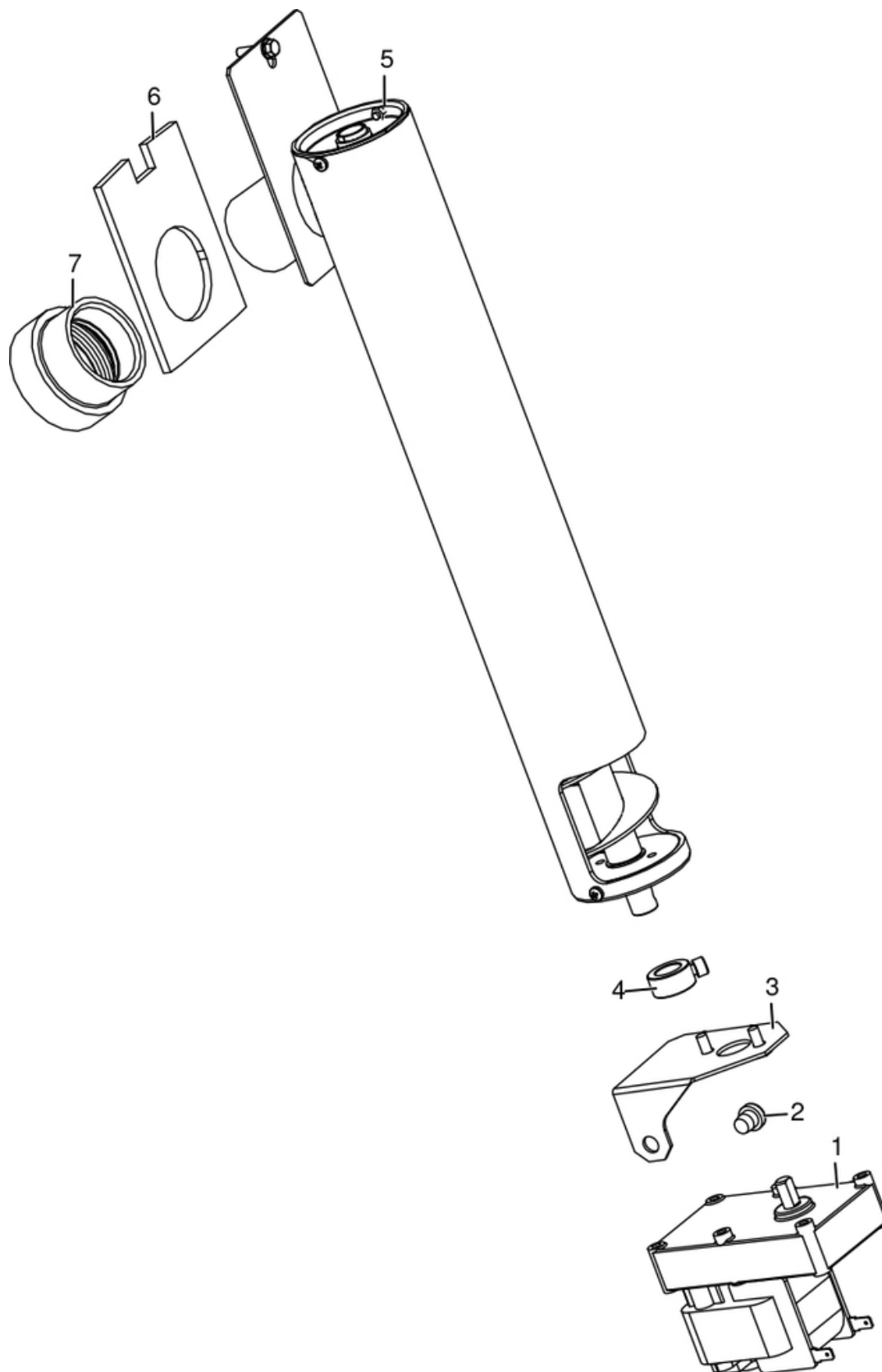

N°	Codice/Code	Descrizioni / Description / Beschreibung / Description / Descripcion
1	41450901600	Motoriduttore 3,3 rpm Merkle Korff / Reduction motor 3,3 rpm Merkle Korff / Getriebemotor 3,3 RPM MERKLE KORFF / Motoréducteur 3,3 RPM MERKLE KORFF / Motorreductor 3,3 rpm Merkle Korff
2	4120180	Gommini paracolpi (4 pz) / Rubber bumpers (4 pcs.) / Schlagschutzgummi (4 Stck) / Pièces caoutchouc antichoc (4 pcs) / Cauchitos anti-golpes (4 pz)
3	41402061130	Base coclea / Feed screw base / Untergestell der Förderschnecke / Base de la vis sans fin / Base de la còclea
4	4120398	Connettore motoriduttore-coclea / Reduction motor-feed screw connector / Verbindung Getriebemotor-Schnecke / Connecteur motoréducteur-vis sans fin / Conector motorreductor-còclea
5	41411881150	Assieme coclea / Auger set / Schneckebausatz / Groupe vis sans fin / Grupo vis sin fin
6	41801600400	Guarnizione gruppo caricamento / Gasket / Dichtung / Joint / Junta
6	41802000300	Guarnizione / Gasket / Dichtung / Joint / Junta
7	41801702600	Disaccoppiatore mesc. Marrone / Brown disengaging device / Braun Verängungsrohr / Tuyau de découplage maron / Tubo de desvio marron

THEA HYDRO 23 S1

Gruppo accensione e aria comburente / Ignition and combustion air group / Entzündungs- und Verbrennungsluftgruppe / Groupe allumage et aire comburente / Grupo encendido y aire de combustion

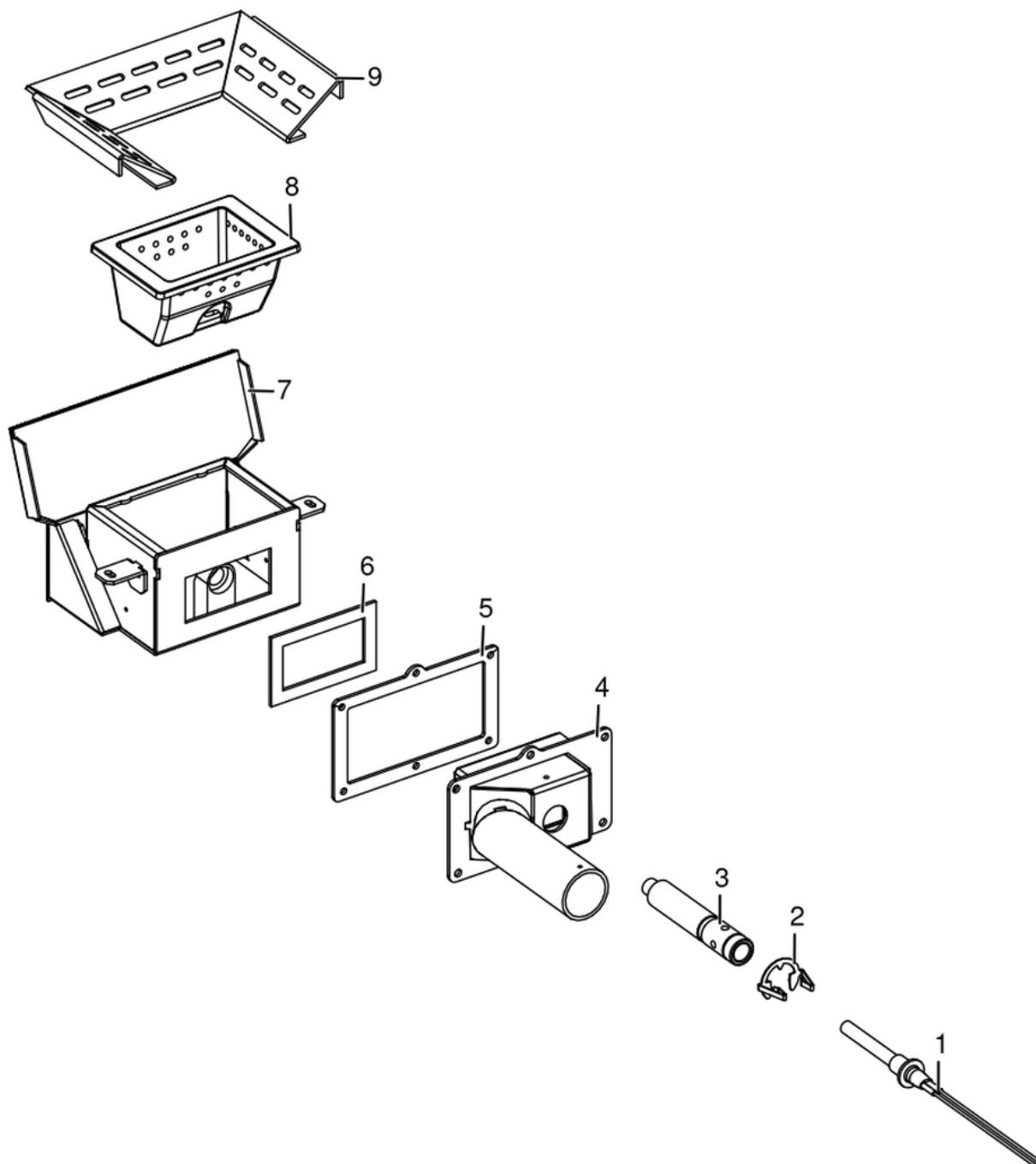

N°	Codice/Code	Descrizioni / Description / Beschreibung / Description / Descripción
1	41451308101	Candeletta 315 Watt / Sparkplug 315 Watt / Zündkerze 315 Watt / Bougie 315 Watt / Bujía 315 Watt
1	41451308150	Kit 25 candelette 315 Watt / 25 Sparkplugs 315 Watt kit / Bausatz 25 Zündkerzen 315 Watt / Kit 25 Bougies 315 Watt / Kit 25 Bujías 315 Watt
2	41201601500	Anello arresto candeletta / Sparkplug stop / Zündkerzestopper / Butée bougie / Tope bujía
3	41601802700	Condotto candeletta / Sparkplug Conduit / Zündkerzenkanal / Conduit Bougie / Conducto Bujía
4	4140206094000	Scatola aria comburente / Combustion air box / Verbrennungsluft Kasten / Boîte air de combustion / Caja aire de combustión
5	418008027	Guarnizione / Gasket / Dichtung / Joint / Junta

6	41801605800	Guarnizione tasca braciere / Combustion pot container gasket / Brenntopfkasten Dichtung / Joint récipient brasero / Burlete contenidor brasero
7	41411682441V	Tasca braciere / Combustion pot container / Brenntopfkasten / Récipient brasero / Contenedor brasero
8	41301602601V	Braciere ghisa / Cast iron brazier / Bernnschale aus Guß / Brasero en fonte / Brasero de arrabio
9	41411696230V	Scivolo braciere ghisa / Grate amp in cast iron / Brennertopf Rutsche aus Guß / Glissèrie brasero en fonte / Tobogán brasero en arrabio

THEA HYDRO 23 S1

Gruppo elettrico ed elettronico / Electrical and electronic group / Elektrische und elektronische Gruppe /
Groupe électrique et électronique / Grupo eléctrico y electrónico

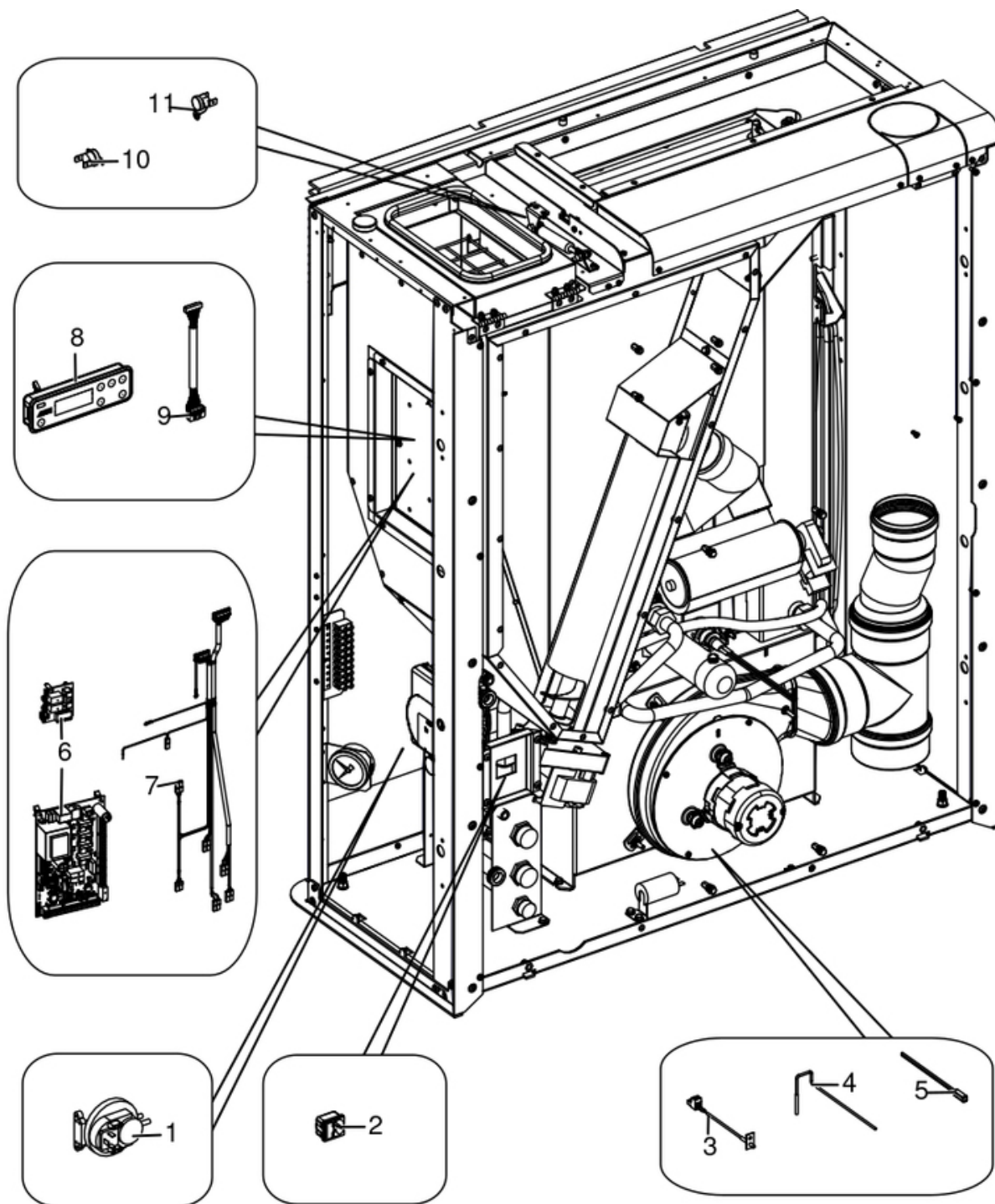

N°	Codice/Code	Descrizioni / Description / Beschreibung / Description / Descripción
1	4160482	Pressostato 0,4 mbar / Pressure gauge 0,4 mbar / Druckschalter 0,4 mbar / Pressostat 0,4 mbar / Presostato 0,4 mbar
2	41451104100	Presa con fusibile / Socket with fuse / Steckdose mit Sicherung / Prise avec fusible / Toma con fusible
3	41451002300	Sonda fumi con flangia / Smoke sensor with flange / Rauchgasfühler mit Flansche / Sonde fumées avec bride / Sonda humos con arandela
4	4012062	Sonda NTC a filo per acqua / Water temperature sensor / Wassertemperaturfühler / Sonde température eau / Sonda temperatura agua
5	4160240	Sonda temperatura ambiente / Room temperature sensor / Raumtemperaturfühler / Sonde température ambiante / Sonda temperatura aire
6	41452004400C	Scheda W003+PQ055_A01 - FW HYDRO 2018 / Motherboard W003+PQ055_A01 - FW HYDRO 2018 / Hauptplatine W003+PQ055_A01 - FW HYDRO 2018 / Carte mère W003+PQ055_A01 - FW HYDRO 2018 / Tarjeta madre W003+PQ055_A01 - FW HYDRO 2018
6	41452004400	Scheda madre W003+PQ055_A01 - non programmata / Unprogrammed motherboard W003+PQ055_A01 / Unprogrammierte Hauptplatine W003+PQ055_A01 / Carte mère W003+PQ055_A01 - Non programmée / Tarjeta madre W003+PQ055_A01 - sin programa
7	41452003100	Cablaggio elettrico / Electrical wiring / Elektrische Verkabelung / Câblage électrique / Cableado eléctrico
7	41451803550	Kit cablaggi messa a terra / Grounding wiring kit / Erdungskabelbaum / Kit mise à terre / Kit cableado a tierra
8	41451701500	Pannello comandi / Control panel / Bedienblende / Tableau de commandes / Panel de mandos
9	41451201900	Cavo Flat L 1,4 M / Flat cable L 1,4 M / Flat Kable L 1,4 M / Câble Flat L 1,4 M / Cable Flat L 1,4 M
10	41450901100	Clickson 95°C / Clickson 95°C / Clickson 95°C / Clickson 95°C / Clickson 95°C
11	412007004	Clickson 110°C / Clickson 110°C / Clickson 110°C / Clickson 110°C / Clickson 110°C

THEA HYDRO 23 S1

Gruppo fumi / Smoke group / Rauchgruppe / Groupe fumées / Grupo de humos

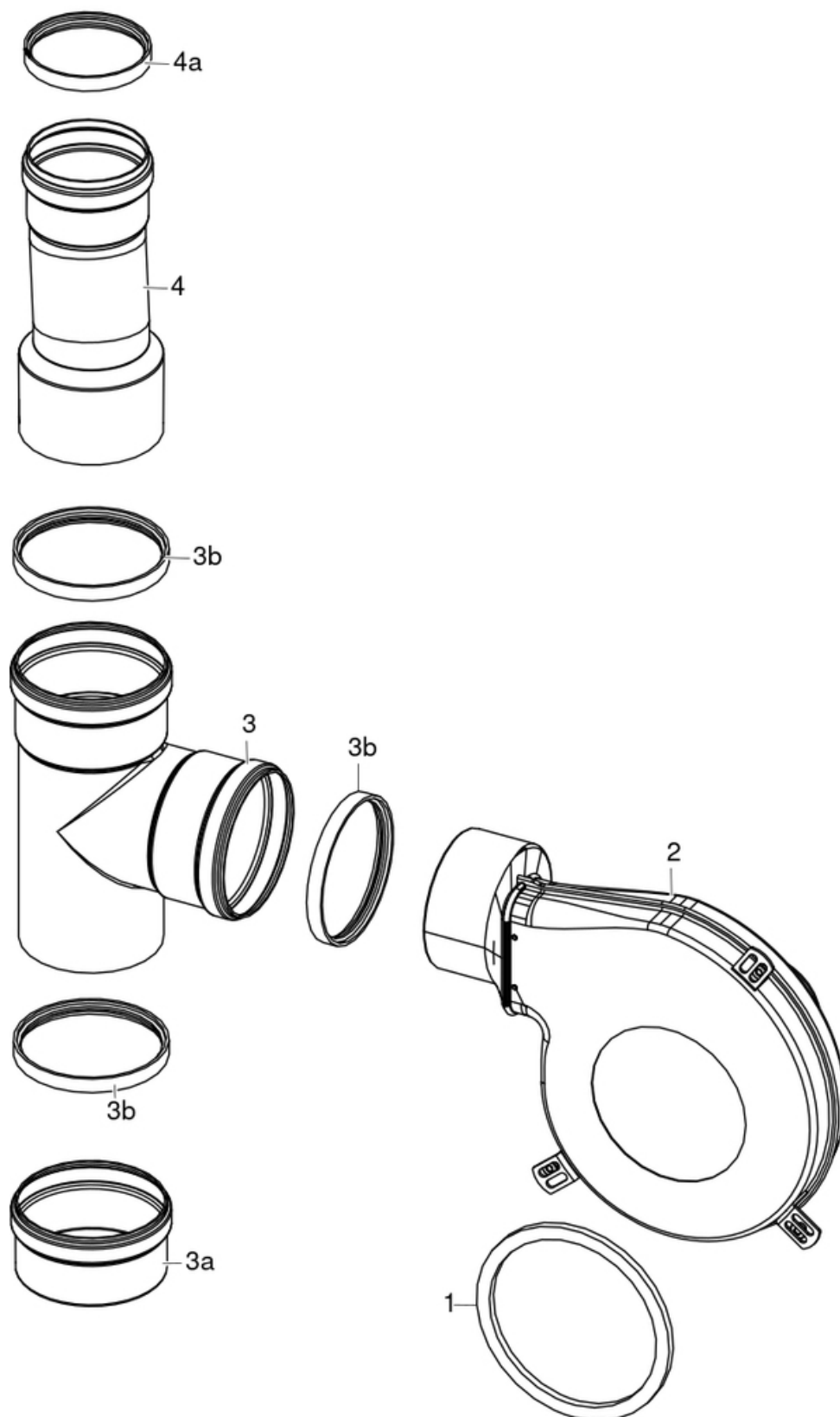

N°	Codice/Code	Descrizioni / Description / Beschreibung / Description / Descripción
1	41801100100	Guarnizione adesiva voluta fumi / Adhesive gasket smoke volute / Haftendichtung Rauchvolute / Joint adhesive volute fumées / Junta adhesiva voluta humos
2	41402036550	Estrattore fumi / Smoke exhaust fan / Rauchabsauggebläse / Ventilateur aspiration fumées / Ventilador aspiración de humos
3	41402036650	Raccordo "T" femmina - femmina Ø100 / T connection female - female Ø100 / T-Anschlussstück mit Muffe/Muffe Ø100 / Raccord T femelle - femelle Ø100 / Conector T hembra - hembra Ø100
3a	4160200180000	Tappo raccordo a "T" Ø 100 / Plug T connection Ø 100 / Verchluss T Verbindung Ø 100 / Clapé raccord en T Ø 100 / Tapón raccord T Ø 100
3b	40A12022	Guarnizione Ø 100 - 5 Pz / Gasket Ø 100 - 5 Pcs / Dichtung Ø 100 - 5 Stck / Joint Ø 100 - 5 Pcs / Junta Ø 100 - 5 Pzs
4	41602003300	Riduzione tubo fumi 100M-80F / Reduction of smoke pipe 100M-80F / Reduzierung der Rauchleitung 100M-80F / Réduction du tuyau de fumée 100M-80F / Reducción de tubo de humo 100M-80F
4a	40120969	Guarnizione silicone (5pz) / Silicone Gasket (5pc.) / Silikondichtung (5 St.) / Joint en silicone / Junta en silicona

THEA HYDRO 23 S1

Gruppo ventilazione / Ventilation group / Lüftungsgruppe / Groupe de ventilation / Grupo de ventilación

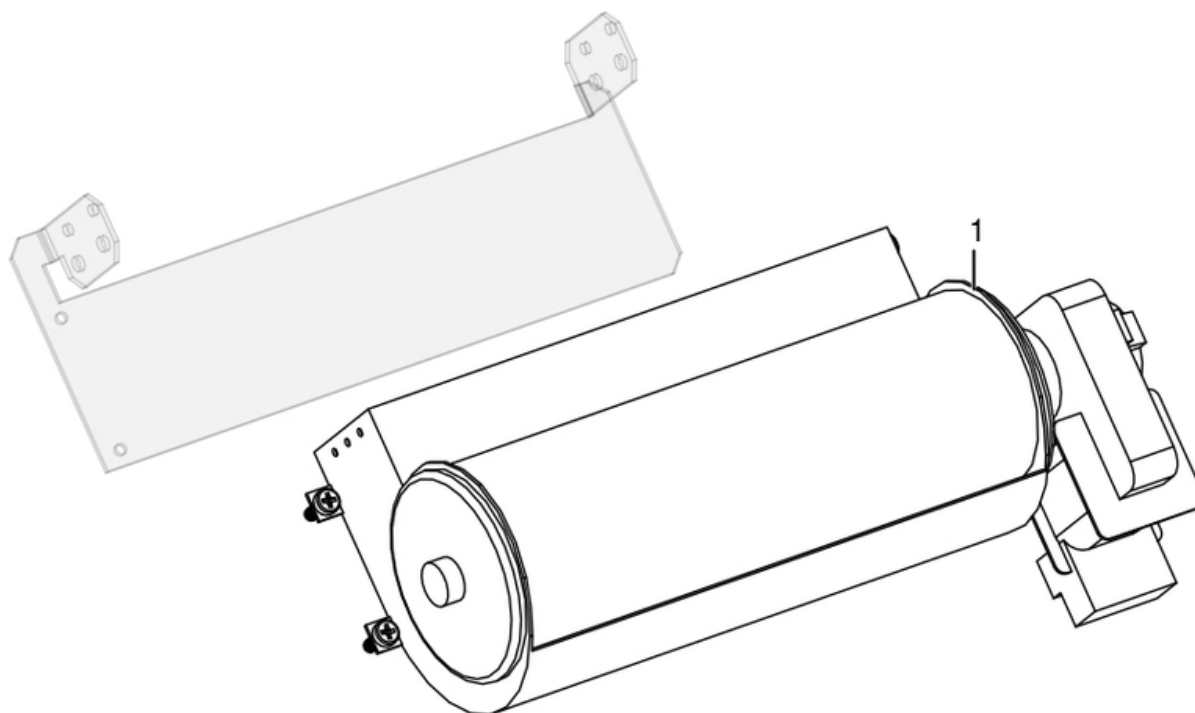

N°	Codice/Code	Descrizioni / Description / Beschreibung / Description / Descripción
1	41451000300	Ventilatore scambiatore aria calda / Hot air exchanger fan / Wärmeluftgebläse / Ventilateur échangeur air chaud / Ventilador intercambiador aire caliente

THEA HYDRO 23 S1

Gruppo componenti idraulici / Hydraulic components group / Hydraulische Komponenten / Groupe de composants hydrauliques / Grupo de componentes hidráulicos

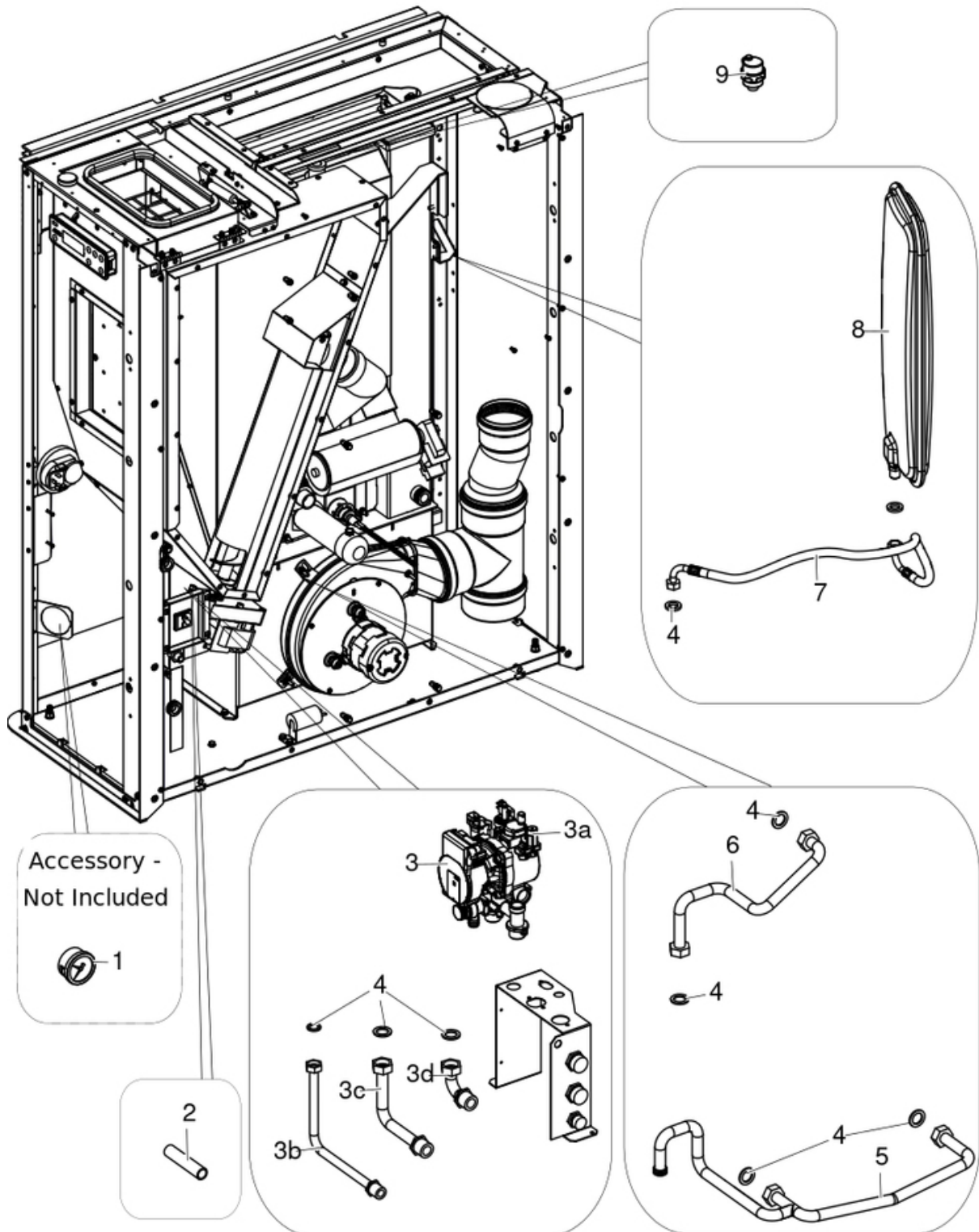

Accessory -
Not Included

N°	Codice/Code	Descrizioni / Description / Beschreibung / Description / Descripción
1	4018035	Idrometro / Hydrometer / Hydrometer / Hydromètre / Hidrómetro
2	41802004500	Tubo gomma valvola sicurezza / Safety valve rubber hose / Sicherheitsventil Gummischlauch / Soupape de sécurité tuyau en caoutchouc / Manguera de goma para válvula de seguridad
3	41502000350	Kit idraulico alta efficienza / High efficiency hydraulic unit / Hoch Effizientz Hydraulikeinheit / Unité hydraulique haut rendement / Unidad hidráulica alto rendimiento
3a	41502002100	Circolatore Wilo Para 7 IPWM / Water circulation pump Wilo Para 7 IPWM / Umwälzpumpe Wilo Para 7 IPWM / Pompe de circulation Wilo Para 7 IPWM / Bomba de circulación agua Wilo Para 7 IPWM
3a	41502000200	Valvola by pass / By pass valva / Ventile By Pass / Soupape By Pass / Valvula by pass
3a	41501103300	Valvola di sicurezza 3 Bar / Maximum pressure valve 3 Bar / Sicherheitsventil 3 Bar / Soupape de pression maximale 3 Bar / Válvula máxima presión 3 Bar
3a	41451108000	Pressostato di minima H2O / Pressur switch H2O / Druckwächter H2O / Pressostat H2O / Presostato H2O
3b	41502000400	Raccordo di carico caldaia / Boiler loading connection / Kessel Ladeanschluss / Port de charge de la chaudière / Puerto de carga de la caldera
3c	41502000500	Raccordo ritorno impianto / System return connection / System Rücklauf Verbindung / Connexion retour système / Conexión de retorno del sistema
3d	41502000600	Raccordo mandata impianto / Delivery tube connection / Vorlaufrohr Verbindung / Raccord tuyau refoulement / Raccor tubo de envío
4	41207910	Kit guarnizioni impianto idraulico / Hydraulic system gasket kit / Dichtungsbausatz für Hydraulikanlage / Kit de joints pour l'installation hydraulique / Kit de juntas de la instalación de fontanería
5	41502000800	Tubo circolatore caldaia / Boiler circulator tube / Kessel Zirkulatorrohr / Tube de circulation de chaudière / Tubo circulador de caldera
6	41502000700	Raccordo tubo mandata impianto / Delivery tube connection / Vorlaufrohr Verbindung / Raccord tuyau refoulement / Raccor tubo de envío
7	41501100800	Tubo di mandata acqua da caldaia / Boiler water delivery tube / Vorlaufrohr Wasser vom Kessel / Tuyau de refoulement eau de la chaudière / Tubo de envío de agua de la caldera
8	4120775	Vaso espansione (6 l) / Expansion vessel (6 l) / Expansionsgefäß (6 l) / Vase d'expansion (6 l) / Vaso de expansión (6 l)
9	4120779	Valvola di sfiato / Vent valve / Entlüftungsventil / Soupape de dégagement / Válvula respiradero

THEA HYDRO 23 S1

Gruppo scambiatore / Exchanger group / Austausch Baugruppe / Groupe échangeur / Grupo intercambiador

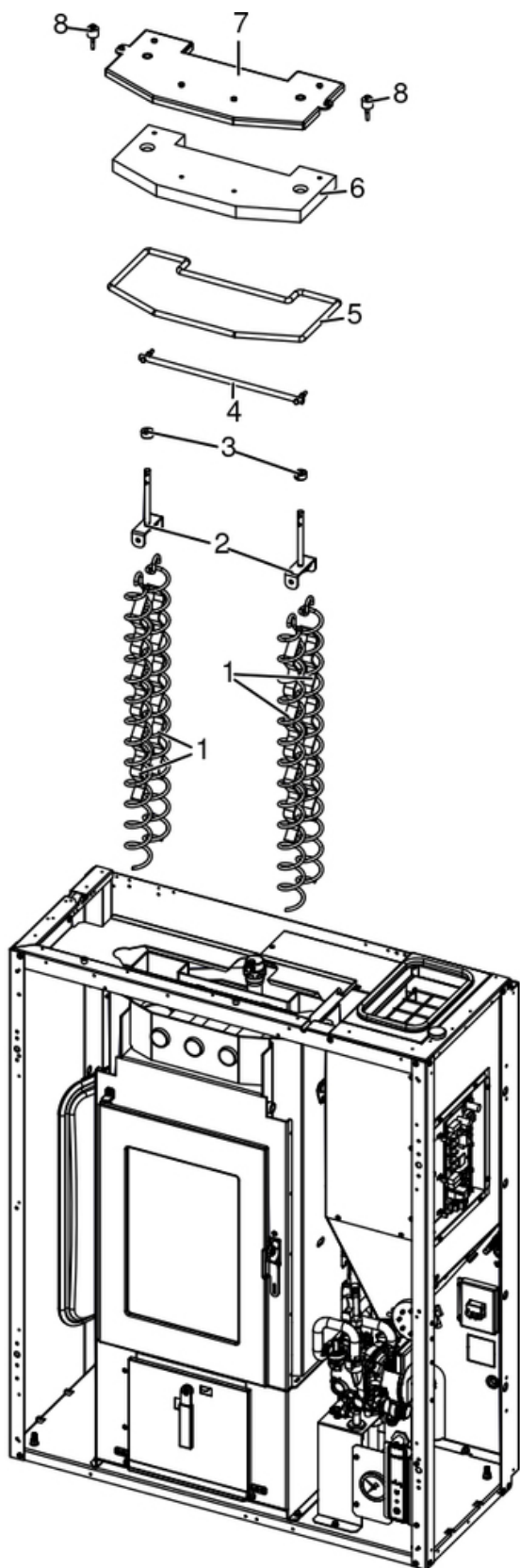

N°	Codice/Code	Descrizioni / Description / Beschreibung / Description / Descripcion
1	41400914540	Eliche raschiatore (1 pz.) / Turbulator props (1 pc.) / Propeller des Schabers (1 Teil) / Hélices turbulateur (1 pz.) / Hélice rascador (1 pz.)
2	41401129341	Staffa sostegno raschiatore Inox / Inox turbulator support bar / Haltebügel des Schabers aus Inox / Etrier support turbulateur en Inox / Zuncho apoyo rascador de Inox
3	41200903300	Trascinatore turbolatori (2 pz.) / Turbolator props puller (2 PC.) / Reinigungsspiralenmitnehmer (2 STCK). / Meneur de turbolateur (2 Pc.) / Arrebatador hélice rascador (2 pz.)
4	41201801360	Leva movimento turbolatori esterni / External turbulator movement lever / Aussere Turbulatorbewegungshebel / Levier de mouvement du turbulateur externe / Palanca de movimiento del turbulador externo
5	41801603200A	Treccia Ø10(5mt) / Braid Ø10(5mt) / Zopf Ø10(5mt) / Tresse Ø10(5mt) / Trenza Ø10(5mt)
6	41151600100	Pannello vermiculite coperchio / Vermiculite cover / Deckel aus Vermiculite / Couvercle en vermiculite / Tapa en vermiculite
7	41411608940V	Coperchio struttura caldaia nero / Boiler black cover / Schwarz Kelleldeckel / Couvercle noir chaudière / Tapa negra caldera
8	41801499550	Kit scarico sovrappressione camera di combustione (pz.2) / Pressure relief kit (Pcs.2) / Bausatz überdruckablauf brennkammer (Stck.2) / Kit decompression chambre combustion (Pcs.2) / Kit descompresion camara combustion (Pcs.2)