

VIVO 90 HYDRO 24 M1

Gruppo struttura mobile / Movable structure group / Bewegliche Struktur Gruppe / Group structure mobile / Grupo estructura móvil

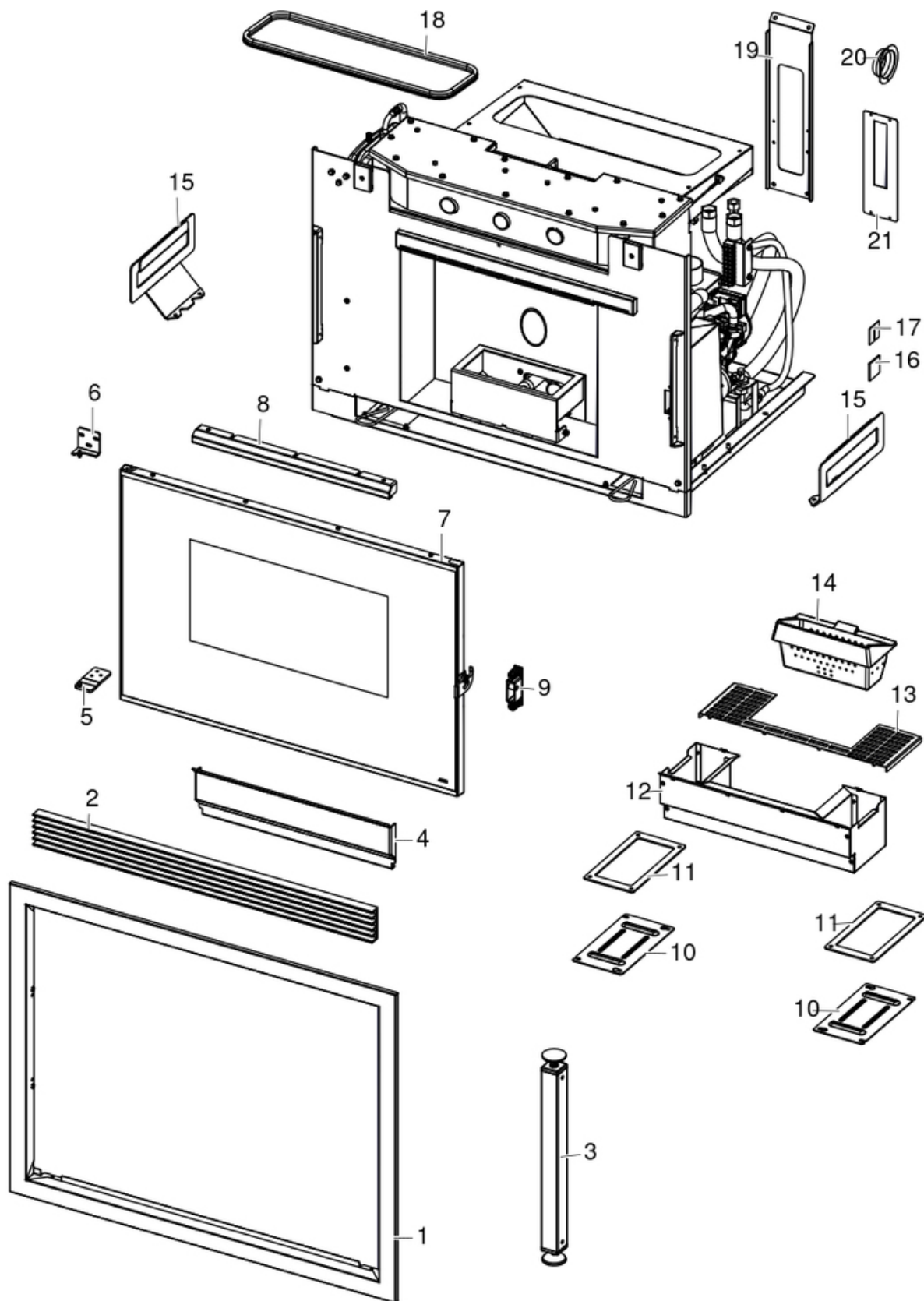

N°	Codice/Code	Descrizioni / Description / Beschreibung / Description / Descripción
1	4140205314000	Cornice / Frame / Rahmen / Cadre / Armazón
2	4131200040000	Griglia frontale / Front grille / Vordere Gitter / Grille frontale / Rejilla frontal
3	41402111750	Supporto per estrazione / Extraction support / Halterung für Herausziehen / Support pour l'extraction / Soporte extracción
4	4140204843000	Paratia focolare / Fireplace bulkhead / Trennwand des Feuerraums / Cloison du foyer / Mamparo de Hogar
5	4140204714000	Cerniera inferiore nera / Black lower hinge / Schwarzes unteres Scharnier / Charnière inférieure noire / Bisagra inferior negra
6	4140204904000	Cerniera superiore / Upper hinge / Oberes Scharnier / Charnière supérieure / Bisagra superior
7	41402079250	Porta ghisa completa / Cast iron complete door / Komplette Tür aus Güsseisen / Porte en fonte complète / Puerta completa de arrabio
8	4140205373100	Deflettore aria vetro / Door deflector / Leitblech der Tür / Déflecteur de la porte / Deflector de la puerta
9	41411599950	Kit serratura ammortizzato / Pressur relief kit / Bausatz Überdruckablauf Brennkammer / Kit decompression chambre comcusion / Kit decompression cámara combustion
10	41401339610	Tappo ispezione vano fumi / Smoke compartment inspection plug / Inspektionsdeckel Rauchabzug / Clapet inspection compartiment fumées / Tapón inspección compartimento humos
10	41800900600	Guarnizione / Gasket / Dichtung / Joint / Junta
11	41801599750	Kit 50 guarnizioni / Kit 50 gaskets / Bausatz 50 Dichtungen / Kit 50 joints / Kit 50 juntas
12	41402054650	Cassetto cenere / Ash drawer / Aschenkasten / Tiroir à cendres / Cajón ceniza
13	4140204883000	Griglia cassetto cenere / Ash drawer grille / Aschenkastengitter / Grille tiroir à cendres / Rejilla cajón ceniza
14	4130200480000	Braciere ghisa / Cast iron brazier / Brennschale aus Guß / Brasero en fonte / Brasero de arrabio
15	4018032	Kit maniglie / Handles kit / Kit von Griffe / Kit de poignées / Kit tirador
16	41802005700	Guarnizione placca aria / Air plate gasket / Luftplattendichtung / Joint de plaque à air / Junta de placa de aire
17	41402074210	Placca d'aria per il vetro / Glass air plate / Luftplatte für Glas / Plaque à air pour verre / Placa de aire para vidrio
18	41801208000	Guarnizione - 5 m / Gasket - 5 m / Dichtung - 5 m / Joint - 5 m / Junta - 5 m
18	41801208001	Guarnizione - 50 m / Gasket - 50 m / Dichtung - 50 m / Joint - 50 m / Junta - 50 m
18	41801208002	Guarnizione - 2,5 m / Gasket - 2,5 m / Dichtung - 2,5 m / Joint - 2,5 m / Junta - 2,5 m
19	41402051130	Supporto serbatoio / Tank support / Tank Haltebügel / Support de réservoir / Soporte de depósito pellet
20	4011011	Flangia Ø 6 / Flange Ø 6 / Flansch Ø 6 / Bride Ø 6 / Brida Ø 6
21	4140211141000	Piastra supporto pannello d'emergenza / Support for the emergency display / Halterung der Notfall-Blende / Support du panneau d'urgence / Placa de soporte del panel de emergencia

VIVO 90 HYDRO 24 M1

Porta fuoco / Fire door / Feuertür / Porte foyer / Puerta hogar

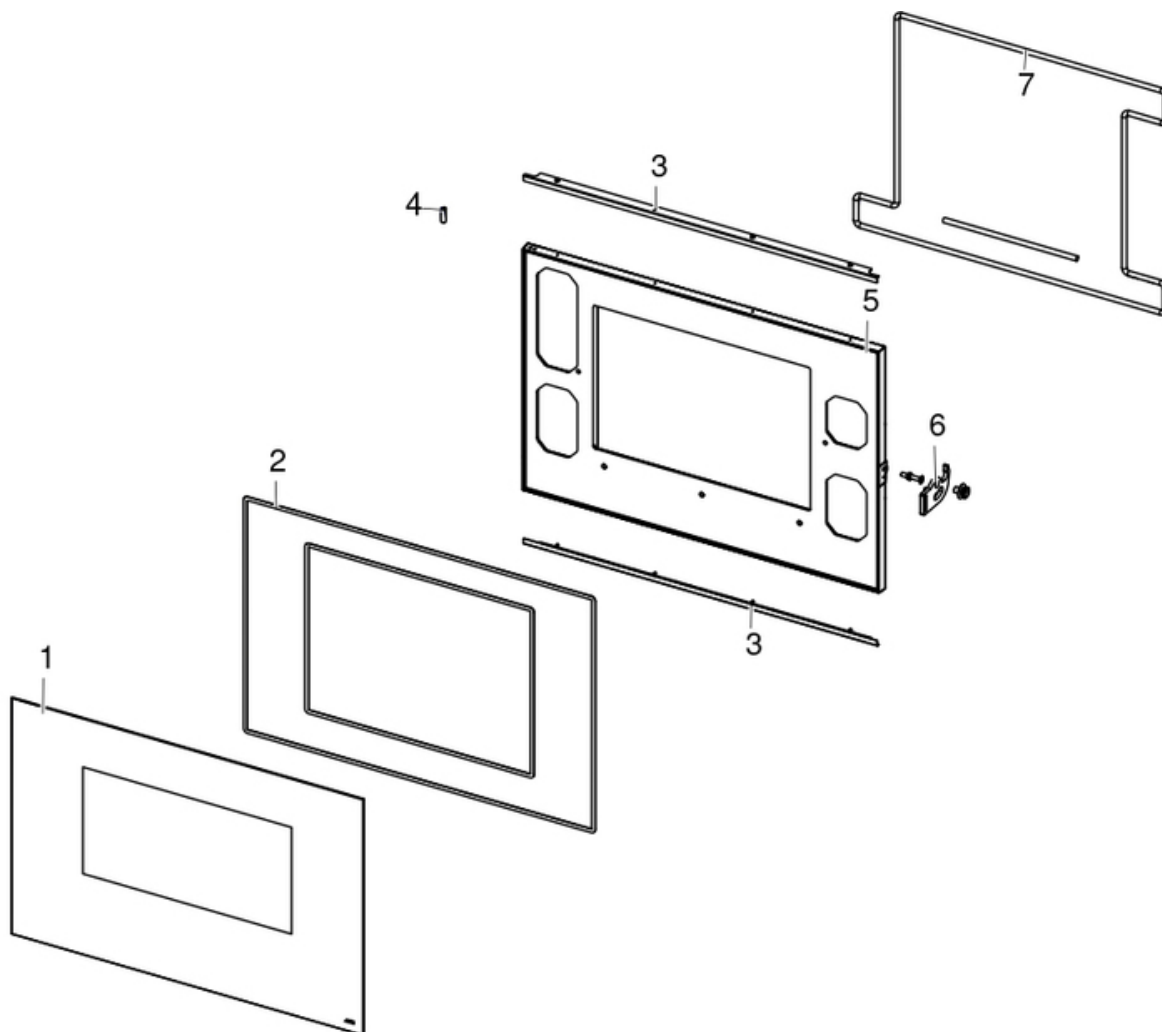

N°	Codice/Code	Descrizioni / Description / Beschreibung / Description / Descripción
1	41702000192	Vetroceramico / Glass / Glaskeramikscheibe / Vitrocéramique / Cristal cerámico
2	4120573A	Guarnizione a nastro 8 mm (5 mt.) per porta / Door strip gasket 8 mm (5 m) / Türbanddichtung 8 mm (5 m) / Joint ruban 8 mm (5 m) pour porte / Guarnición de cinta para puerta 8 mm (5 m)
2	4120573B	Guarnizione a nastro 8 mm (50 mt.) per porta / Door strip gasket 8 mm (50 m) / Türbanddichtung 8 mm (50 m) / Joint ruban 8 mm (50 m) pour porte / Guarnición de cinta para puerta 8 mm (50 m)
3	4140213403000	Fermavetro porta (2 pz) / Glass fastening bracket door (2 pcs) / Haltebügel für Scheibebefestigung Tür (2 Stck) / Etrier de fixation vitrocéramique - porte (2 pc) / Retendor del cristal - Puerta (2 pz)
4	412008062	Cerniere porta fuoco / Fire door hinges / Scharniere Feuertür / Charnières porte foyer / bisagras puerta del hogar
5	4130200490200	Porta ghisa / Cast iron door / Tür aus Güsseisen / Porte en fonte / Puerta de arrabio
6	41411840660	Maniglia / Handle / Türgriff / Poignée / Tirador puerta
7	41802003000	Treccia Ø 12 / Braid Ø 12 / Dichtung Ø 12 / Tresse Ø 12 / Trenza Ø 12

VIVO 90 HYDRO 24 M1

Gruppo caricamento pellet / Pellet feed group / Pellet Fördergruppe / Groupe chargement du pellet / Grupo de carga pellet

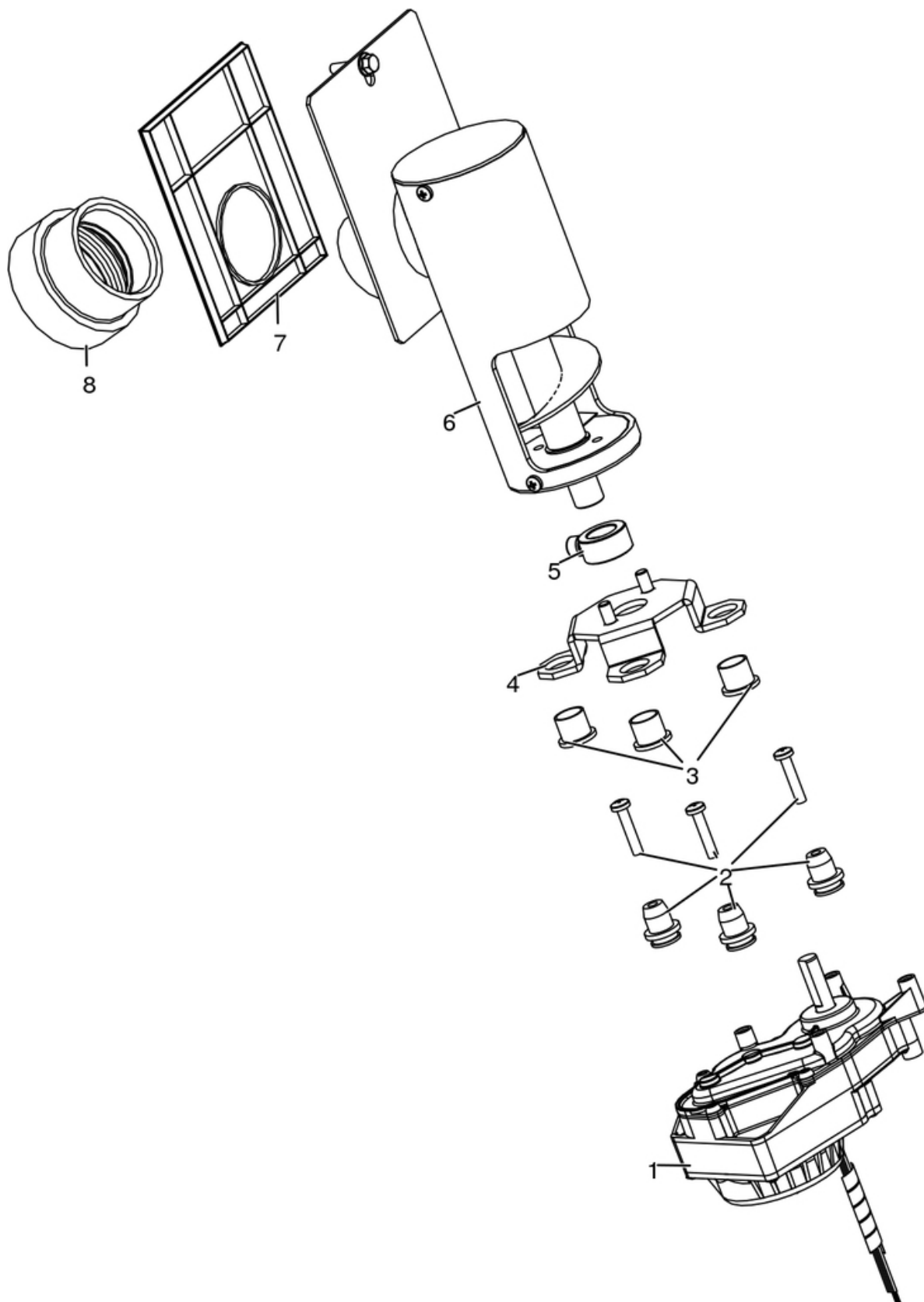

N°	Codice/Code	Descrizioni / Description / Beschreibung / Description / Descripción
1	41451702200	Motoriduttore brushless / Brushless reduction motor / Brushless Getriebemotor / Motoréducteur brushless / Motorreductor brushless
2	41801703700	Gommini antivibrante / Vibration damper rubber / Rammschutz Gummi / Caoutchouc antivibratoire / Cauchitos antivibración
3	41201800700	Boccola (3 pz) / Bushing (3 pcs) / Buchse (3 Stk) / Douille (3 pcs) / Abrazadera (3 pzs)
4	41411779331	Supporto coclea "Ragno" / Pellet feed screw bracket "spider" / "Spinne" Schenke Gestell / Support vis sans fin "Araignée" / Soporte coclea "Araña"
5	4120398	Connettore motoriduttore-coclea / Reduction motor-feed screw connector / Verbindung Getriebemotor-Schnecke / Connecteur motoréducteur-vis sans fin / Conector motorreductor-cóclea
6	437018060	Coclea caricamento pellet / Pellet feed screw / Pelletsförderschnecke / Vis Sans Fin Pour Chargement Pellet / Còclea De Carga Pellet
6	41411926940	Coclea caricamento pellet / Pellet feed screw / Pelletsförderschnecke / Vis Sans Fin Pour Chargement Pellet / Còclea De Carga Pellet
7	41801600400	Guarnizione gruppo caricamento / Gasket / Dichtung / Joint / Junta
8	41801702600	Disaccoppiatore mesc. Marrone / Brown disengaging device / Braun Verängungsrohr / Tuyau de découplage maron / Tubo de desvío marron

VIVO 90 HYDRO 24 M1

Sportello di caricamento pellet / Pellet loading door / Klappe Pelleteinfüllung / Porte de chargement des granulés de bois / Puerta de carga de los pellets de madera

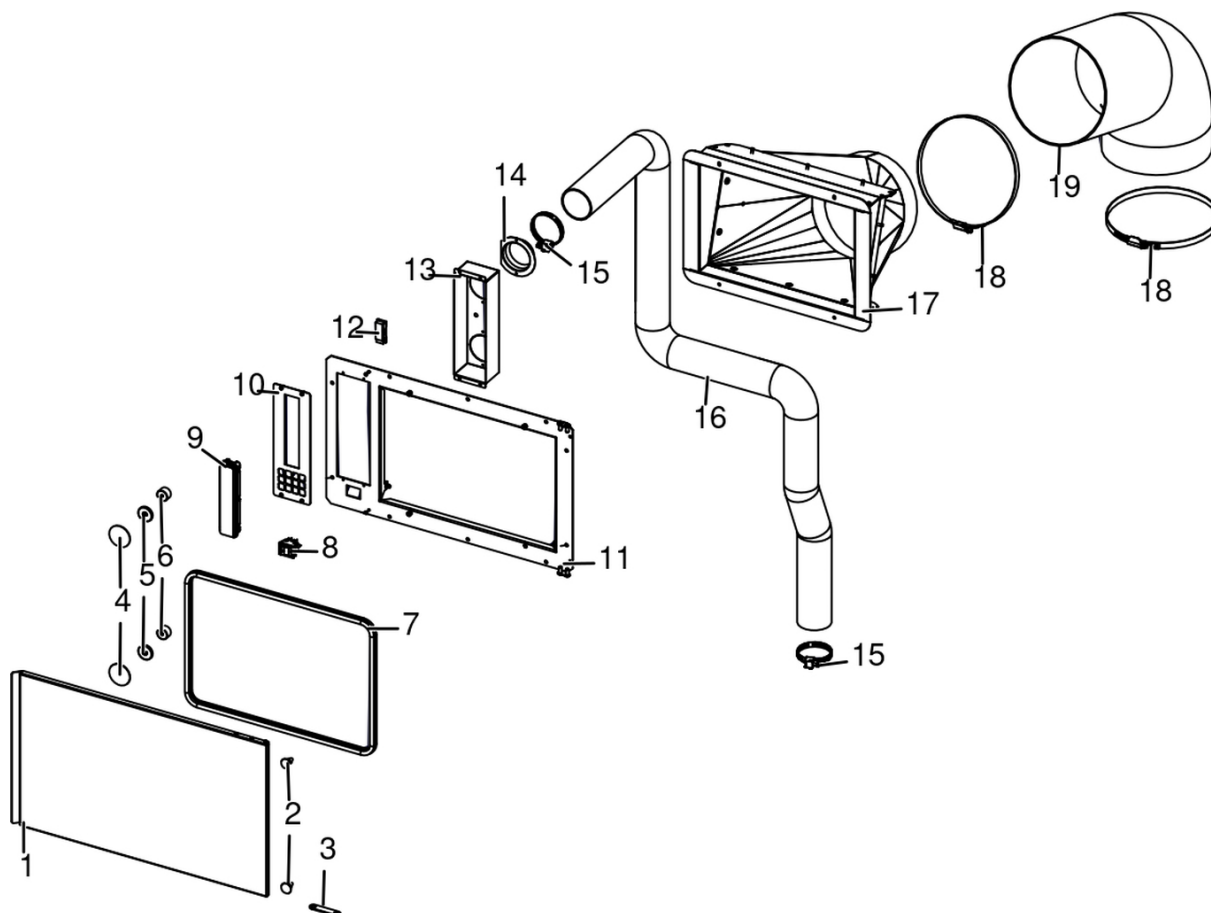

N°	Codice/Code	Descrizioni / Description / Beschreibung / Description / Descripcion
1	4141194233000	Sportello caricamento pellet / Pellet loading door / Klappe Pelleteinfüllung / Porte de chargement pellet / Puerta de carga pellet
2	41801002300	Paracolpi in silicone Ø 8/5 (2pz) / Silicone bumpers Ø 8/5 (2pcs) / Schlagschutzgummi Ø 8/5 (2 Stck) / Pièces silicone antichoc Ø 8/5 (2pcs) / Anti-golpes en silicona Ø 8/5 (2pzs)
3	41401911310	Fermo sportello / Door locker / Türfesthalter / Fermeture pour porte / Bloque por puerta
4	41801807000	Feltrino Ø30x1 (50 pz) / Feltre Ø30x1 (50 pc) / Filz Ø30x1 (50 St) / Feltre Ø30x1 (50 pc) / Feltre Ø30x1 (50 pz)
5	41801657900	Magneti (pz.2) / Magnet (pcs.2) / Magnet (stk. 2) / Aimant (pcs.2) / Imán (pz.2)
6	41201803400	Distanziale magnete / Magnet spacer / Magnet Abstandsstück / Espaceur aimant / Separador magneto
7	41801208000	Guarnizione - 5 m / Gasket - 5 m / Dichtung - 5 m / Joint - 5 m / Junta - 5 m
7	41801208001	Guarnizione - 50 m / Gasket - 50 m / Dichtung - 50 m / Joint - 50 m / Junta - 50 m
7	41801208002	Guarnizione - 2,5 m / Gasket - 2,5 m / Dichtung - 2,5 m / Joint - 2,5 m / Junta - 2,5 m
8	41450905500	Pulsante accensione / On/Off button / Zündungstaste / Touche d'allumage / Botón encendido
9	41451602802	Pannello di emergenza Wireless / Wireless emergency display / Wireless Notfall-Blende / Panneau d'urgence wireless / Panel emergencia wireless
10	4141194261100	Supporto pannello comandi / Display support / Halterung Notfalldisplay / Support panneau de controle / Soporte panel de mandos
11	4141194253000	Supporto caricatore / Pellet loading door support / Halterung Klappe Pelleteinfüllung / Support porte de chargement pellet / Soporte puerta de carga pellet
12	41801501400	Fermacavo (5 pz) / Cable fastening bracket (5 pc) / Kabel Halterung (5 St) / Patte de fixation cable (5 pc) / Retendor cable (5 pz)
13	4141194243000	Scatola pannello emergenza / Emergency display box / Kasten Notfalldisplay / Boîte panneau d'urgence / Caja panel de mandos
14	4011011	Flangia Ø 6 / Flange Ø 6 / Flansch Ø 6 / Bride Ø 6 / Brida Ø 6

15	41200902000	Fascette Ø 64-76 mm (2 pz) / Clamps Ø 64-76 mm (2 pcs) / Rohrschellen Ø 64-76 mm (2 Stck) / Colliers Ø 64-76 mm (2 pcs) / Bandas Ø 64-76 mm (2 pzs)
16	41801201100	Tubo aspirazione aria comburente / Combustion air aspiration tube / Verbrennungsluft Förderrohr / Tuyau aspiration air comburant / Tubo aspiración aire de combustión
17	41411942750	Supporto sportello / Loading door support / Klappe Halterung / Support porte de chargement / Soporte puerta de carga
18	41801901000	Fascetta / Cable tie / Kabelbinder / attache de câble / brida
19	418008016	Tubo di caricamento pellet / Pellet loading tube / Rohr für Pelleteinfüllung / Tuyau de chargement des granulés / Tubo de carga pellets

VIVO 90 HYDRO 24 M1

Gruppo accensione / Ignition group / Entzündung Gruppe / Groupe d'allumage / Grupo ignición

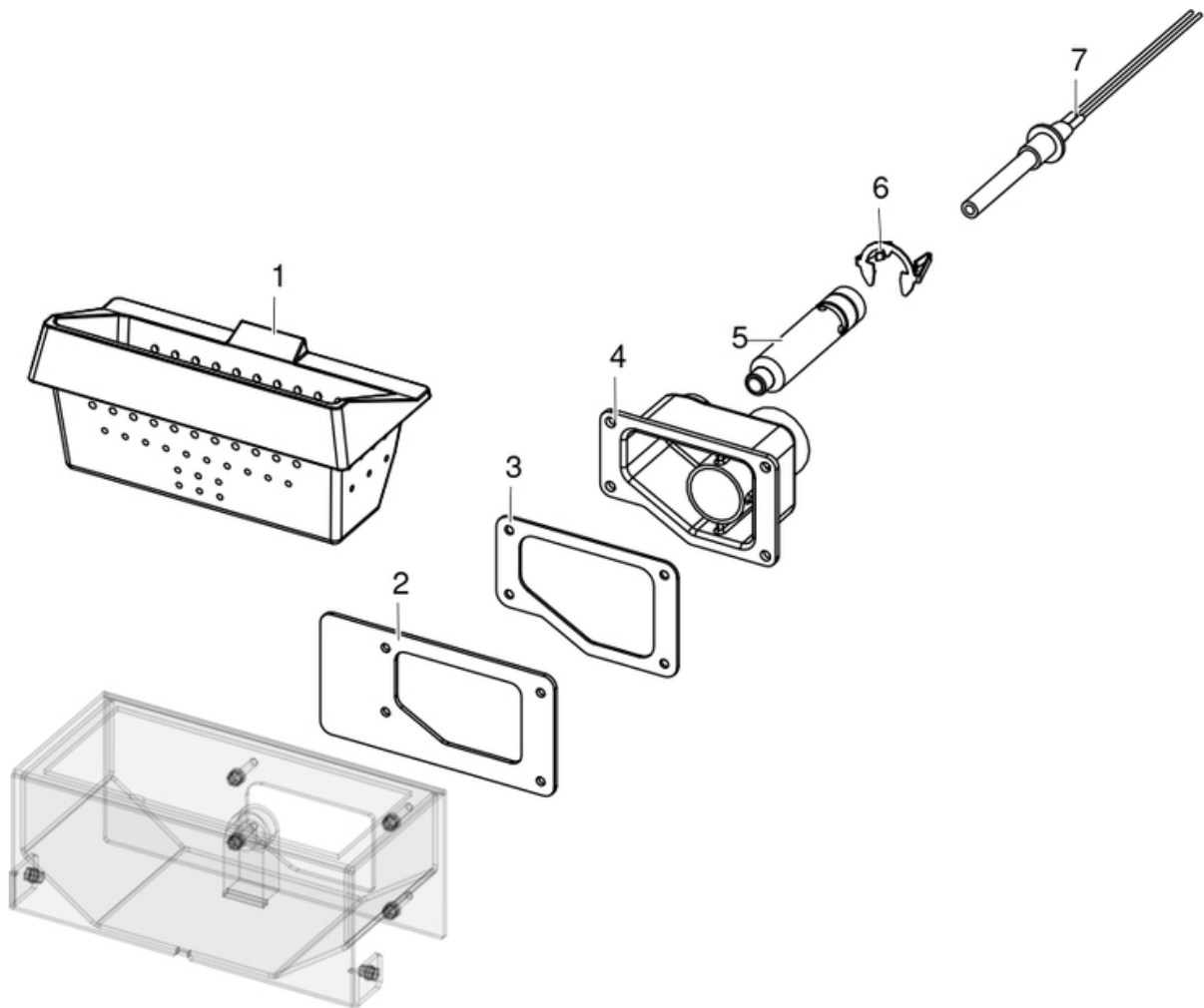

N°	Codice/Code	Descrizioni / Description / Beschreibung / Description / Descripcion
----	-------------	--

1	4130200480000	Braciere ghisa / Cast iron brazier / Brennschale aus Guß / Brasero en fonte / Brasero de arrabio
2	41801601500	Guarnizione tasca braciere / Combustion pot container gasket / Brenntopfkasten Dichtung / Joint récipient brasero / Junta contenidor brasero
3	41801602300	Guarniziona codolo / Gasket / Dichtung / Joint / Junta
4	41311803500	Codolo / Tool chuck / Einspannschaft / Outil d'emmanchement / Mango
5	41601601000	Condotto candeletta / Sparkplug Conduit / Zündkerzenkanal / Conduit Bougie / Conducto Bujía
6	41201601500	Anello arresto candeletta / Sparkplug stop / Zündkerzestopper / Butée bougie / Tope bujía
7	41451308101	Candeletta 315 Watt / Sparkplug 315 Watt / Zündkerze 315 Watt / Bougie 315 Watt / Bujía 315 Watt
7	41451308150	Kit 25 candelette 315 Watt / 25 Sparkplugs 315 Watt kit / Bausatz 25 Zündkerzen 315 Watt / Kit 25 Bougies 315 Watt / Kit 25 Bujías 315 Watt

VIVO 90 HYDRO 24 M1

Gruppo elettrico ed elettronico / Electrical and electronic group / Elektrische und elektronische Gruppe /
Groupe électrique et électronique / Grupo eléctrico y electrónico

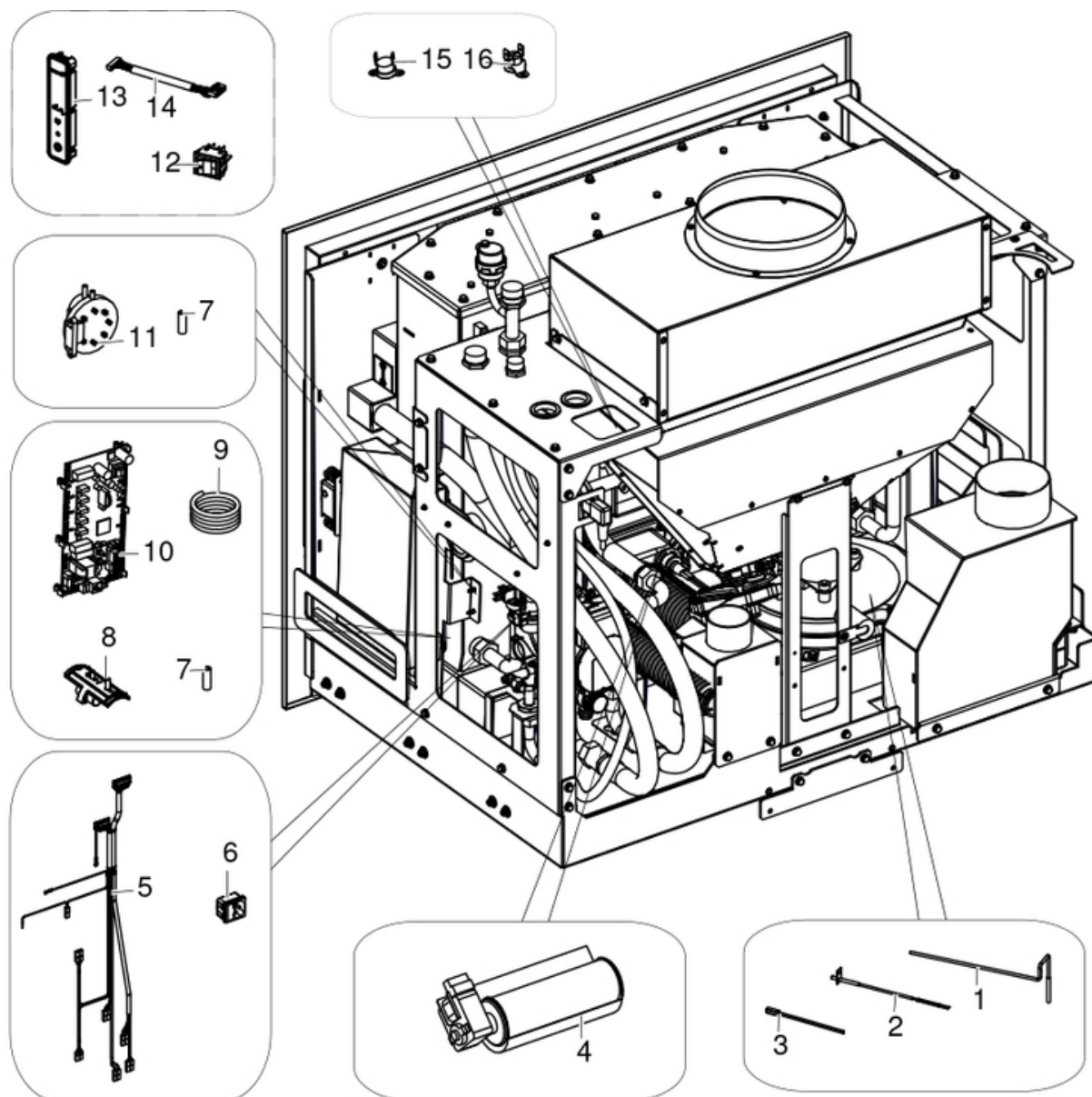

N°	Codice/Code	Descrizioni / Description / Beschreibung / Description / Descripcion
1	4012062	Sonda NTC a filo per acqua / Water temperature sensor / Wassertemperaturfühler / Sonde température eau / Sonda temperatura agua
2	41451703600	Sonda fumi con flangia con morsettiera L.980 / Smoke sensor with flange with terminal board L.980 / Rauchsonde mit Flansche mit Klemmenbrett L.980 / Sonde fumées avec bride avec serre-câble L.980 / Sonda humos con brida con borne L.980
3	4160240	Sonda temperatura ambiente / Room temperature sensor / Raumtemperaturfühler / Sonde température ambiance / Sonda temperatura aire
4	41451800900	Ventilatore tangenziale / Warm air fan / Luftgebläse / Ventilateur air / Ventilador aire
5	41452003601	Cablaggio elettrico / Electrical wiring / Elektrische Verkabelung / Câblage électrique / Cableado eléctrico
6	41451104100	Presa con fusibile / Socket with fuse / Steckdose mit Sicherung / Prise avec fusible / Toma con fisible
7	4120631A	Tubicino siliconico - 5m / Silicon tube - 5m / Silikonrohr - 5m / Petit tuyau en silicone - 5m / Tubo silicónico - 5m
8	41601305050	Componente rilevamento portata aria / Air flow measure component / Bauteil für Messung der Luftmenge / Composant pour la mesuration de la quantité d'air / Componente por la medida de l'aire
9	41801902500	Spirale Rilsan (30 m.) / Rilsan spiral (30 m.) / Spirale Rilsan (30 M.) / Spirale Rilsan (30 m.) / Espiral Rilsan (30 m.)
9	41801902500A	Spirale Rilsan (5 spire) / Rilsan spiral (5 coils) / Spirale Rilsan (5 Windungen) / Spirale Rilsan (5 spires) / Espiral Rilsan (5 espire)
10	41451904300	Scheda madre / Motherboard / Hauptplatine / Carte mère / Tarjeta madre
11	4160482	Pressostato 0,4 mbar / Pressure gauge 0,4 mbar / Druckschalter 0,4 mbar / Pressostat 0,4 mbar / Presostato 0,4 mbar
12	41450905500	Pulsante accensione / On/Off button / Zündungstaste / Touche d'allumage / Botón encendido
13	41451602801	Pannello di emergenza Wireless / Wireless emergency display / Wireless Notfall-Blende / Panneau d'urgence wireless / Panel emergencia wireless
14	41451905400	Cavo flat / Flat cable / Flat Kabel / Câble Flat / Cable Flat
15	41450901100	Clickson 95°C / Clickson 95°C / Clickson 95°C / Clickson 95°C / Clickson 95°C
16	412007004	Clickson 110°C / Clickson 110°C / Clickson 110°C / Clickson 110°C / Clickson 110°C

VIVO 90 HYDRO 24 M1

Gruppo aria comburente / Combustion air group / Verbrennungsluft Gruppe / Groupe air comburant / Grupo aire comburente

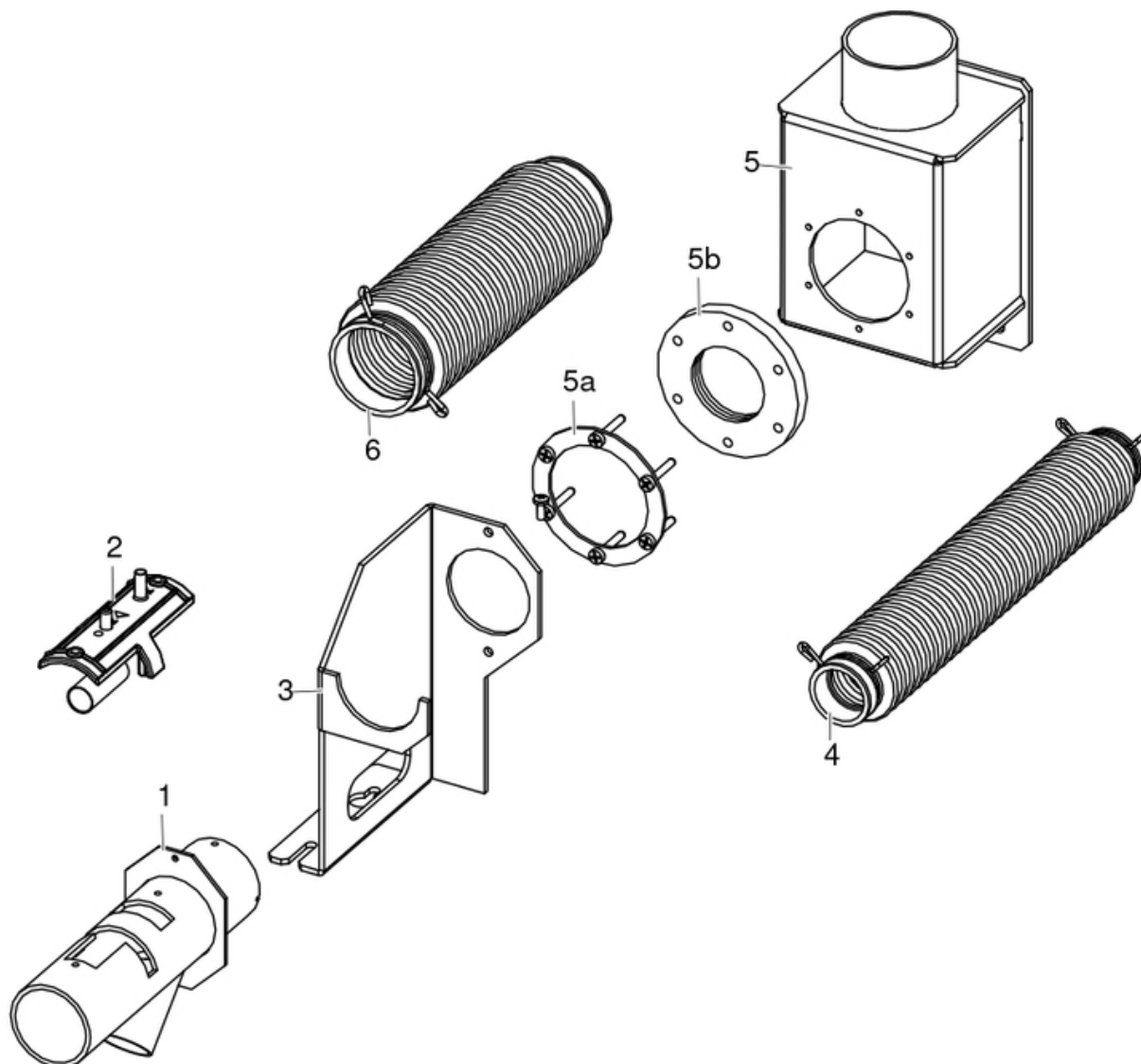

N°	Codice/Code	Descrizioni / Description / Beschreibung / Description / Descripción
1	41601604461	Tubo aspirazione / Air inlet pipe / Lufteingangsrohr / Tuyau entrée d'air / Tubo entrada aire
2	41601305050	Componente rilevamento portata aria / Air flow measure component / Bauteil für Messung der Luftmenge / Composant pour la mesuration de la quantité d'air / Componente por la medida de l'aire
3	41402049331	Supporto tubo aspirazione / Aspiration pipe support / Absaugung Rohr Halterung / Support tuyau aspiration / Soporte tubo aspiración
4	41801601900	Tubo aspirazione pulizia vetro / Inlet pipe for cleaning glass air / Glassreinigungs Lufteingangsrohr / Tuyau entrée pour l'aire de nettoyage du vitre / Tubo entrada por l'aire de limpieza vidrio
5	41411938350	Scatola aria / Air box / Luft Kasten / Boîte de l'air / Caja aire
5a	41401813310	Flangia / Flange / Flansch / Bride / Brida
5b	41801900800	Guarnizione / Gasket / Dichtung / Joint / Junta
6	41801601700	Tubo aspirazione camera combustione / Combustion chamber aspiration tube / Verbrennungskammer Förderrohr / Tuyau aspiration air chambre de combustion / Tubo aspiración aire cámara de combustión

VIVO 90 HYDRO 24 M1

Gruppo fumi / Smoke group / Rauchgruppe / Groupe fumées / Grupo de humos

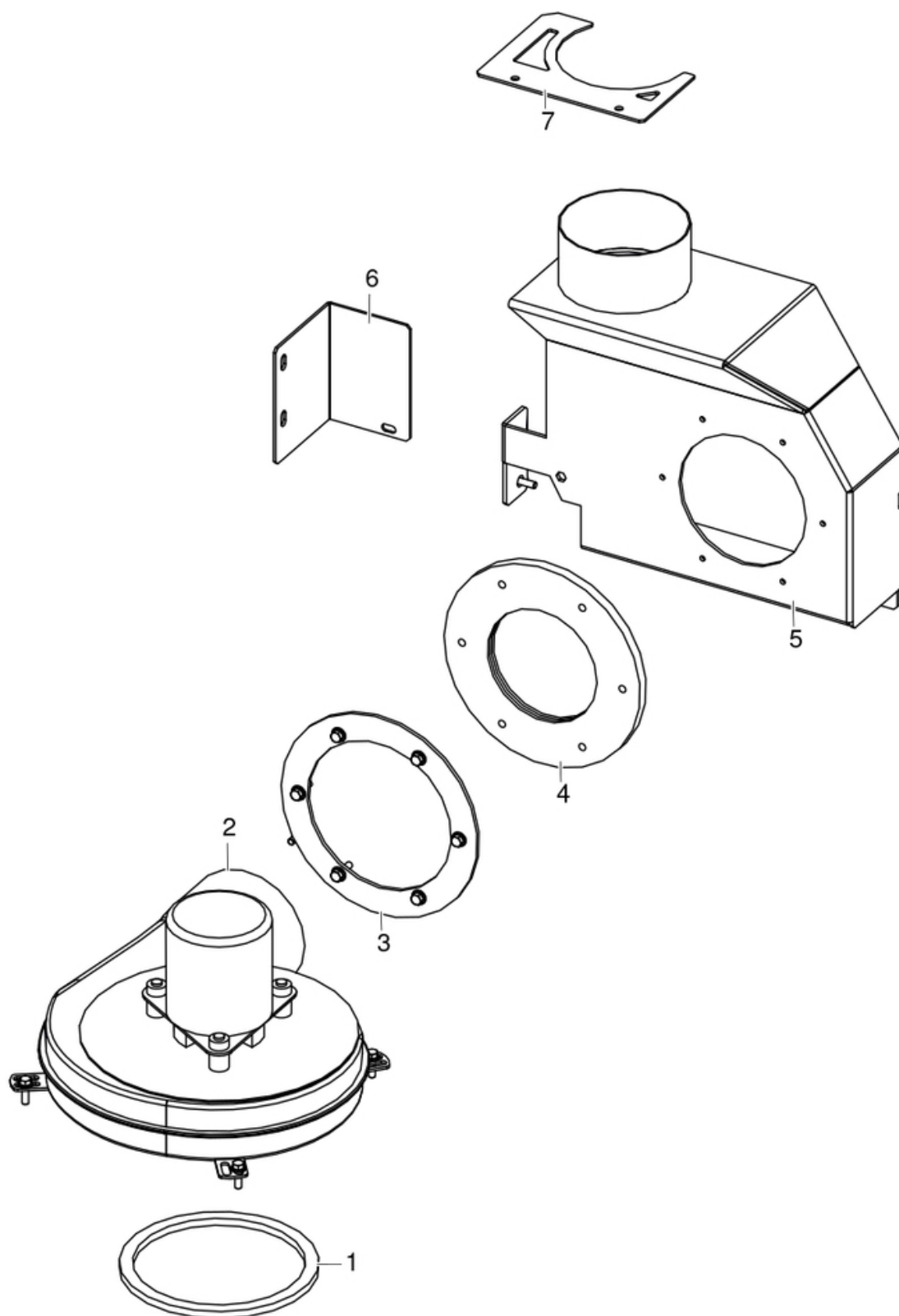

N°	Codice/Code	Descrizioni / Description / Beschreibung / Description / Descripción
1	41801100100	Guarnizione adesiva voluta fumi / Adhesive gasket smoke volute / Haftendichtung Rauchvolute / Joint adhesive volute fumées / Junta adhesiva voluta humos
2	41451201750	Ventilatore fumi / Smoke exhaust fan / Rauchabsauggebläse / Ventilateur aspiration fumées / Ventilador aspiración de humos
3	41402049910	Flangia guarnizione fumi / Smoke gasket flange / Rauch Dichtungsflansch / Bride de joint de fumée / Brida de junta de humo
4	41802001001	Guarnizione fumi / Smoke gasket / Rauchabzug Dichtung / Joint fumées / Junta humos
5	4140204984000	Scatola fumi / Smoke box / Rauchabzug / Boîte à fumée / Caja humos
6	41402050430	Staffa scatola fumi / Smoke box bracket / Bügel der Rauchabzug / Support de boîte à fumée / Soporte Caja Humos
7	41402053210	Staffa tubo fumi / Smoke pipe suport / Haltbügel Rauchrohr / Support tuyau de fumées / Soporte tubo humos

VIVO 90 HYDRO 24 M1

Gruppo scambiatore / Exchanger group / Austausch Baugruppe / Groupe échangeur / Grupo intercambiador

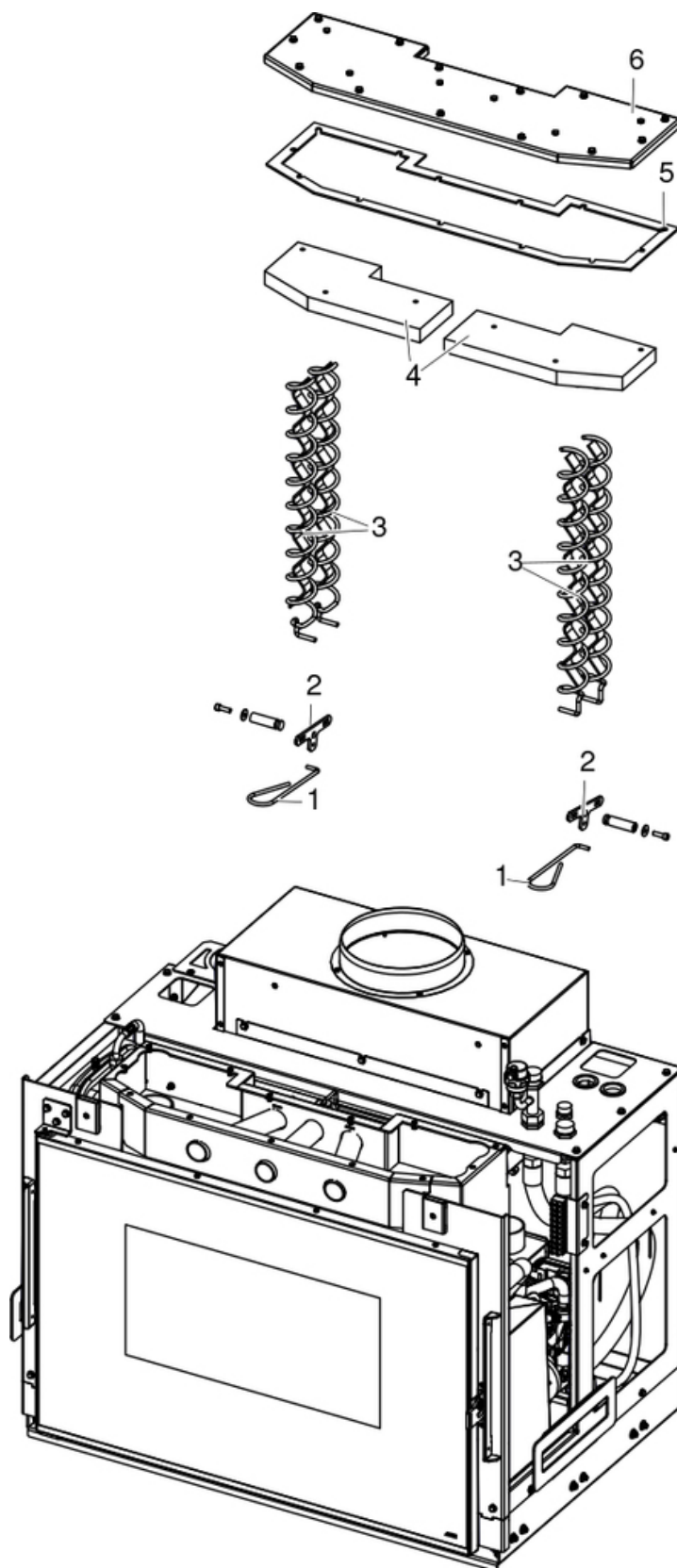

N°	Codice/Code	Descrizioni / Description / Beschreibung / Description / Descripción
1	4120415	Gancio "mano fredda" / "Cool hand" hook / Haken "Kalte Hand" / Crochet "main froide" / Gancho "mano fría"
2	41402047810	Leva movimento turbolatori / Tturbulator movement lever / Turbulatorbewegungshebel / Levier de mouvement du turbulateur / Palanca de movimiento del turbulador
3	41402048040	Turbolatore grezzo / Raw turbulator / Roher Turbulator / Turbulateur brut / Turbulador crudo
4	41152001201	Pannello vermiculite / Vermiculite panel / Paneel aus Vermiculite / Panneau vermiculite / Panel en Vermiculite
5	41802005800	Guarnizione coperchio caldaia / Boiler cover gasket / Kessel Deckeldichtung / Joint de couvercle de chaudière / Junta tapa caldera
6	4140204814000	Coperchio / Cover / Deckel / Couvercle / Tapa

VIVO 90 HYDRO 24 M1

Gruppo componenti idraulici / Hydraulic components group / Hydraulische Komponenten / Groupe de composants hydrauliques / Grupo de componentes hidráulicos

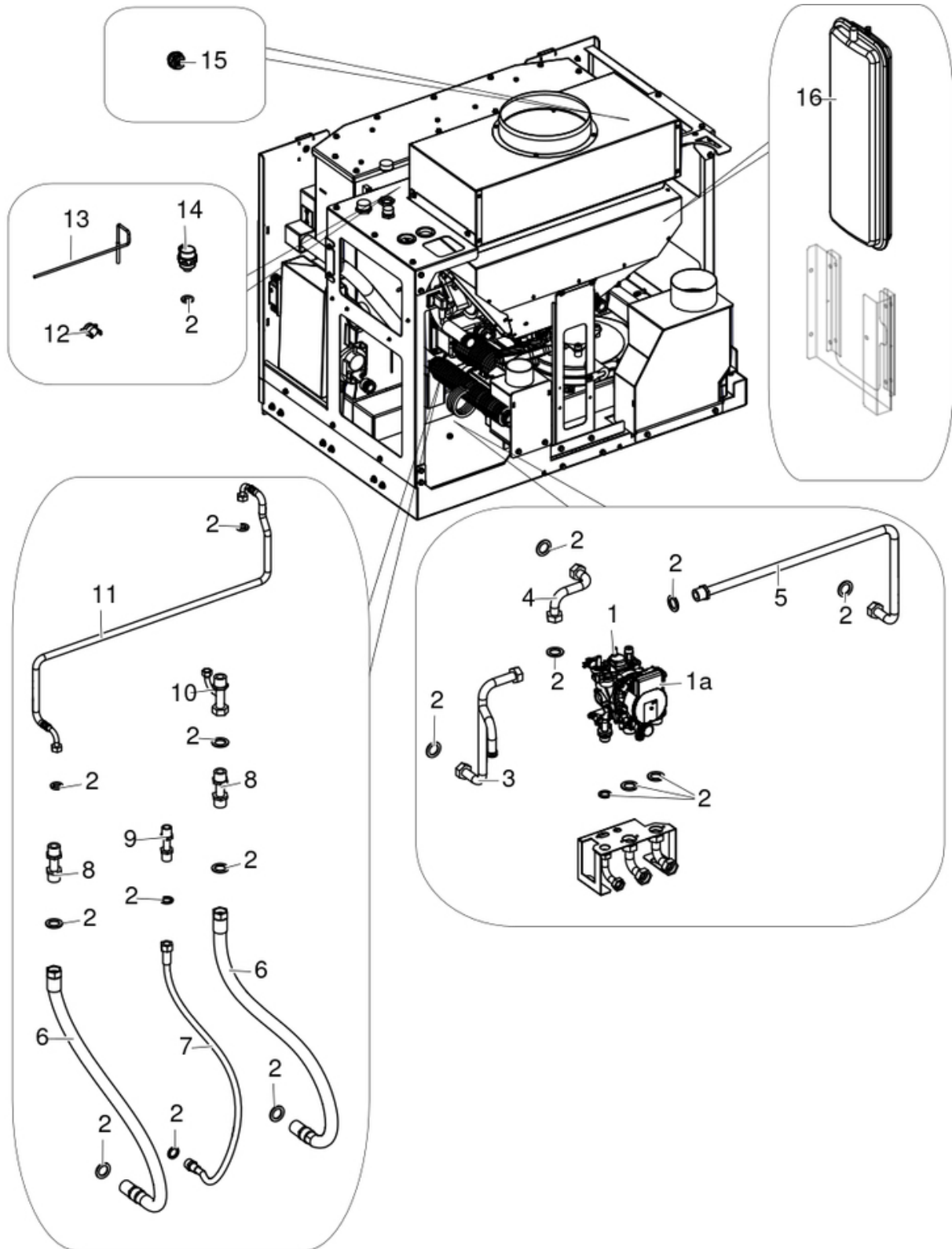

N°	Codice/Code	Descrizioni / Description / Beschreibung / Description / Descripción
1	41502001700	Kit idraulico / Hydraulic kit / Hydraulischer Kit / Kit hydraulique / Unidad hidráulica
1a	41502002100	Circolatore Wilo Para 7 IPWM / Water circulation pump Wilo Para 7 IPWM / Umwälzpumpe Wilo Para 7 IPWM / Pompe de circulation Wilo Para 7 IPWM / Bomba de circulación agua Wilo Para 7 IPWM
1a	41502000200	Valvola by pass / By pass valva / Ventile By Pass / Soupape By Pass / Válvula by pass
1a	41501103300	Valvola di sicurezza 3 Bar / Maximum pressure valve 3 Bar / Sicherheitsventil 3 Bar / Soupape de pression maximale 3 Bar / Válvula máxima presión 3 Bar
1a	41451108000	Pressostato di minima H2O / Pressur switch H2O / Druckwächter H2O / Pressostat H2O / Presostato H2O
2	41207910	Kit guarnizioni impianto idraulico / Hydraulic system gasket kit / Dichtungsbausatz für Hydraulikanlage / Kit de joints pour l'installation hydraulique / Kit de juntas de la instalación de fontanería
3	41502001100	Tubo "A" circolatore caldaia / Boiler circulator tube "A" / Kessel Zirkulatorrohr "A" / Tube de circulation de chaudière "A" / Tubo circulador de caldera "A"
4	41502001300	Tubo mandata impianto / Delivery tube / Vorlaufrohr / Tuyau refoulement / Tubo de envío
5	41502001200	Tubo "B" circolatore caldaia / Boiler circulator tube "B" / Kessel Zirkulatorrohr "B" / Tube de circulation de chaudière "B" / Tubo circulador de caldera "B"
6	41502000100	Tubo flessibile L.800mm / Flexible tube L.800mm / Flexibles Rohr L.800mm / Tuyau flexible L.800mm / Tubo flexible L.800mm
7	41801201600	Tubo flessibile antivibrazioni MF 1/2" L.80CM / Anti-vibration flex-pipe MF 1/2" L.80CM / Schlauch schwingungsdämpfend MF 1/2" L.80CM / Tuyau flexible antivibrations MF 1/2" L.80CM / Tubo flexible antivibraciones MF 1/2" L.80CM
8	41502001400	Tubo raccordo 3/4" / Connecting pipe 3/4" / Verbindungsrohr 3/4" / Tuyau de raccordement 3/4" / Tubería de conexión 3/4"
9	41502001500	Tubo raccordo 1/2" / Connecting pipe 1/2" / Verbindungsrohr 1/2" / Tuyau de raccordement 1/2" / Tubería de conexión 1/2"
10	41502001600	Raccordo valvola sfogo / Relief valve connection / Überdruckventil Anschluss / Connexion de la soupape de décharge / Conexión de la válvula de alivio
11	41501100800	Tubo di mandata acqua da caldaia / Boiler water delivery tube / Vorlaufrohr Wasser vom Kessel / Tuyau de refoulement eau de la chaudière / Tubo de envío de agua de la caldera
12	41450901100	Clickson 95°C / Clickson 95°C / Clickson 95°C / Clickson 95°C / Clickson 95°C
13	4012062	Sonda NTC a filo per acqua / Water temperature sensor / Wassertemperaturfühler / Sonde température eau / Sonda temperatura agua
14	4120779	Valvola di sfiato / Vent valve / Entlüftungsventil / Soupape de dégagement / Válvula respiradero
15	41501200500	Valvola sfiato 3/8" / Vent valve 3/8" / Entlüftungsventil 3/8" / Soupape dégagement 3/8" / Válvula respiradero 3/8"
16	4120775	Vaso espansione (6 l) / Expansion vessel (6 l) / Expansionsgefäß (6 l) / Vase d'expansion (6 l) / Vaso de expansión (6 l)